



MIRAI

Fuel Cell Vehicle

FUEL CELL VEHICLE DISMANTLING MANUAL



Foreword

This guide was developed to educate and assist dismantlers in the safe handling of Toyota MIRAI fuel cell vehicle. MIRAI dismantling procedures are similar to other non-fuel cell Toyota vehicles with the exception of the fuel cell system. It is important to recognize and understand the fuel cell system features and specifications of the Toyota MIRAI fuel cell vehicle, as they may not be familiar to dismantlers.

A fuel cell vehicle efficiently delivers the hydrogen and air (oxygen) necessary for electrical generation to the fuel cell, generates electrical energy, and uses that electrical energy to drive the traction motors that propel the vehicle.

High voltage electricity powers the FC air compressor with motor assembly, compressor with motor assembly, FC converter assembly, FC stack assembly, FC cooling water pump assembly, FCV transaxle with motor assembly, hydrogen recirculation pump assembly, EV supply battery assembly, electric heater sub-assembly, DC/DC converter, voltage inverter assembly and inverter with converter assembly. All other conventional automotive electrical devices such as the head lights, radio, and gauges are powered from a separate 12 Volt auxiliary battery. Numerous safeguards have been designed into the MIRAI to help ensure the high voltage, approximately 310.8 Volt, Lithium-ion (Li-ion) Fuel Cell Vehicle (EV) battery assembly is kept safe and secure in an accident.

The Lithium-ion battery pack contains sealed batteries that are similar to rechargeable batteries used in some battery operated power tools and other consumer products. The electrolyte is absorbed in the cell plates and will not normally leak out even if the battery is cracked. If the electrolyte is leaking, do not touch any leaked liquid because it could be the organic electrolyte that contains carbonate ester-based.

If contact is unavoidable, wipe up the liquid using a cloth while wearing rubber gloves, goggles and an organic solvent mask. Do not leave electrolyte-contaminated cloths unattended. Please contaminated cloths in an appropriate airtight container and dispose of them according to local regulations.

High voltage cables, identifiable by orange insulation and connectors, are isolated from the metal chassis of the vehicle.

Additional topics contained in the guide include:

- Toyota MIRAI identification.
- Major fuel cell vehicle component locations and descriptions.

By following the information in this guide, dismantlers will be able to handle MIRAI fuel cell vehicles as safely as the dismantling of a conventional non-fuel cell automobile.

© 2021 Toyota Motor Corporation

All rights reserved. This book may not be reproduced or copied, in whole or in part, without the written permission of Toyota Motor Corporation.

Table of Contents

<u>Foreword</u>	<u>ii</u>
<u>Table of Contents</u>	<u>iii</u>
<u>About the MIRAI</u>	<u>1</u>
<u>MIRAI Identification</u>	<u>2</u>
<u>Exterior</u>	<u>3</u>
<u>Interior</u>	<u>4</u>
<u>Motor Compartment</u>	<u>5</u>
<u>Fuel Cell Vehicle Component Locations & Descriptions</u>	<u>6</u>
<u>Specifications</u>	<u>8</u>
<u>Fuel Cell Vehicle Operation</u>	<u>9</u>
<u>Vehicle Operation</u>	<u>9</u>
<u>EV Battery and Auxiliary Battery</u>	<u>10</u>
<u>EV Battery</u>	<u>10</u>
<u>Components Powered by the EV Battery</u>	<u>10</u>
<u>EV Battery Recycling</u>	<u>11</u>
<u>Auxiliary Battery</u>	<u>11</u>
<u>Hydrogen Safety</u>	<u>12</u>
<u>About Hydrogen</u>	<u>12</u>
<u>Characteristics of Hydrogen</u>	<u>12</u>
<u>Basic Safety Concepts for Hydrogen System Components</u>	<u>13</u>
<u>High Voltage Safety</u>	<u>14</u>
<u>High Voltage Safety System</u>	<u>14</u>
<u>Service Plug Grip</u>	<u>15</u>
<u>Precaution to be observed when dismantling the vehicle</u>	<u>16</u>
<u>Necessary Items</u>	<u>16</u>
<u>Spills</u>	<u>17</u>
<u>Dismantling the vehicle</u>	<u>18</u>
<u>How to Proceed with Work</u>	<u>18</u>
<u>Discharge Hydrogen Gas from Medium Pressure Port</u>	<u>19</u>
<u>Determine Discharging Method</u>	<u>69</u>
<u>Forced Electrical Charge Discharge Work</u>	<u>73</u>
<u>Removal of EV Battery</u>	<u>77</u>
<u>Removal of Hydrogen Tank</u>	<u>115</u>
<u>Dispose of Hydrogen Tank Assembly</u>	<u>154</u>
<u>Removal of FC Converter with FC Stack Assembly</u>	<u>161</u>
<u>Perform Electrical Charge Self-discharge</u>	<u>225</u>
<u>Removal of FC Stack Assembly</u>	<u>231</u>

About the MIRAI

The MIRAI 4-door sedan is the first fuel cell for Toyota. The Toyota FC System (TFCS) which combines hybrid technology with fuel cell technology such as the Toyota FC stack and high pressure hydrogen tank.

In the fuel cell vehicle, the electric power from the FC stack assembly and EV battery are distributed in an optimal way according to a variety of driving conditions, realizing excellent vehicle performance including smooth starting and acceleration. also, during deceleration the traction motor operates as a regenerative brake to convert braking force into electrical energy that is used for charging the EV battery or powering FC related auxiliary components such as the FC air compressor with motor assembly.

The following illustration demonstrates how the MIRAI operates in various driving modes.

- 1 Under normal conditions, when the vehicle starts to move, the traction motors are powered by electrical energy from the EV battery.
- 2 During steady driving, electrical energy from the FC stack assembly is used to drive the traction motor.
- 3 During acceleration, the electrical power from the FC stack assembly is increased, the boost ratio of the FC converter assembly is made larger, and additional electrical energy is supplied from the EV battery to accelerate the vehicle.
- 4 By using the driving force transmitted through the wheel to spin the traction motor, kinetic energy is converted to electrical energy and used to charge the EV battery, or used by FC auxiliary equipment such as the FC air compressor with motor assembly.
- 5 When the vehicle is stopped and the SOC is low, the FC stack assembly will generate electricity and charge the EV battery.

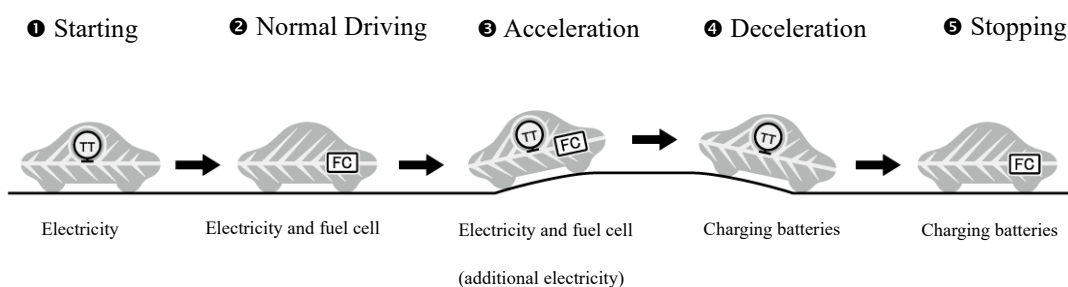

MIRAI Identification

The MIRAI is a 4-door sedan. Exterior, interior, and engine compartment illustrations are provided to assist in identification.

The alphanumeric 15 character Vehicle Identification Number (VIN) is provided in the front windshield cowl, under the right side front seat, and on the left side B pillar.

Example VIN: JTDAAAAA0000101

A MIRAI is identified by the first 8 alphanumeric characters **JTDAAAAA** or **JTDAAABAA**.

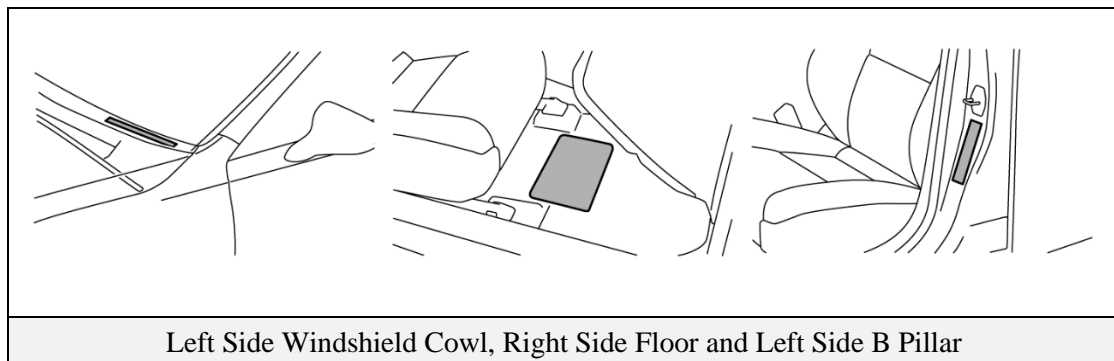

Exterior

- ❶ FUELCELLD logos on the trunk and each rocker panel moulding.
- ❷ Hydrogen fuel filler door located on left side rear quarter panel.

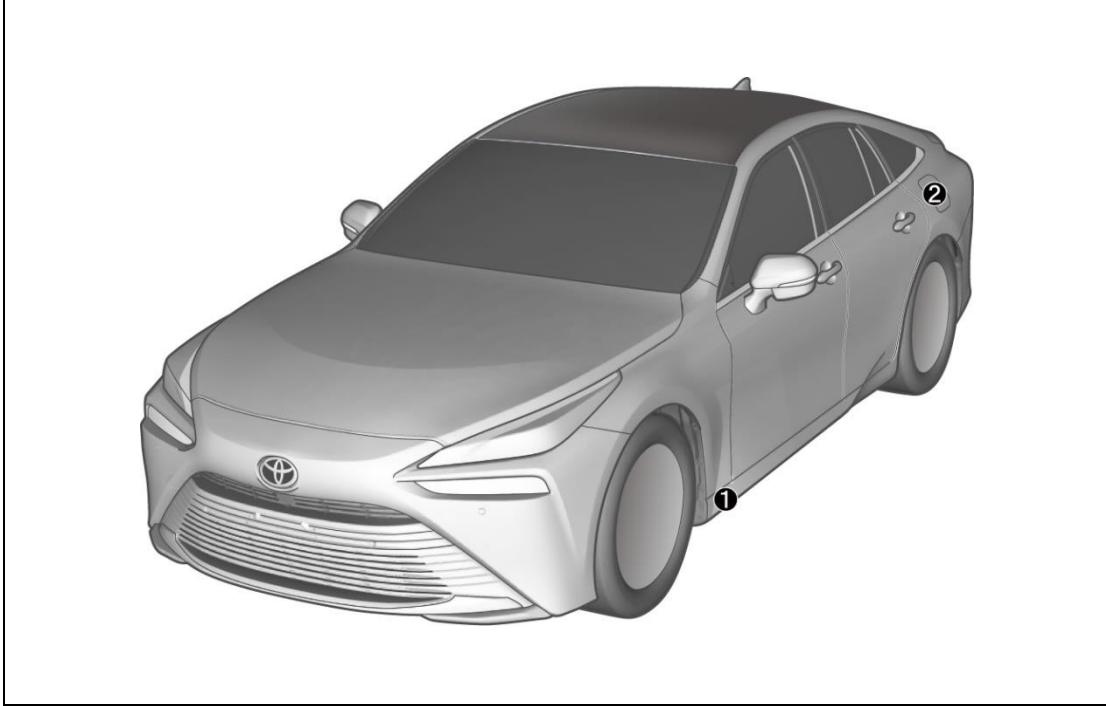

Exterior Front and Left Side View

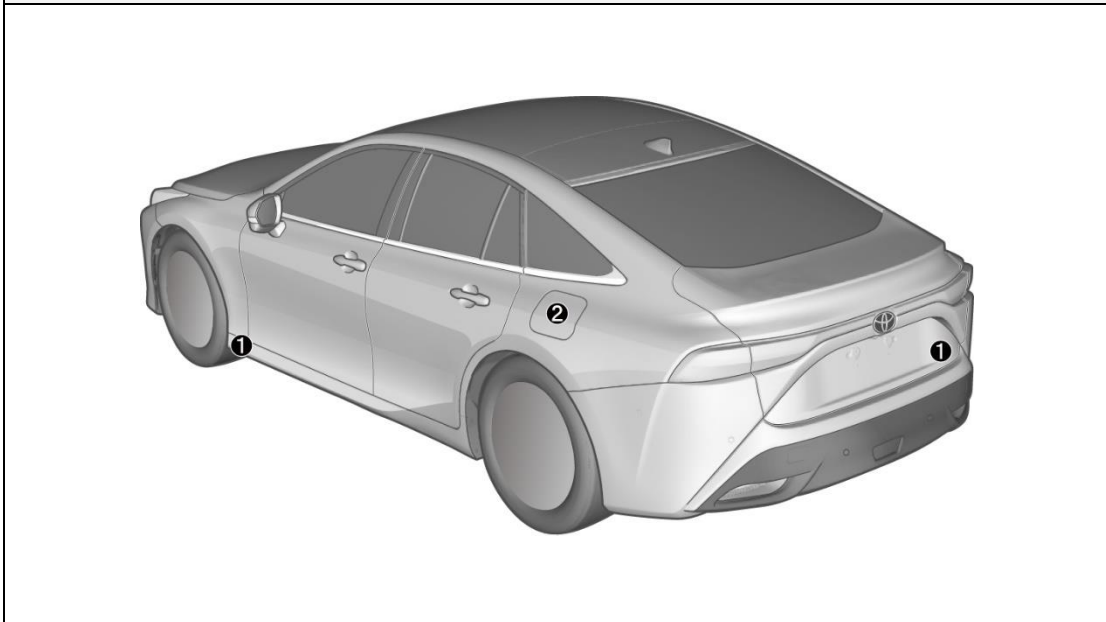

Exterior Rear and Left Side View

Interior

- 3 The combination meter (FC system indicator, **READY** indicator and warning lights) located in the dash behind the steering wheel.

Hint:

If the vehicle is shut off, the combination meter will be “blacked out”, not illuminated.

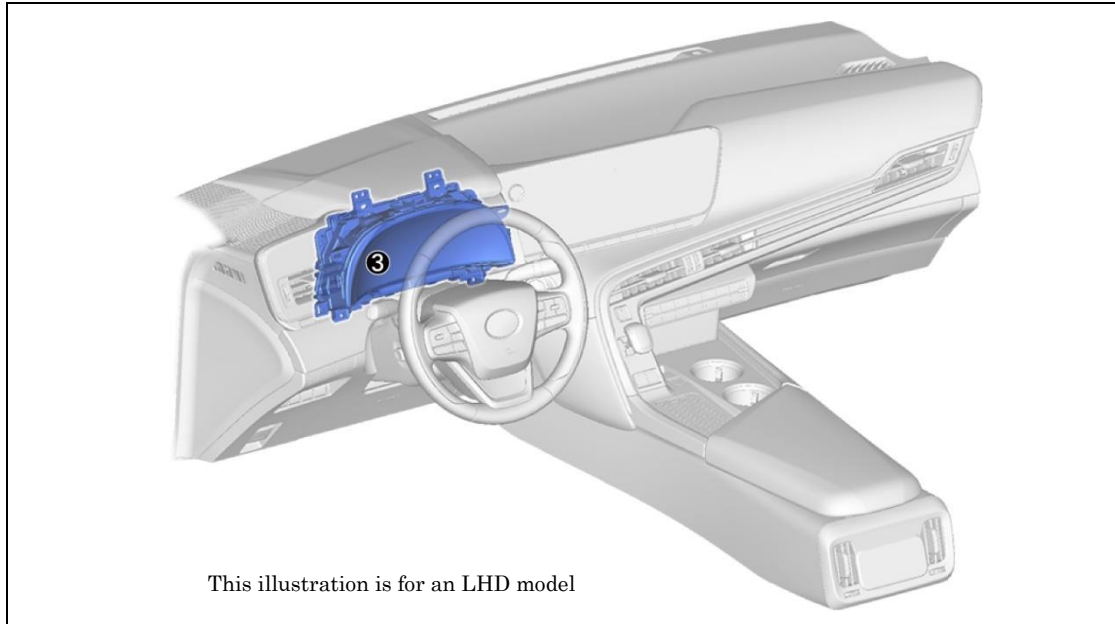

Interior View

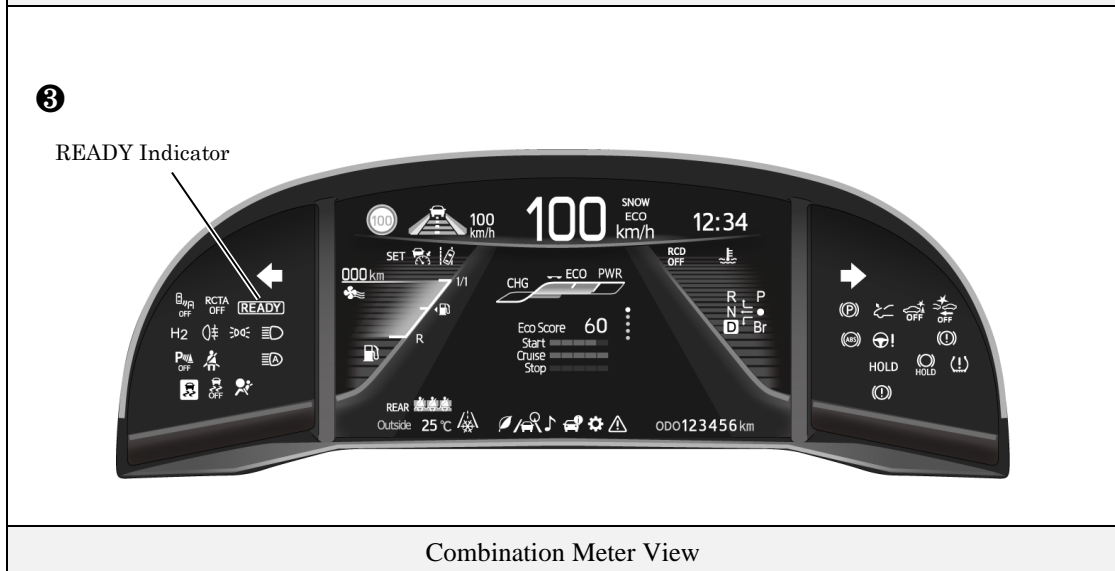

Combination Meter View

Motor Compartment

- ④ FUEL CELL Logo on the plastic upper inverter cover.
- ⑤ Orange colored high voltage power cables.

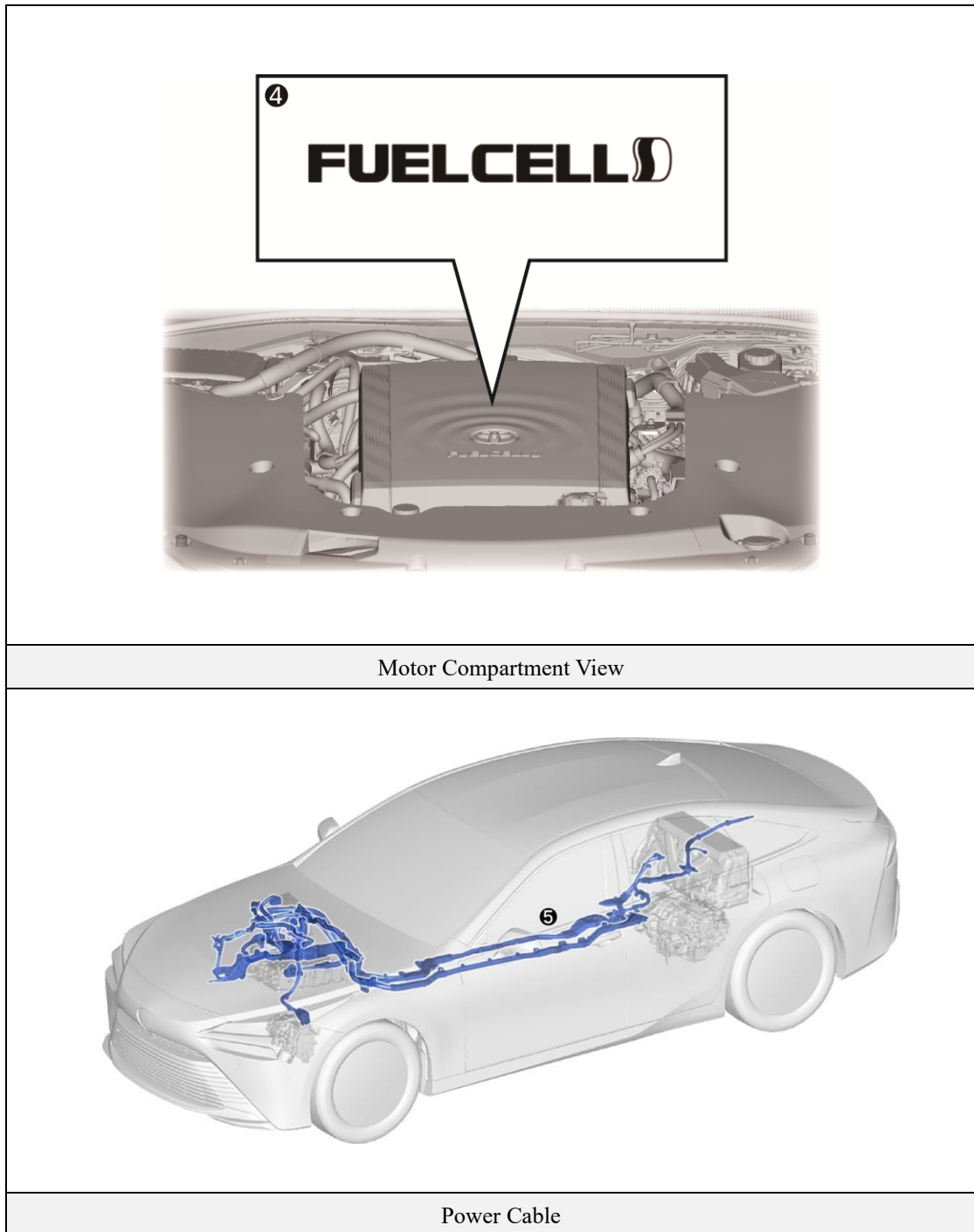

Fuel Cell Vehicle Component Locations & Descriptions

Component	Function
12 Volt Auxiliary Battery ❶	A lead-acid battery that supplies power to the low voltage devices.
EV Supply Battery Assembly ❷	310.8 Volt Lithium-ion (Li-ion) battery pack consisting of 84 low voltage (3.7 Volt) cells connected in series.
Power Cable ❸	<ul style="list-style-type: none"> • Orange colored power cable is a high voltage, high current electrical line. • It is primarily used between the EV supply battery assembly and FC converter assembly, and between the inverter with converter assembly and FC converter assembly.
FC Stack Assembly ❹	Generates electrical energy by causing a chemical reaction between hydrogen fuel from the hydrogen tank and oxygen from the FC air compressor with motor assembly.
FC Converter Assembly ❺	<ul style="list-style-type: none"> • Boosts the voltage of the electrical energy generated in the FC stack assembly to a maximum of DC 650 Volt. • According to requests from the EV control ECU, connects and disconnects the FC main relay and controls the electric power to match the value specified by the electric power request.
Inverter with Converter Assembly ❻	Based on the requested output value from the EV control ECU, controls the electrical power provided to the traction motor and FC air compressor with motor assembly.
DC-DC Converter ❼	Steps down the voltage of the high voltage system to approximately DC 14 Volt and provides it to accessory components and the 12 Volt auxiliary battery.
Hydrogen Recirculation Pump Assembly ❽	Circulates the hydrogen supplied from the fuel injector assembly within the FC stack assembly.

FC Cooling Water Pump Assembly ⑨	Circulates the FC stack coolant, which cools the FC stack assembly and the air compressed by the FC air compressor with motor assembly.
FC Air Compressor with Motor Assembly ⑩	<ul style="list-style-type: none"> • Supercharges the air that has passed the air cleaner and provides it to the FC stack assembly. • Driven by the inverter of the inverter with converter assembly.
FCV Transaxle with Motor Assembly ⑪	Based on driving conditions, uses the electrical energy from the FC stack assembly and the electrical energy from the EV supply battery assembly to generate driving force. Also, uses regenerative braking to generate electricity when decelerating.
Compressor with Motor Assembly ⑫	3-phase high voltage AC electrically driven motor compressor.
Electric Heater Subassembly ⑬	Driven according to air conditioning amplifier assembly and EV control ECU control, and warms the coolant.
Hydrogen Tank ⑭	Employs a hydrogen tank made chiefly of carbon fiber reinforced plastic that can with stand high pressure of 70 MPa (713.8 kgf/cm ² , 10150 psi).
Hydrogen Tank Valve Assembly ⑮	Installed to each hydrogen tank, and opens and closes the hydrogen channels.
Hydrogen Tank Temperature Sensor ⑯	Detects the hydrogen fuel temperature inside the hydrogen tank and transmits it to the hydrogen fuel control ECU.
Hydrogen Supply Regulator Assembly ⑰	Installed between the hydrogen tank and FC stack assembly, and reduces the pressure of the hydrogen fuel from the hydrogen tank to between 1.0 MPa and 1.5 MPa (10.2 kg/cm ² to 15.3 kg/cm ² , 145 psi to 218 psi).

*Numbers in the component column apply to the illustrations on the following page.

Specifications

Electric Motors: 134 kW

EV Battery: 310.8 Volt Sealed Li-ion Battery

Curb Weight: 1,875-1,975 kg / 4,135-4,345 lb

Frame Material: Steel Unibody

Body Material: Steel Panels

Seating Capacity: 5 passenger

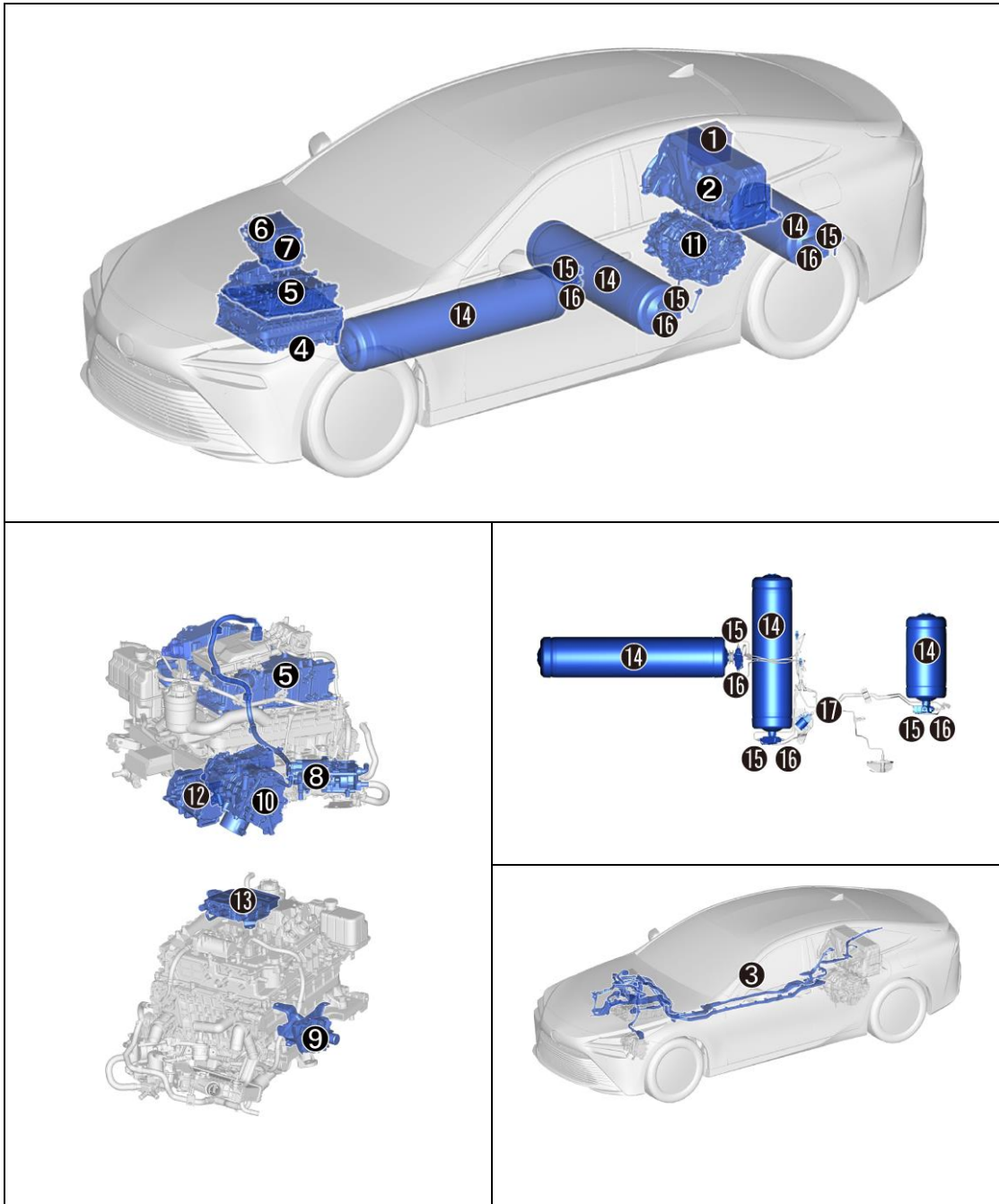

Fuel Cell Vehicle Operation

Once the **READY** indicator is illuminated in the combination meter, the vehicle may be driven. When starting and stopping, the FC main relay built into the FC converter assembly and the hydrogen tank valve installed to the hydrogen tank are actuated, which causes an operating sound to be heard.

It is important to recognize and understand the **READY** indicator provided in the instrument cluster. When illuminated, it informs the driver that the vehicle is on and operational even though the motor compartment is silent.

Vehicle Operation

- With the MIRAI, the system is operational while the **READY** indicator is on.
- Never assume that the vehicle is shut off just because the motor compartment is silent.

Always look for the **READY** indicator status. The vehicle is shut off when the **READY** indicator is off.

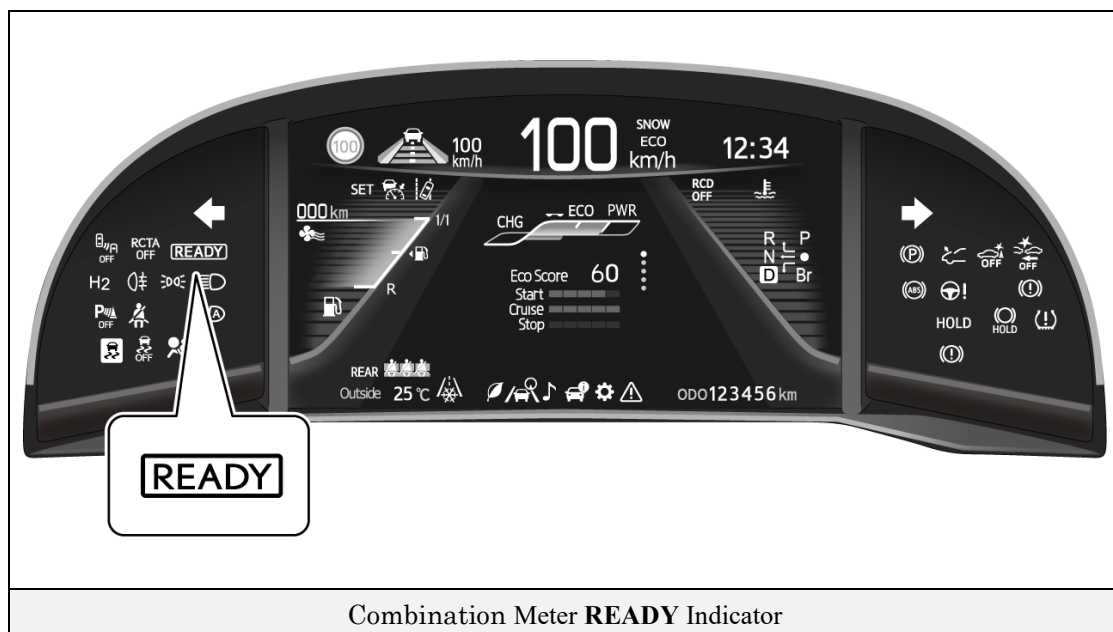

EV Battery and Auxiliary Battery

The MIRAI features a high voltage EV battery that contains sealed Lithium-ion (Li-ion) battery cells.

EV Battery

- The EV battery is enclosed in a metal case and is rigidly mounted to the luggage room in the rear seat back. The metal case is isolated from high voltage.
- The EV battery consists of 84 low voltage (3.7 Volt) Li-ion battery cells connected in series to produce approximately 310.8 Volts. Each NiMH battery cells is non-spillable and sealed in a metal case.
- The electrolyte used in the Li-ion battery cell is a flammable organic electrolyte. The electrolyte is absorbed into the battery cell separator and will not normally leak, even in a collision.

EV Battery	
Battery assembly voltage	310.8 Volts
Number of Li-ion battery cells in the pack	84
Li-ion battery cells voltage	3.7 Volts

Components Powered by the EV Battery

- Compressor with Motor Assembly
- Electric Heater Sub-assembly
- FC Air Compressor with Motor Assembly
- DC/DC Converter*
- Inverter with Converter Assembly
 - DC-DC Converter for 12 Volt Auxiliary Battery
- FCV Transaxle with Motor Assembly
- FC Converter Assembly
- FC Cooling Water Pump Assembly
- Hydrogen Recirculation Pump Assembly
- Voltage Inverter Assembly*

*: Option

EV Battery Recycling

- The EV battery is recyclable. Contact either your Toyota distributor as mentioned on EV battery Caution Label or the nearest Toyota dealer.

Auxiliary Battery

- The MIRAI also contains a sealed lead-acid 12 Volt battery. This 12 Volt auxiliary battery powers the vehicle electrical system similar to a conventional vehicle. As with other conventional vehicles, the auxiliary battery is grounded to the metal chassis of the vehicle.
- The auxiliary battery is located in the trunk area. It is concealed by a fabric cover on the right side in the rear quarter panel well.

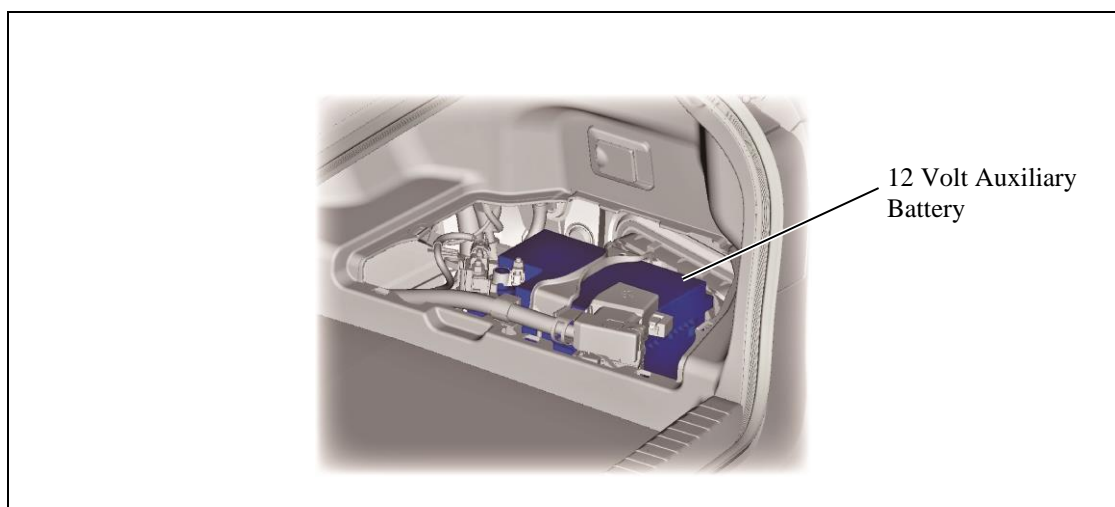

12 Volt Auxiliary Battery Mounted in Trunk Area (Right Side)

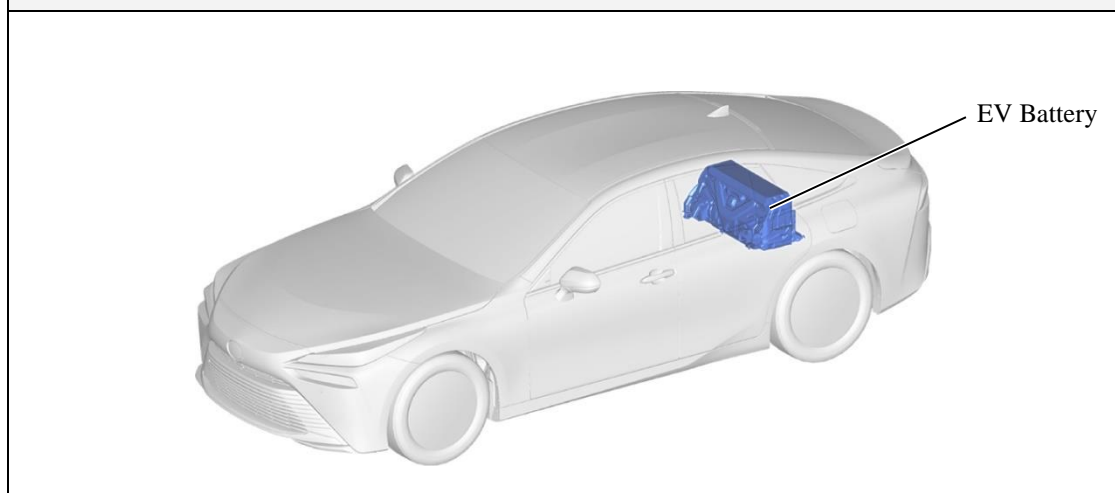

EV Battery

Hydrogen Safety

About Hydrogen

Hydrogen can be produced using a number of primary energy sources other than petroleum, such as natural gas or ethanol. Also, solar power or wind power can be used to produce hydrogen from water.

Characteristics of Hydrogen

Compared to gasoline, hydrogen has disadvantages such as "easy leakage due to small molecular size", "odorless and colorless and thus difficult to detect", and "highly flammable at a wide range of concentrations". However, it also has advantages such as "easily dispersed due to low specific gravity", "does not easily auto ignite due to high ignition temperature", and due to the wide detonation concentration range, "does not easily explode" unless confined in an enclosed space together with oxygen.

Item	Hydrogen	Natural Gas	Gasoline	Hydrogen Characteristics
Molecular Weight	2	16	106	Leaks easily
Coloring / Odor	None	Colorless / Odorant can be added	Yes	Difficult to detect leaks
Flammability Concentration Range	4.0 - 74.5%	5.3 - 15.0%	1.0 - 7.6%	Burns readily
Detonation Concentration Range	18.3 - 59%	6.3 - 13.5%	1.1 - 3.3%	Does not readily explode
Specific Gravity (air=1)	0.07	0.55	3.4 - 4.0	Easily dispersed
Ignition Temperature	527(°C)	540(°C)	228(°C)	Difficult to ignite

Basic Safety Concepts for Hydrogen System Components

Prevent Leaks	Difficult-to-leak Design	The connection portions of hydrogen fuel piping have been designed with a strong focus on leak prevention.
	Selection of Materials	Appropriate materials have been selected with regard to hydrogen embrittlement
Detect and Stop	Equip with Hydrogen Detector	In the unlikely event that a hydrogen leak occurs, the hydrogen detector detects the leaked hydrogen and the hydrogen tank valve operates to prevent a large leak of hydrogen fuel.
	Equip with Collision Sensor	If the vehicle receives an impact that is judged to be a collision, the hydrogen tank valve operates to prevent a large leak of hydrogen fuel.
Prevent Accumulation of Leaked Hydrogen		In the unlikely event that hydrogen fuel leaks out, the vehicle is designed to prevent the leaked hydrogen from remaining inside.
Keep Ignition Sources Away		The vehicle is designed so that potential ignition sources are not located near the hydrogen system.

Caution

Fuel cell vehicles use high pressure hydrogen fuel at 70 MPa, and improper handling can cause hydrogen leakage possibly resulting in vehicle fires or explosions.

High Voltage Safety

The EV battery powers the high voltage electrical system with DC electricity. The power cable is a high voltage, high current electrical line. It is primarily used between the EV supply battery assembly and FC converter assembly, and between the inverter with converter assembly and FC converter assembly. To enable technicians to visually distinguish between the high voltage power cable and the normal low voltage electrical lines, the power cable and its corrugated tube have been standardized with an orange color. The inverter with converter contains a circuit that boosts the EV battery voltage from 310.8 to 650 Volts DC. The inverter with converter creates 3-phase AC to power the motors.

The following systems are intended to help keep occupants in the vehicle and emergency responders safe from high voltage electricity:

High Voltage Safety System

- A high voltage fuse ❶* provides short circuit protection in the EV battery.
- Positive and negative high voltage power cables ❷* connected to the EV battery and FC converter assembly are controlled by 12 Volt normally open relays ❸*. When the vehicle is shut off, the relays stop electricity flow from leaving the EV battery.



WARNING:

- ***The high voltage system may remain powered for up to 10 minutes after the vehicle is shut off or disabled. To prevent serious injury or death from severe burns or electric shock, avoid touching, cutting, or opening any orange high voltage power cable or high voltage component.***

- Both positive and negative power cables ❷* are insulated from the metal body. High voltage electricity flows through these cables and not through the metal vehicle body.
The metal vehicle body is safe to touch because it is insulated from the high voltage components.
- A ground fault monitor ❹* continuously monitors for high voltage leakage to the metal chassis while the vehicle is running. If a malfunction is detected, the EV control computer ❹* will indicate “FC System Malfunction” on the multi-information display.
- The EV battery relays will automatically open to stop electricity flow in a collision sufficient to activate the SRS.

Service Plug Grip

- The high voltage circuit is cut by removing the service plug grip (see page 77).

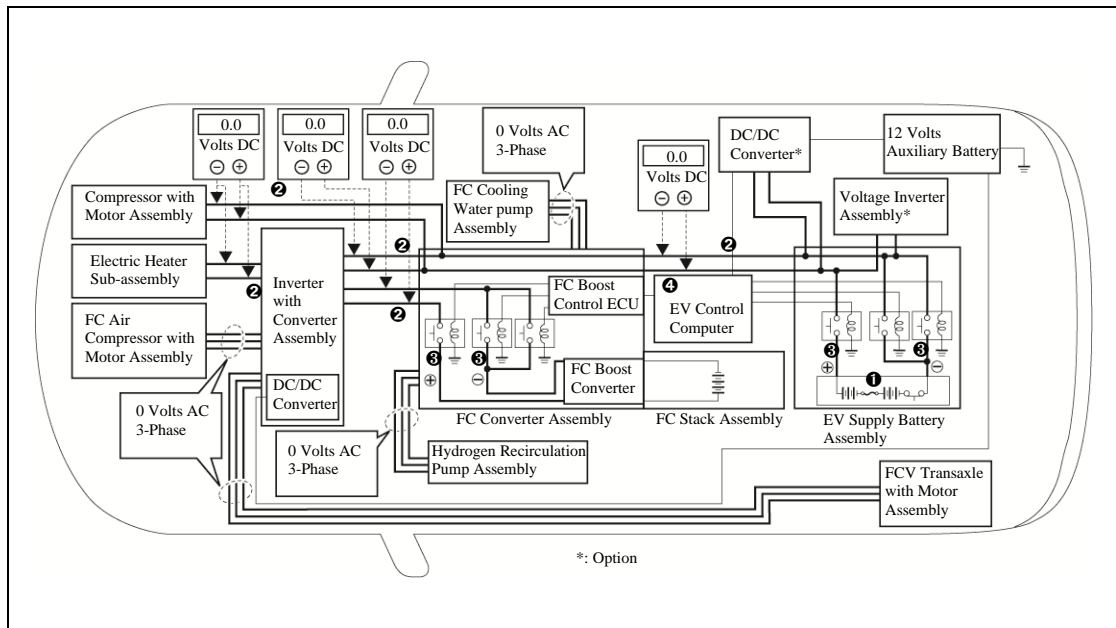

High Voltage Safety System – Vehicle Shut Off (READY-OFF)

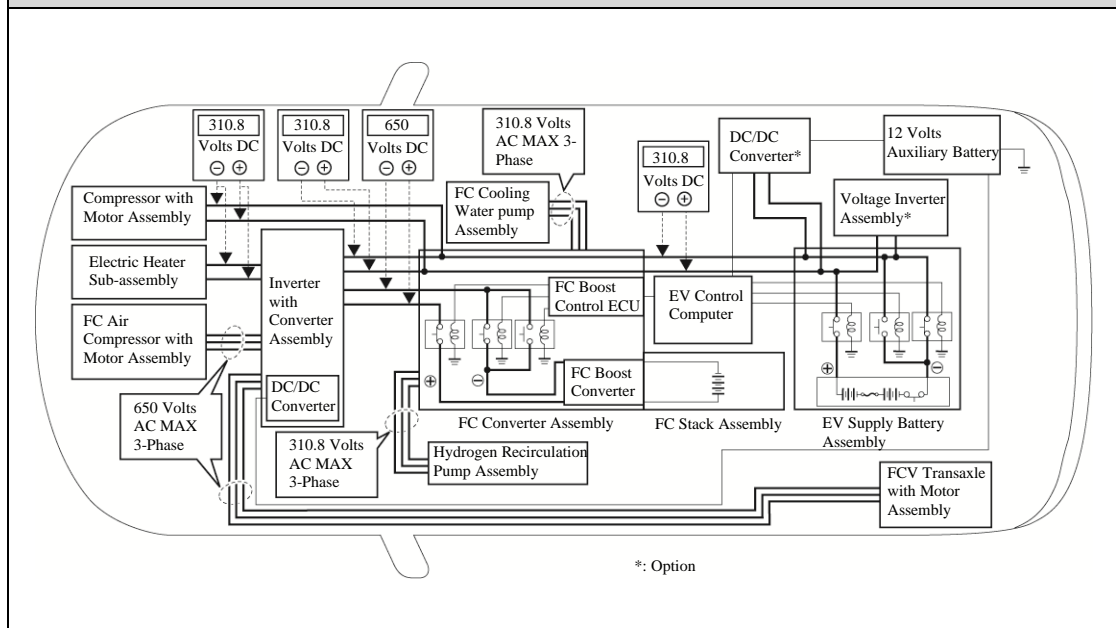

High Voltage Safety System – Vehicle On and Operational (READY-ON)

Precaution to be observed when dismantling the vehicle



WARNING:

- *The high voltage system may remain powered for up to 10 minutes after the vehicle is shut off or disabled. To prevent serious injury or death from severe burns or electric shock, avoid touching, cutting, or opening any orange high voltage power cable or high voltage component.*
- *When discharging pressurized hydrogen gas from the from the hydrogen tank assembly, do not perform the procedure in an indoor area with poor ventilation.*
- *Do not install or remove any hydrogen system components without first performing depressurization procedures.*

Necessary Items

- Protective clothing such as insulated gloves (electrically insulated), rubber gloves, safety goggles, and safety shoes.
- Insulating tape such as electrical tape that has a suitable electrical insulation rating.
- Before wearing insulated gloves, make sure that they are not cracked, ruptured, torn, or damaged in any way. Do not wear wet insulated gloves.
- An electrical tester that is capable of measuring DC 750 Volts or more.

Spills

The MIRAI contains the same common automotive fluids used in other non-hybrid Toyota vehicles, with the exception of the Li-ion electrolyte used in the HV battery pack. The electrolyte used in the Li-ion battery cells is a flammable organic electrolyte. The electrolyte is absorbed into the battery cell separators, even if the battery cells are crushed or cracked, it is unlikely that liquid electrolyte will leak. Any liquid electrolyte that leaks from a Li-ion battery cell quickly evaporates.



WARNING:

- ***The Li-ion battery contains organic electrolyte. Only a small amount may leak from the batteries which may irritate the eyes, nose, throat, and skin.***
- ***Contact with the vapor produced by the electrolyte may irritate the nose and throat.***
- ***To avoid injury by coming in contact with the electrolyte or vapor, wear personal protective equipment for organic electrolyte including SCBA or protective mask for organic gases.***

- Handle Li-ion electrolyte spills using the following Personal Protective Equipment (PPE):
 - Splash shield or safety goggles. A fold down face shield is not acceptable for acid or electrolyte spills.
 - Rubber gloves or gloves suitable for organic solvents.
 - Apron suitable for organic solvents.
 - Rubber boots or boots suitable for organic solvents.
 - Protective mask for organic gases or SCBA.

Dismantling the vehicle

Caution

- The hydrogen tanks contain high-pressure hydrogen.
- Never dismantle a vehicle without first removing and depressurizing the hydrogen tanks. Failure to observe this precaution may lead to serious injury or death caused by high-pressure gas.

How to Proceed with Work

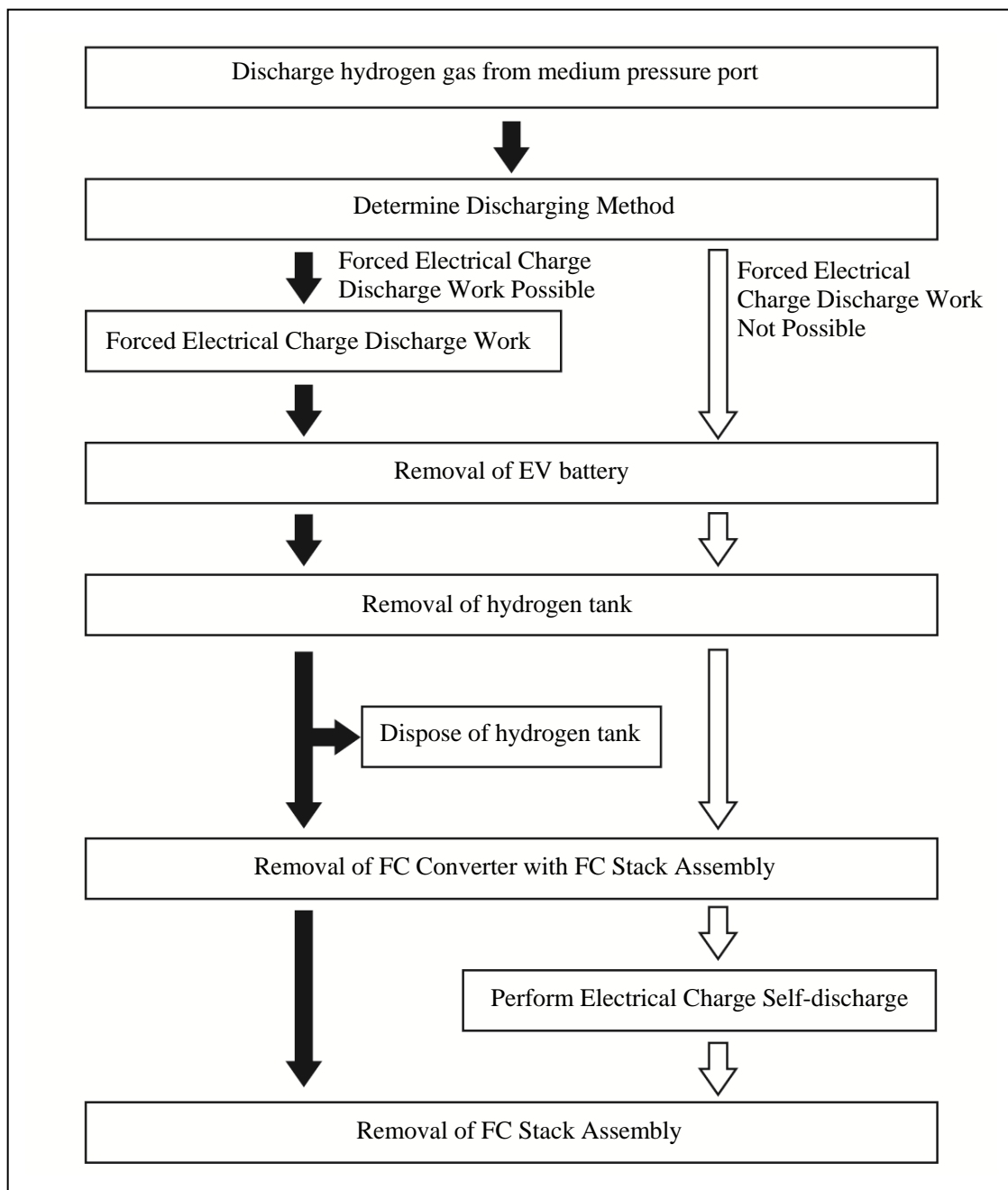

Discharge Hydrogen Gas from Medium Pressure Port

The following 3 pages contain general instructions for use when working on a MIRAI. Read these instructions before proceeding to the discharge hydrogen gas from medium pressure port instructions on page 23.

HINT:

These procedures are only performed when discharging compressed hydrogen gas from the hydrogen tank assemblies.

Caution:

- When discharging pressurized hydrogen gas from the hydrogen tank assembly, do not perform the procedure in an indoor area with poor ventilation.

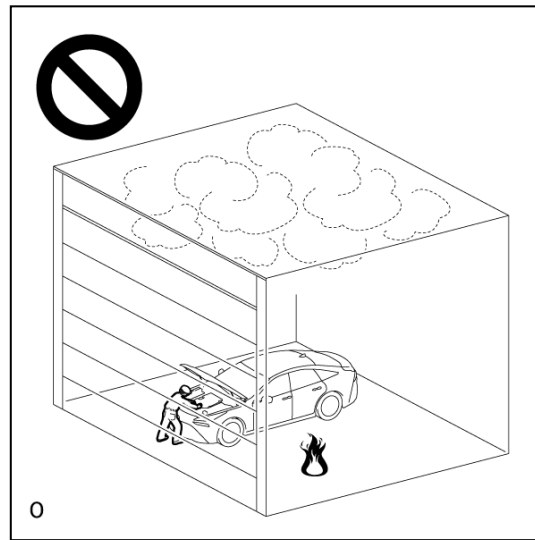

- Accumulated hydrogen gas could ignite, resulting in a serious accident.
- Do not install or remove any hydrogen system components without first performing depressurization procedures.

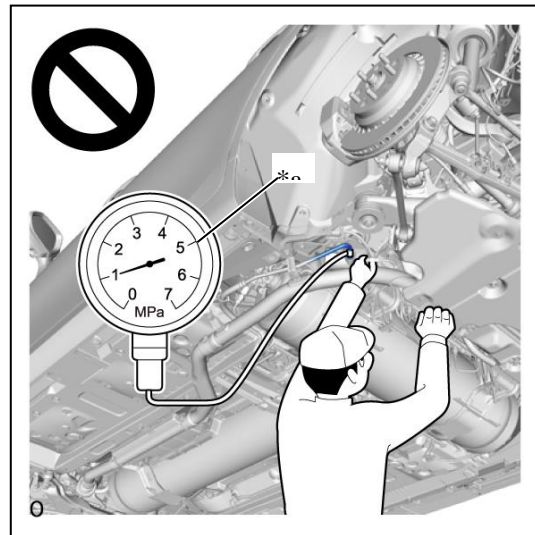

- The highly pressurized hydrogen gas inside the hydrogen tank assembly could blow out, resulting in a serious accident.

*a	When inside of piping is pressurized
----	--------------------------------------

- Do not perform depressurization procedures when the manual valve of the hydrogen tank assembly is open.

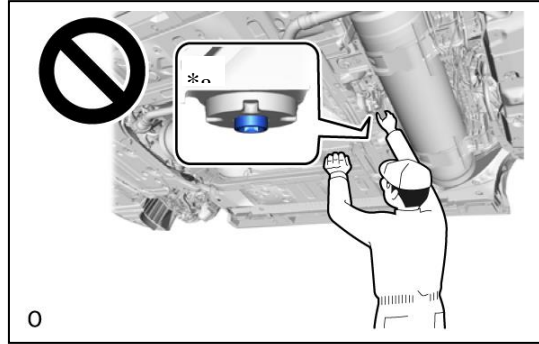

*a	Manual Valve Open
----	-------------------

- The highly pressurized hydrogen gas inside the hydrogen tank assembly could blow out, resulting in a serious accident.
- When performing depressurization, do not perform procedures by hand without wearing protective glasses and gloves.

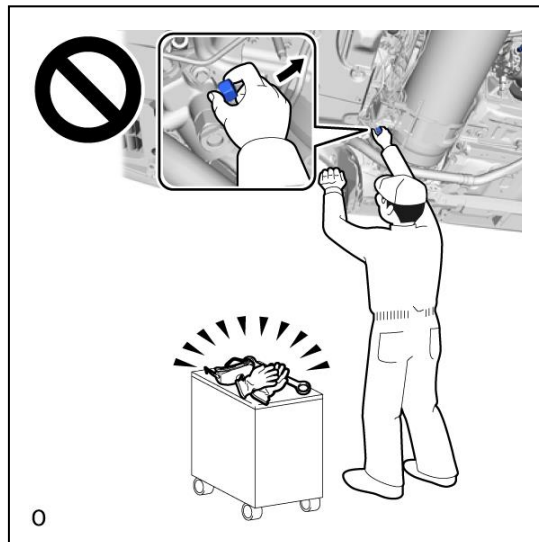

- The highly pressurized hydrogen gas inside the hydrogen tank assembly could blow out, resulting in a serious accident.
- When discharging pressurized hydrogen gas from the hydrogen tank assembly, do not perform the procedure in an indoor area with poor ventilation.

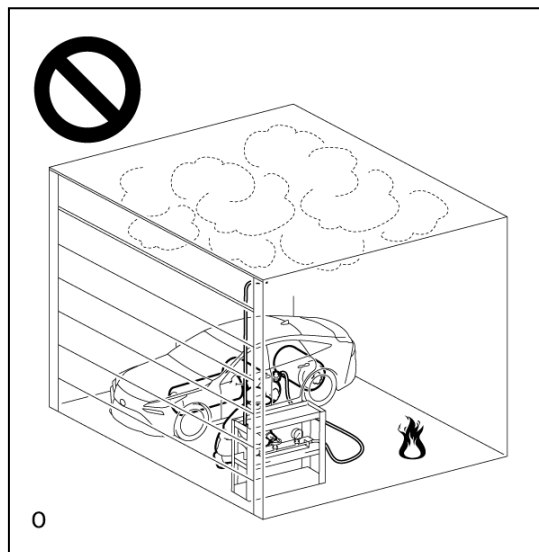

- Accumulated hydrogen gas could ignite, resulting in a serious accident.

- While discharging pressurized hydrogen gas, the temperature inside the tank decreases and frost may form on the outside. Do not touch tanks, piping, or SST (hydrogen venting tool) when frost has formed on them.

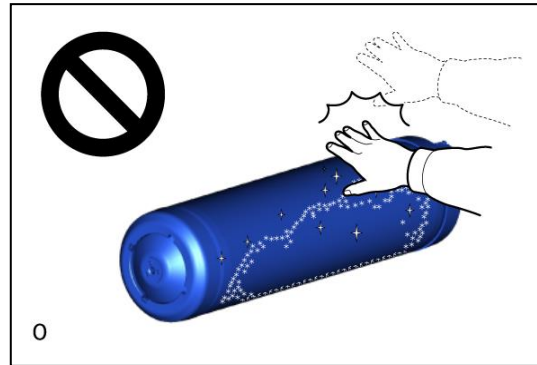

- Touching tanks, piping, or SST (hydrogen venting tool) on which frost has formed could result in burn-like injuries due to frostbite.
- When opening the tank shut valve and applying pressure to SST (hydrogen venting tool), stay away from the SST (flexible hose).

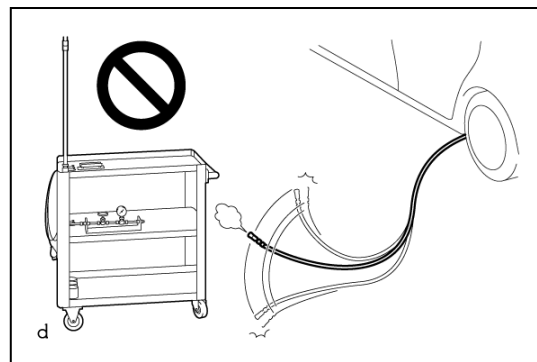

- If SST (flexible hose) comes off, you could be struck by the loose end of SST (flexible hose), causing a serious accident.

Notice:



- After turning the ignition switch off, waiting time may be required before disconnecting the cable from the negative (-) auxiliary battery terminal.
- When performing depressurization, do not open or close any parts of the hydrogen gas piping except for the following:
 - Adjustment bolt of the hydrogen tank assembly manual valve
 - Tank shut valve of the hydrogen tank assembly
 - No. 1 hydrogen supply regulator plug
- Place signs [HIGH PRESSURE GAS WORK IN PROGRESS - DO NOT TOUCH!], etc. to warn other technicians to be cautious. (An example sign is included, so make a copy and use it.)

<hr style="border-top: 1px dashed black;"/> <hr style="border-top: 1px solid black;"/>
<p>Person in charge:</p> <p>DO NOT TOUCH.</p> <p>HIGH-PRESSURE GAS</p> <p>CAUTION:</p>
<hr style="border-top: 1px dashed black;"/>
<p>CAUTION:</p> <p>HIGH-PRESSURE GAS</p> <p>DO NOT TOUCH.</p> <p>Person in charge:</p> <hr style="border-top: 1px solid black;"/>
<hr style="border-top: 1px dashed black;"/>
<p>Place signs [HIGH PRESSURE GAS WORK IN PROGRESS - DO NOT TOUCH!], etc. to warn other technicians to be cautious. (An example sign is included, so make a copy and use it.)</p>

1. REMOVE REAR NO. 4 FLOOR BOARD SUB-ASSEMBLY

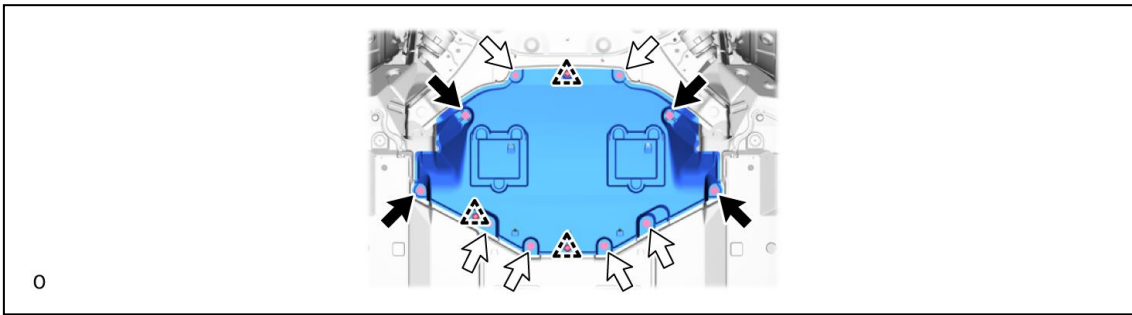
a.





	Bolt		Screw
---	------	---	-------

2. REMOVE REAR NO. 3 FLOOR BOARD SUB-ASSEMBLY

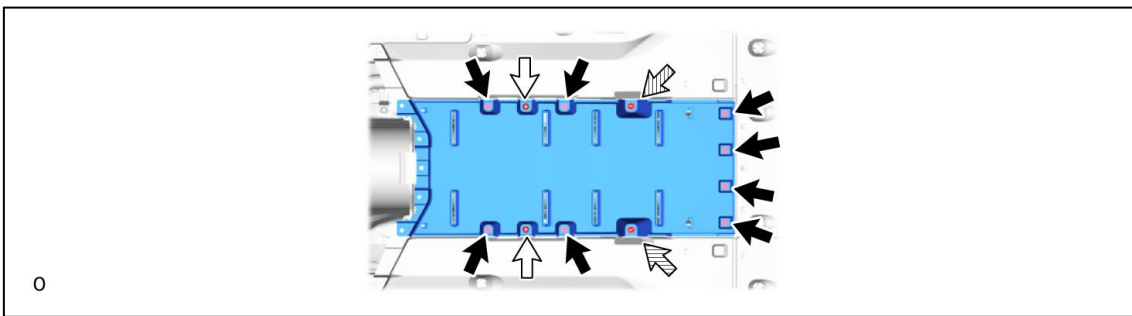
a.





	Screw		Nut
	Grommet	-	-

3. REMOVE NO. 2 FLOOR BOARD SUB-ASSEMBLY

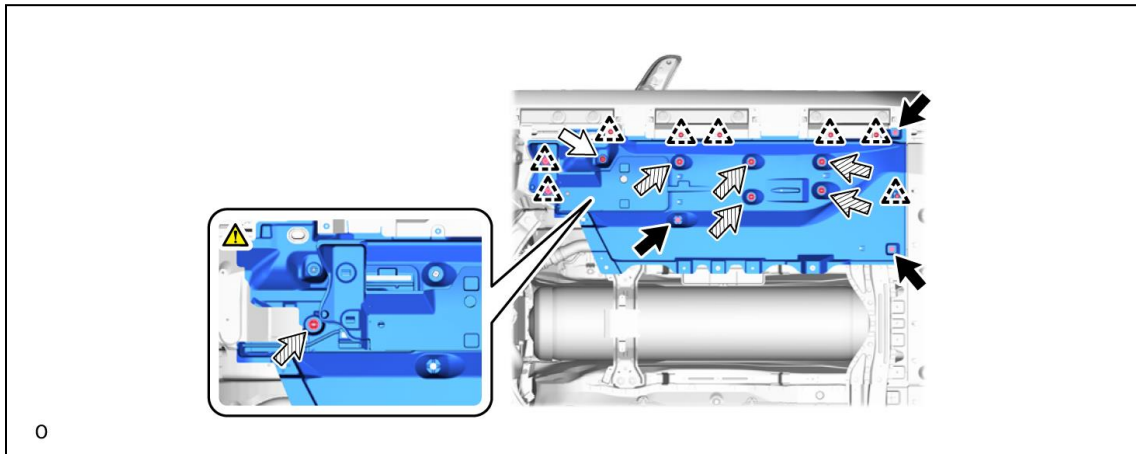
a.



	Bolt		Nut
	Grommet	-	-

- (1) Remove the 3 bolts and nut, detach the 8 clips and loosen the 5 grommets.
- (2) Slide the cover and loosen the grommet and remove the No. 2 floor board sub-assembly.

4. REMOVE REAR FLOOR SIDE MEMBER COVER LH

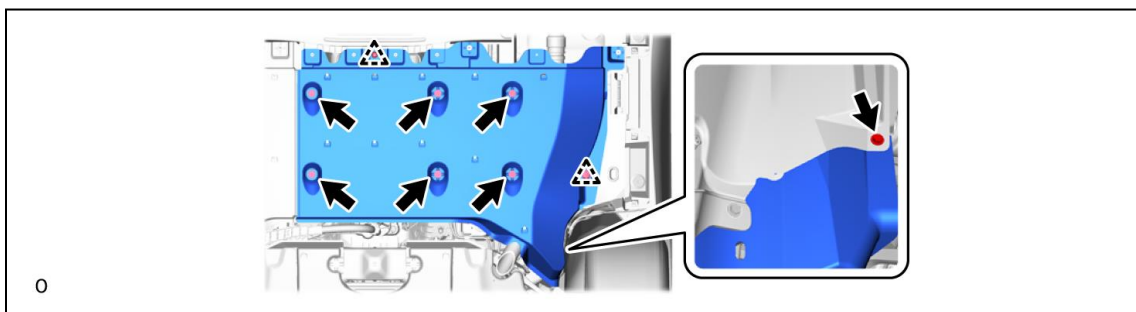

a.

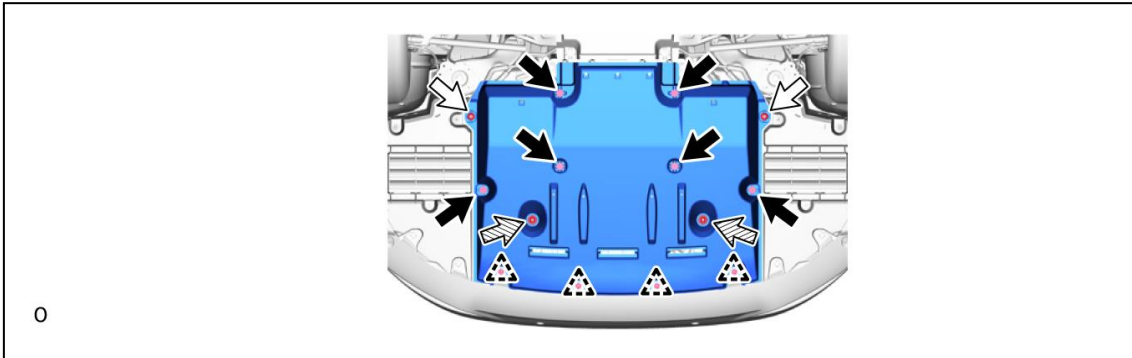

5. REMOVE NO. 1 FLOOR UNDER COVER (for 3 Hydrogen Tank)

a.



	Bolt		Nut
	Grommet	-	-

6. PREPARE SST (HYDROGEN VENTING TOOL)

Hint:

Before performing work, check the set up conditions of SST (hydrogen venting tool).

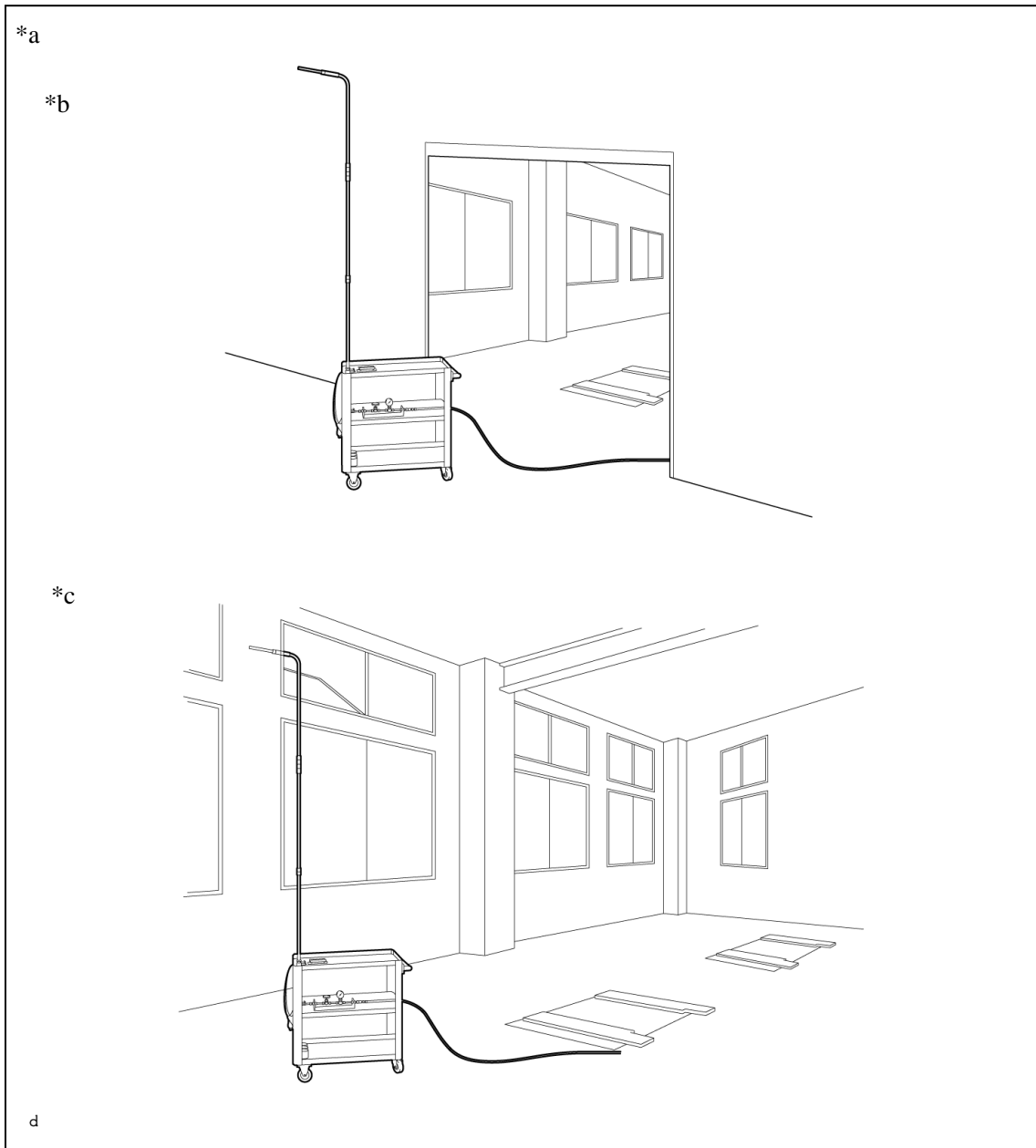

*a	Hydrogen Gas Discharging Conditions	*b	Basic Conditions
*c	Other than Basic Conditions (if mechanism cannot be set up outdoors)	-	-

a. Check the assembly of SST (hydrogen venting tool).

SST

09404-62010 (09404-06010, 09404-06020, 09404-06030, 09404-06040, 09404-06050, 09404-06060)

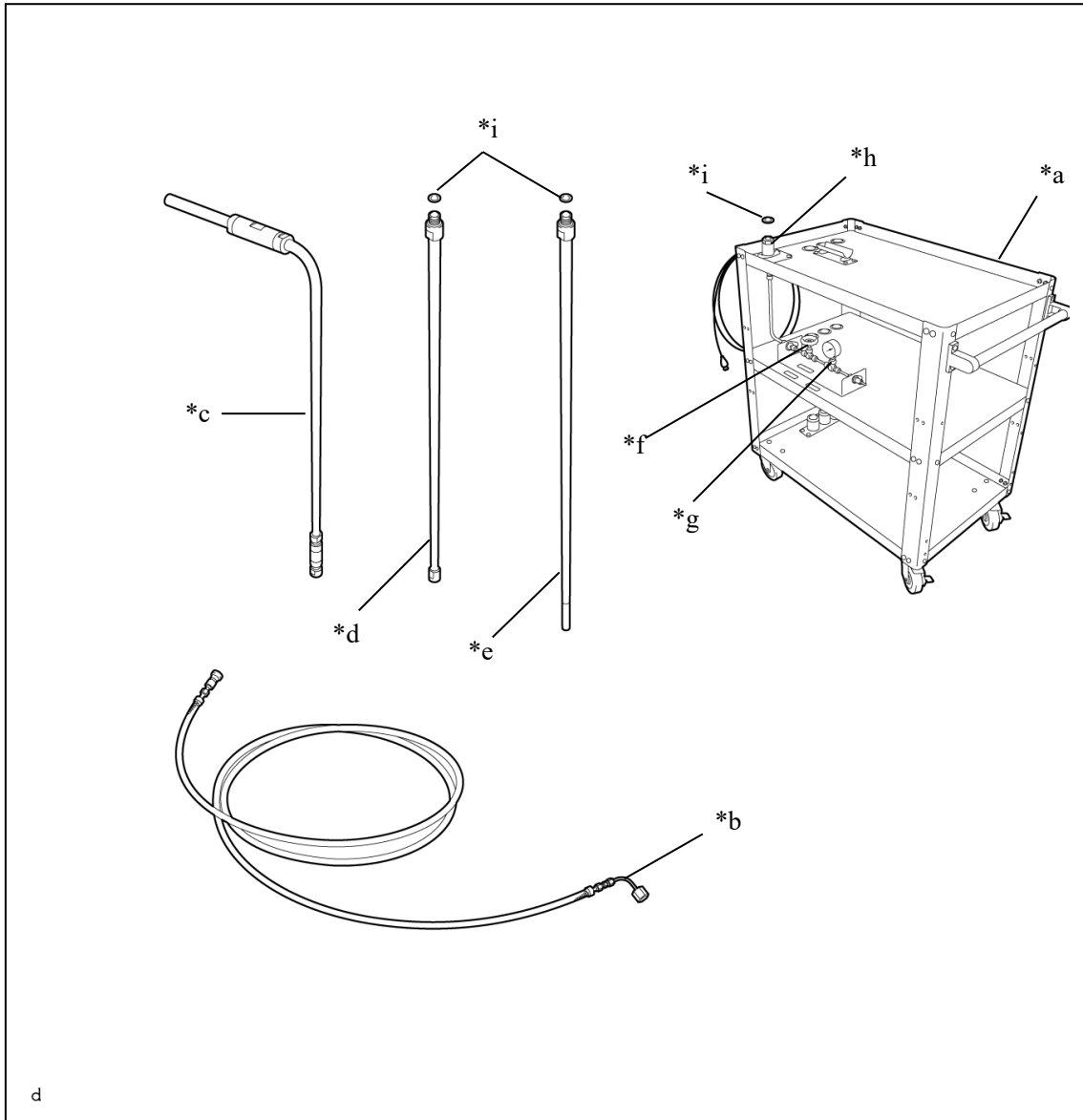

*a	SST (Venting Stand)	*b	SST (Flexible Hose)
*c	SST (Upper Release Pipe)	*d	SST (Middle Release Pipe)
*e	SST (Lower Release Pipe)	*f	Open/close Valve
*g	Pressure Gauge	*h	Discharge Pipe Support
*i	SST (O Ring (Replace at time of using SST (hydrogen venting tool)))	-	-

b. Make sure to replace SST (3 O-rings) of SST (hydrogen venting tool) with new ones.

- (1) Remove SST (O-ring) from SST
(middle release pipe).

SST

09404-62010 (09404-06060, 09404-06040)

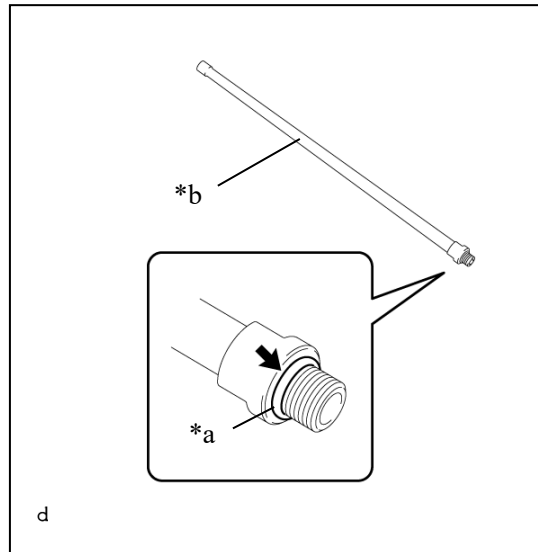

*a	SST (O-ring)
*b	SST (Middle Release Pipe)

- (2) Install a new SST (O-ring) to SST
(middle release pipe).

SST

09404-62010 (09404-06040, 09404-06060)

- (3) Remove SST (O-ring) from SST (lower
release pipe).

SST

09404-62010 (09404-06050, 09404-06060)

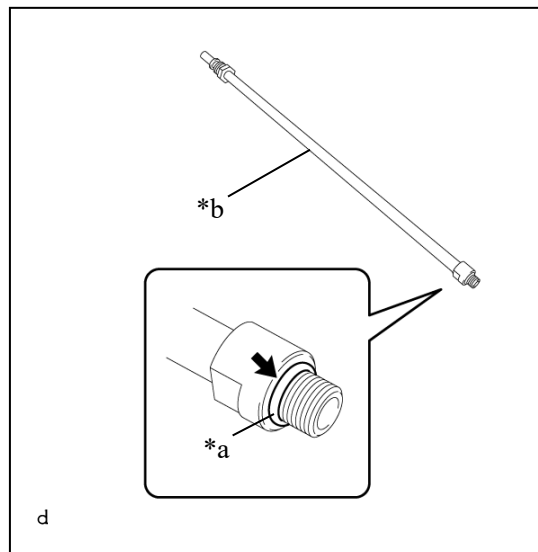

*a	SST (O-ring)
*b	SST (Lower Release Pipe)

- (4) Install a new SST (O-ring) to SST (lower release pipe).

SST

09404-62010 (09404-06050, 09404-06060)

- (5) Using a thin-bladed screwdriver with its tip wrapped in protective tape, remove SST (O-ring) from the release pipe support.

SST

09404-62010 (09404-06010, 09404-06060)

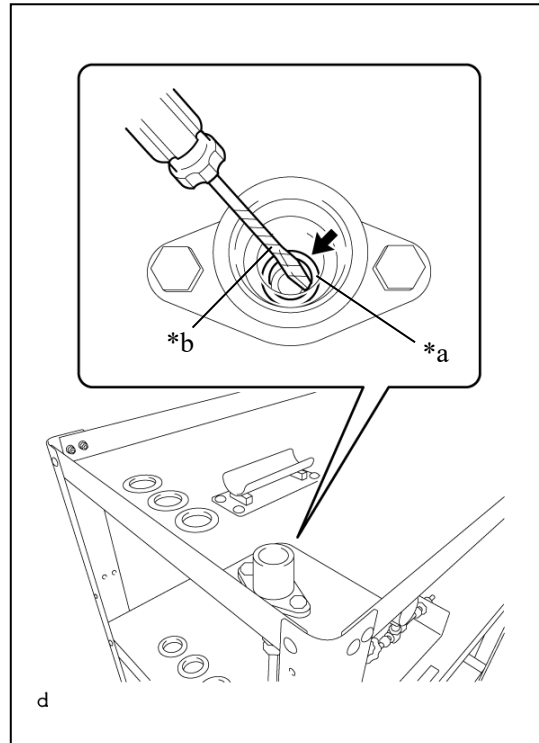

*a	SST (O-ring)
*b	Protective Tape

- (6) As shown in the illustration, install a new SST (O-ring) to the release pipe support.

SST

09404-62010 (09404-06060)

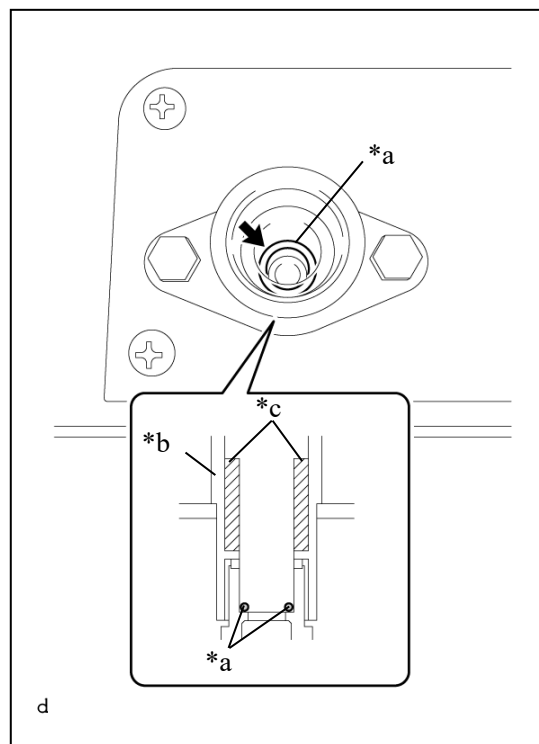

*a	SST (O-ring)
*b	Release Pipe Support
*c	Collar

c. Connect each part of SST (hydrogen venting tool) and prepare it for use.

- (1) Connect SST (upper release pipe) and SST (middle release pipe), and using a thickness gauge, measure the clearance in the location shown in the illustration.

SST

09404-62010 (09404-06030, 09404-06040, 09404-06060)

Discharge pipe connection

clearance:

1.7 mm (0.0669 in.)

Notice:

Perform the procedure by hand. Do not use any tools.

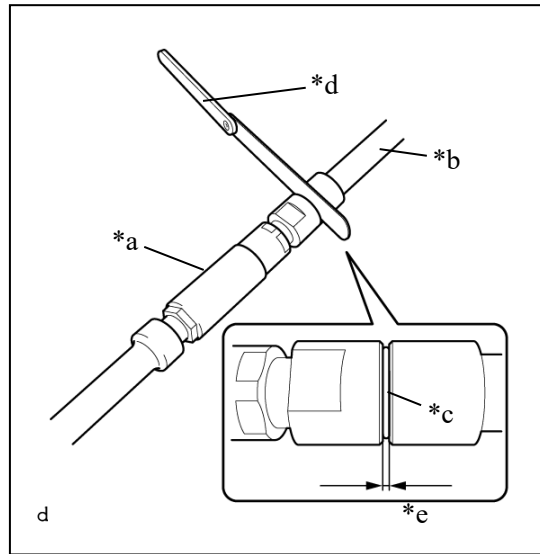

*a	SST (Upper Release Pipe)
*b	SST (Middle Release Pipe)
*c	SST (O-ring)
*d	Thickness Gauge
*e	1.7 mm (0.0669 in.)

- (2) Connect SST (middle release pipe) and SST (lower release pipe), and using a thickness gauge, measure the clearance in the location shown in the illustration.

SST

09404-62010 (09404-06040, 09404-06050, 09404-06060)

Discharge pipe connection

clearance:

1.7 mm (0.0669 in.)

Notice:

Perform the procedure by hand. Do not use any tools.

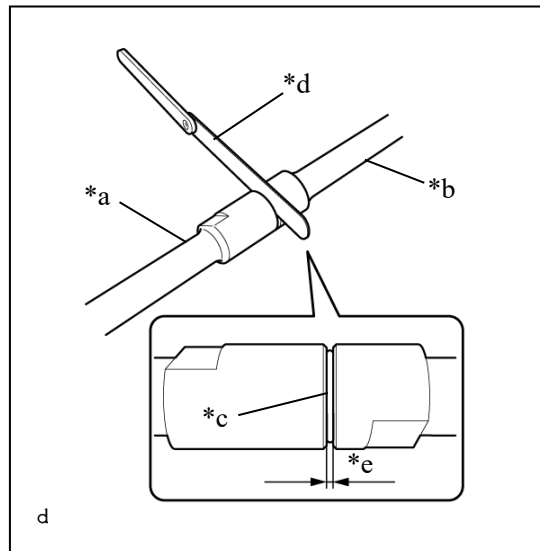

*a	SST (Middle Release Pipe)
*b	SST (Lower Release Pipe)
*c	SST (O-ring)
*d	Thickness Gauge
*e	1.7 mm (0.0669 in.)

- (3) Connect SST (lower release pipe) to the release pipe support, and using SST (variable open wrench), tighten the nut.

SST

09922-10010

09404-62010 (09404-06050)

Torque:

Specified tightening torque

20 N*m (204 kgf*cm, 15 ft.*lbf)

Hint:

- Calculate the torque wrench reading when changing the fulcrum length of the torque wrench.
- When using SST (fulcrum length of 136 mm (5.35 in.)) + torque wrench (fulcrum length of 180 mm (7.09 in.)): 11.4 N*m (116 kgf*cm, 8 ft.*lbf)

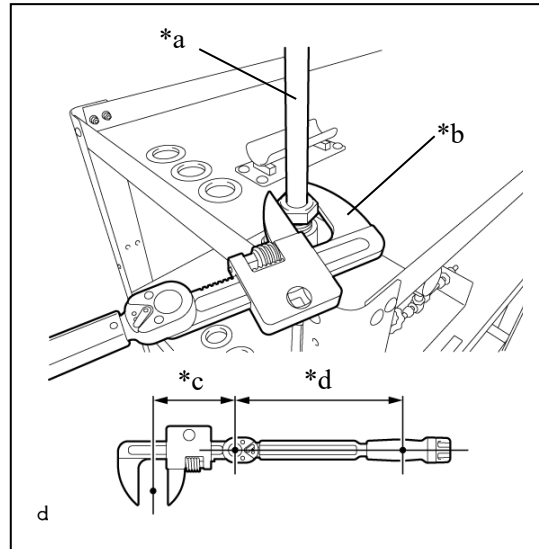

*a	SST (Lower Release Pipe)
*b	SST (Variable Open Wrench)
*c	SST Fulcrum Length
*d	Torque Wrench Fulcrum Length

- (4) Connect the ground wire.

Notice:

Connect the ground wire to somewhere that will enable secure electrical grounding.

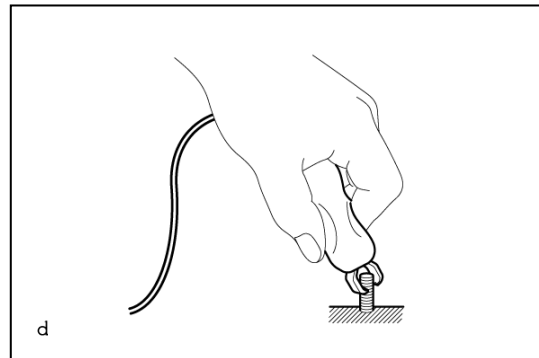

7. REMOVE NO. 3 FC EXHAUST PIPE

	<p>CAUTION:</p> <ul style="list-style-type: none">• If the water remaining inside the No. 3 FC exhaust pipe is hot, do not touch the water directly.• Touching the water remaining inside the No. 3 FC exhaust pipe when it is hot could result in burns.
---	---

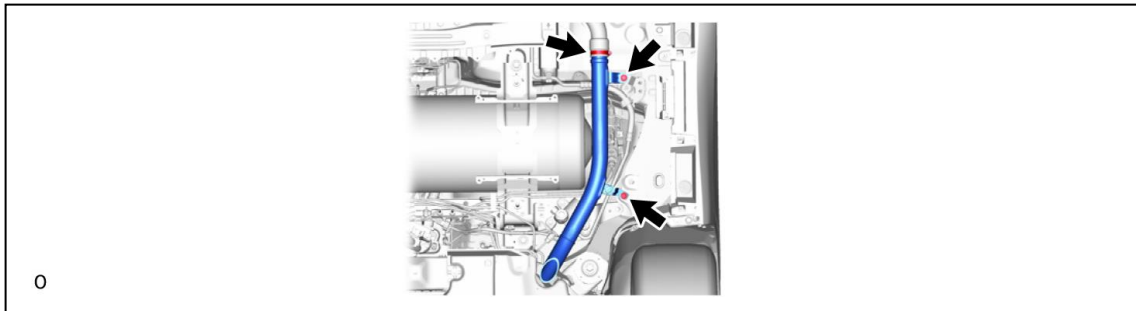

8. CONNECT SST (HYDROGEN VENTING TOOL)

- a. Check that the open/close valve of SST (venting stand) is closed.

SST

09404-62010 (09404-06010)

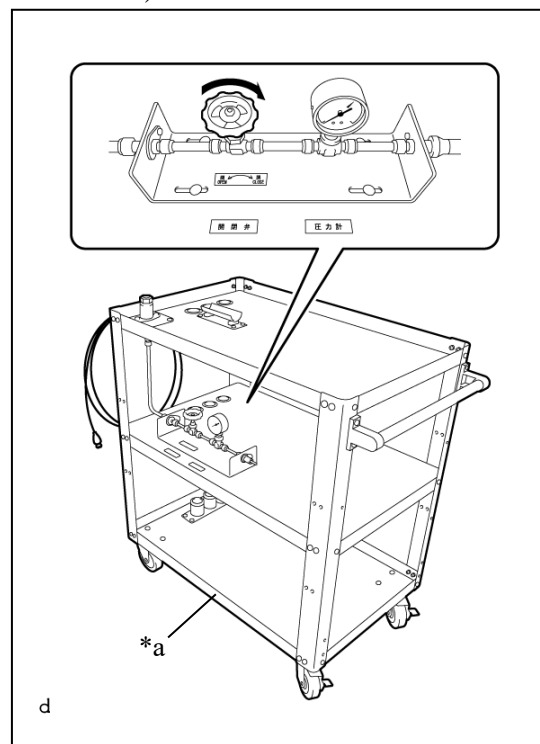

*a	SST (Venting Stand)
----	---------------------

- b. Using an 8 mm hexagon socket wrench, rotate the adjustment bolt clockwise to close the manual valve of the No. 1 hydrogen tank assembly.

Torque:

25 N*m (255 kgf*cm, 18 ft.*lbf)

Notice:

The manual valve shuts off the pressure from the hydrogen tank assembly, so be careful not to damage the hexagonal portion.

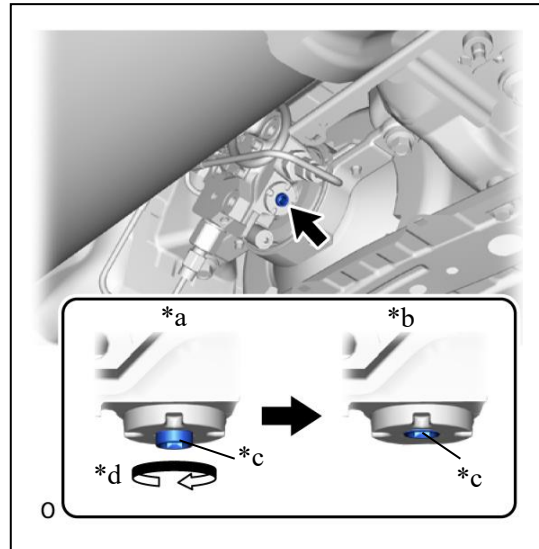

*a	Manual Valve Open
*b	Manual Valve Closed
*c	Adjustment Bolt
*d	Clockwise

- c. Using an 8 mm hexagon socket wrench, rotate the adjustment bolt clockwise to close the manual valve of the No. 2 hydrogen tank assembly.

Torque:

25 N*m (255 kgf*cm, 18 ft.*lbf)

Notice:

The manual valve shuts off the pressure from the hydrogen tank assembly, so be careful not to damage the hexagonal portion.

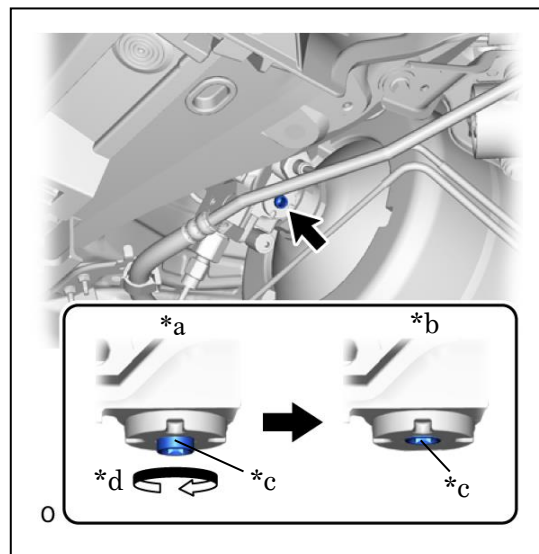

*a	Manual Valve Open
*b	Manual Valve Closed
*c	Adjustment Bolt
*d	Clockwise

- d. for 3 Hydrogen Tank:
Using an 8 mm hexagon socket wrench, rotate the adjustment bolt clockwise to close the manual valve of the No. 3 hydrogen tank assembly.

Torque:

25 N*m (255 kgf*cm, 18 ft.*lbf)

Notice:

The manual valve shuts off the pressure from the hydrogen tank assembly, so be careful not to damage the hexagonal portion.

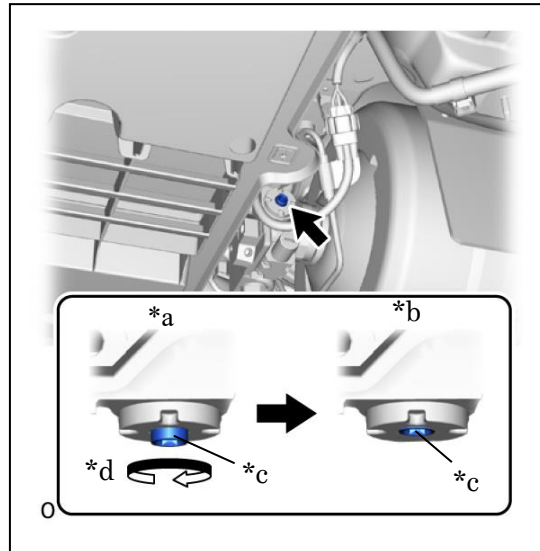

*a	Manual Valve Open
*b	Manual Valve Closed
*c	Adjustment Bolt
*d	Clockwise

- e. Before starting the depressurization procedure, first check that there is no mud or other contaminant around the medium pressure leak check port of the hydrogen supply regulator, and clean it as necessary.

Hint:

Installing the No. 1 hydrogen supply regulator plug while any foreign matter adheres to it can cause a hydrogen gas leak.

f. Perform depressurization.

(1) for 3 Hydrogen Tank:

Make sure that the manual valves of the No. 1 hydrogen tank assembly, No. 2 hydrogen tank assembly and No. 3 hydrogen tank assembly are closed.

(2) for 2 Hydrogen Tank:

Make sure that the manual valves of the No. 1 hydrogen tank assembly and No. 2 hydrogen tank assembly are closed.

- (3) Slowly loosen the No. 1 hydrogen supply regulator plug until the hissing sound of gas escaping can be heard, then stop loosening the No. 1 hydrogen supply regulator plug and wait for the sound to stop. Repeat this procedure multiple times until the sound stops occurring, in order to depressurize the compressed hydrogen gas from the medium pressure leak check port of the hydrogen supply regulator.

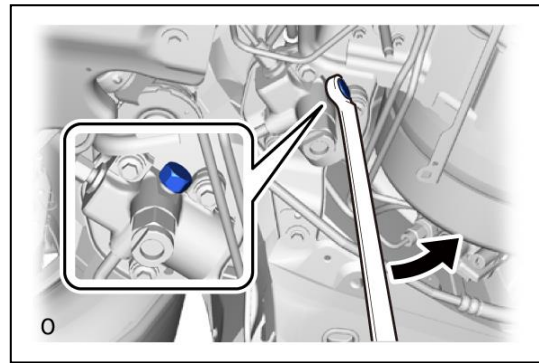

Caution:

- Do not perform depressurization procedures when the manual valve of the hydrogen tank assembly is open.
- The highly pressurized hydrogen gas inside the hydrogen tank assembly could blow out, resulting in a serious accident.

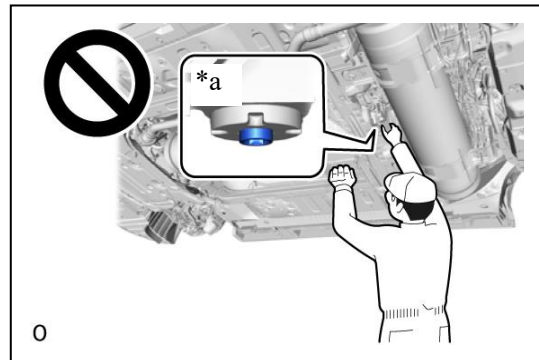

*a	Manual Valve Open
----	-------------------

- When performing depressurization, do not perform procedures by hand without wearing protective glasses and gloves.
- The highly pressurized hydrogen gas inside the hydrogen tank assembly could blow out, resulting in a serious accident.

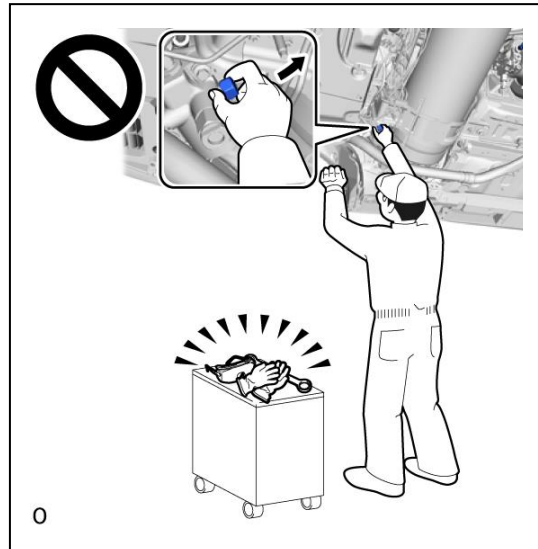

Notice:

When performing depressurization, only loosen the No. 1 hydrogen supply regulator plug. Do not remove it.

- g. Blow compressed air at the underside of the vehicle to disperse any accumulated hydrogen gas.

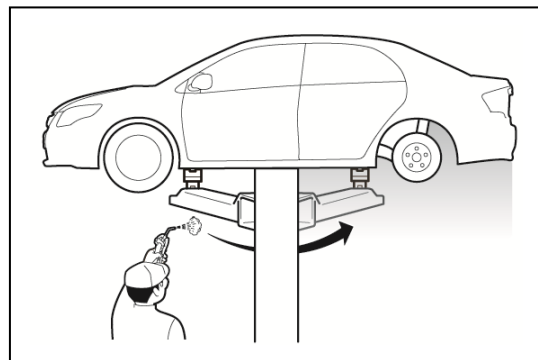

- h. Remove the No. 1 hydrogen supply regulator plug from the hydrogen supply regulator.

Notice:

When frost has formed on the hydrogen tank assembly or piping, water droplets may be formed when the frost begins to melt. If water droplets enter the tank or piping, it could result in blockage of the hydrogen piping, so do not allow water droplets to enter the tank or piping.

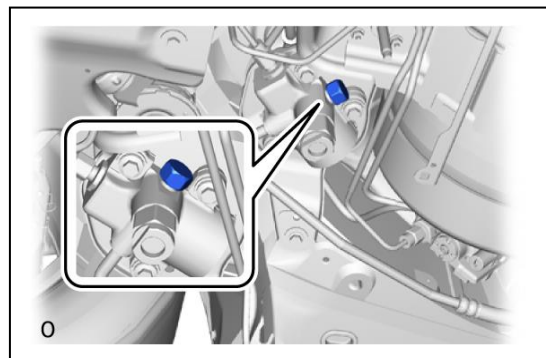

- i. Remove the O-ring from the hydrogen supply regulator.

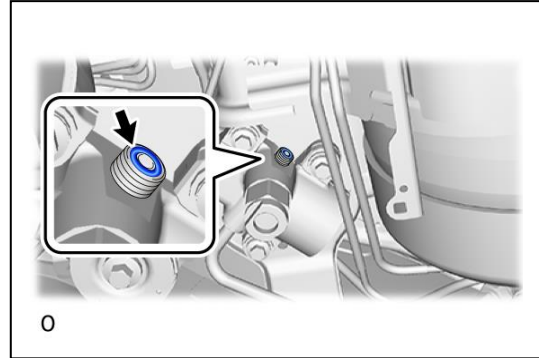

- j. To prevent damage to the seal portions and threaded portions, and to prevent foreign matter such as dust or metal fragments from entering the openings, cover the seal portions, threaded portions, and openings of the hydrogen supply regulator with protective tape.

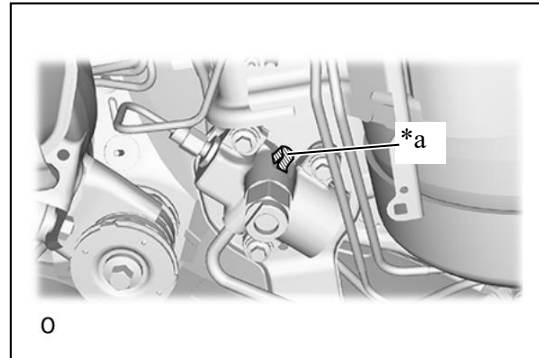

*a	Protective Tape
----	-----------------

- k. To prevent damage to the seal portions and threaded portions, and to prevent foreign matter such as dust or metal fragments from entering the openings, do not remove the protective tape covering the seal portions, threaded portions, and openings of the hydrogen supply regulator until immediately before performing work.

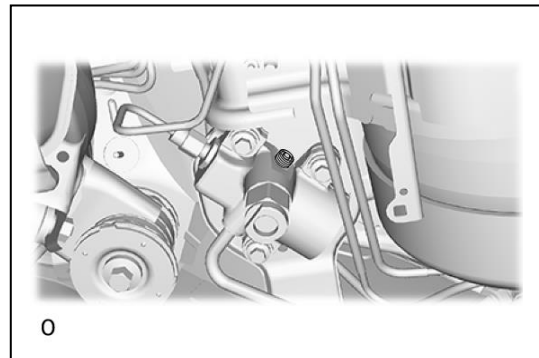

Notice:

When frost has formed on the hydrogen tank assembly or piping, water droplets may be formed when the frost begins to melt. If water droplets enter the tank or piping, it could result in blockage of the hydrogen piping, so do not allow water droplets to enter the tank or piping.

- l. Apply TOYOTA Genuine FC Grease to a new O-ring and to the threaded portion of the hydrogen supply regulator.

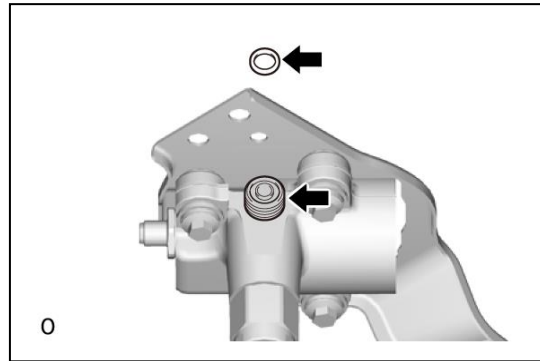

- m. Install the O-ring to the hydrogen supply regulator.

Notice:

During installation, make sure not to damage the O-ring.

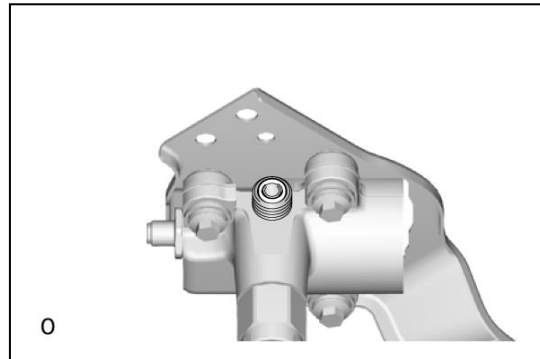

n. Connect SST (hydrogen venting tool).

SST

09404-62010 (09404-06010, 09404-06020, 09404-06030, 09404-06040, 09404-06050)

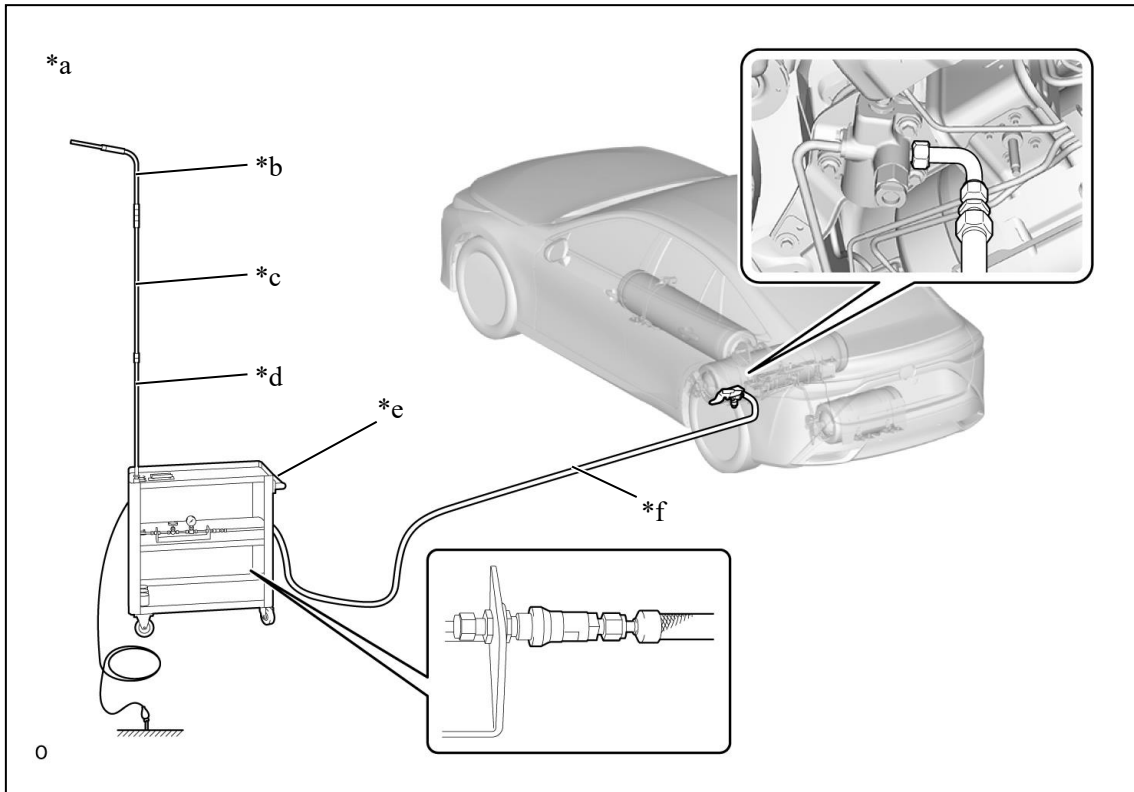

*a	Concept of SST (hydrogen venting tool) Connection	*b	SST (Upper Release Pipe)
*c	SST (Middle Release Pipe)	*d	SST (Lower Release Pipe)
*e	SST (Venting Stand)	*f	SST (Flexible Hose)

Hint:

There are 2 types of SST (flexible hose).

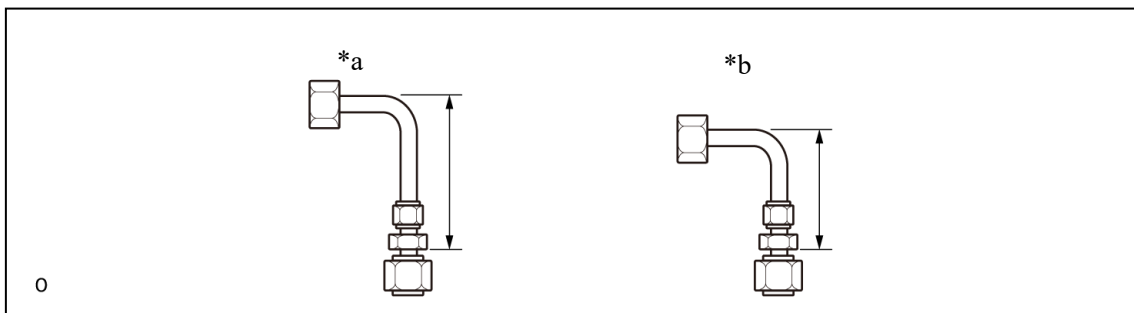

*a	Type A	*b	Type B
----	--------	----	--------

o. for Type A:

- (1) Temporarily install SST (flexible hose) to the hydrogen supply regulator.

SST

09404-62010 (09404-06020)

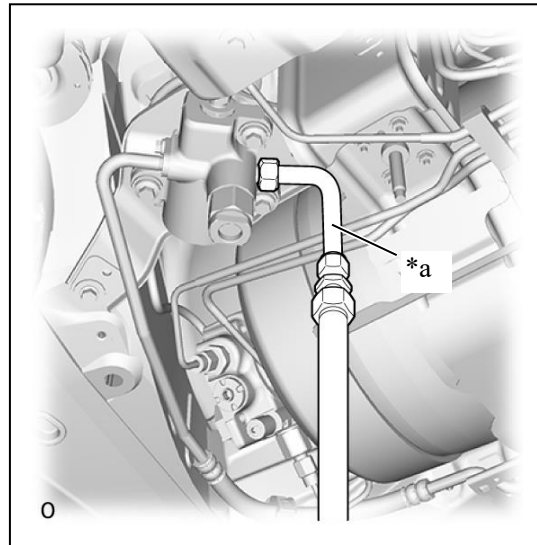

*a	SST (Flexible Hose)
----	---------------------

- (2) Using SST(open end wrench), tighten SST (flexible hose).

SST

09404-62010 (09404-06020) 09922-10240

Torque:

Specified tightening torque

9.0 N*m (92 kgf*cm, 80 in.*lbf)

Notice:

- Make sure that SST (flexible hose) does not interfere with part of the vehicle.
- If SST (flexible hose) interferes with any part of the vehicle, protect it with a piece of cloth, etc.

Hint:

- Calculate the torque wrench reading when changing the fulcrum length of the torque wrench.
- When using SST (fulcrum length of 40 mm (1.57 in.)) + torque wrench (fulcrum length of 162 mm (6.38 in.)): 7.2 N*m (73 kgf*cm, 64 in.*lbf)

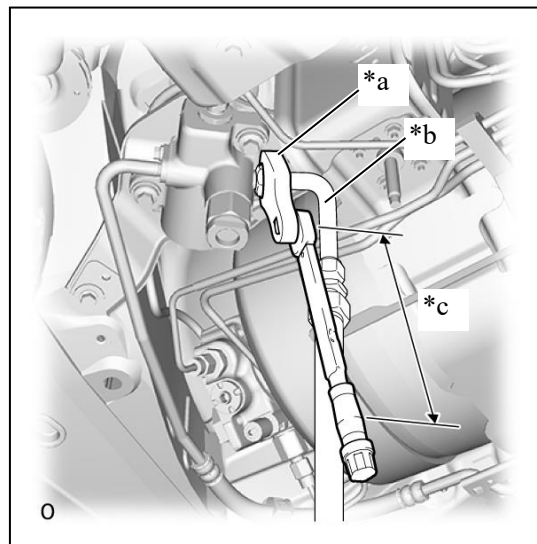

*a	SST (Open End Wrench)
*b	SST (Flexible Hose)
*c	Specified tightening torque

- (3) Connect SST (flexible hose) to SST (Venting Stand).

SST

09404-62010 (09404-06010, 09404-06020)

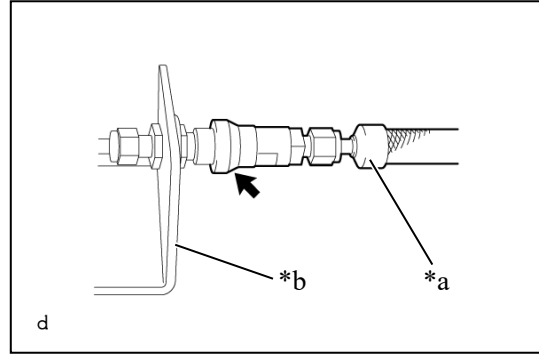

*a	SST (Flexible Hose)
*b	SST (Venting Stand)

p. for Type B:

- (1) Remove the 3 bolts of the hydrogen supply regulator.

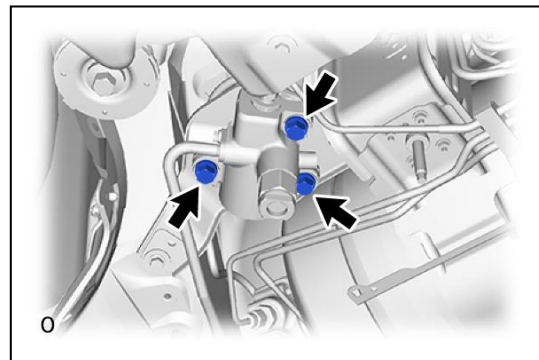

- (2) Temporarily install SST (flexible hose) to the hydrogen supply regulator.

SST

09404-62010 (09404-06020)

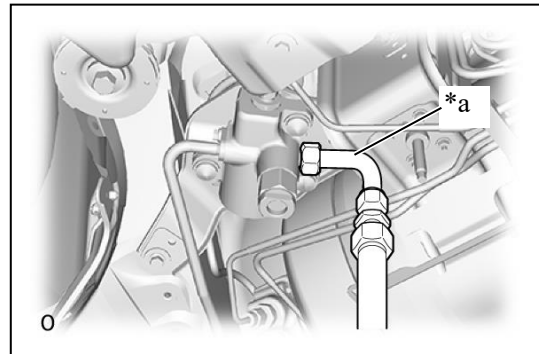

*a	SST (Flexible Hose)
----	---------------------

- (3) Install the hydrogen supply regulator with the 3 bolts.

Torque:

16.5 N*m (168 kgf*cm, 12 ft.*lbf)

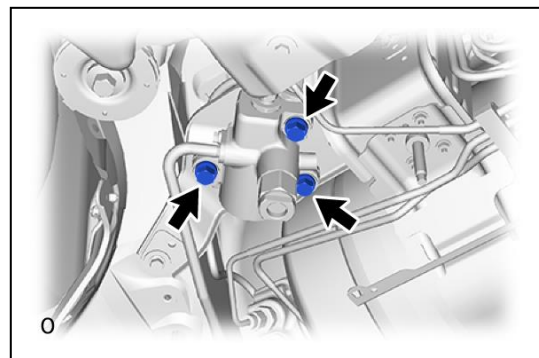

(4) Using SST(open end wrench), tighten SST (flexible hose).

SST

09404-62010 (09404-06020) 09922-10240

Torque:

Specified tightening torque

9.0 N*m (92 kgf*cm, 80 in.*lbf)

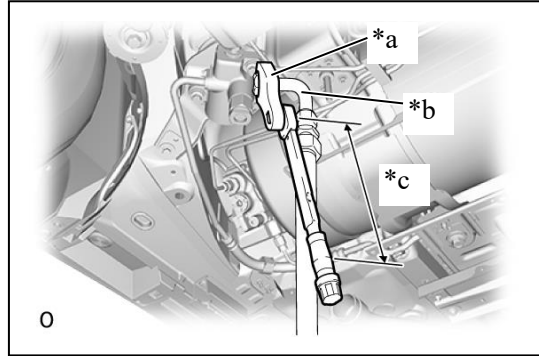

*a	SST (Open End Wrench)
*b	SST (Flexible Hose)
*c	Specified tightening torque

Notice:

- Make sure that SST (flexible hose) does not interfere with part of the vehicle.
- If SST (flexible hose) interferes with any part of the vehicle, protect it with a piece of cloth, etc.

Hint:

- Calculate the torque wrench reading when changing the fulcrum length of the torque wrench.
- When using SST (fulcrum length of 40 mm (1.57 in.)) + torque wrench (fulcrum length of 162 mm (6.38 in.)): 7.2 N*m (73 kgf*cm, 64 in.*lbf)

(5) Connect SST (flexible hose) to SST (Venting Stand).

SST

09404-62010 (09404-06010, 09404-06020)

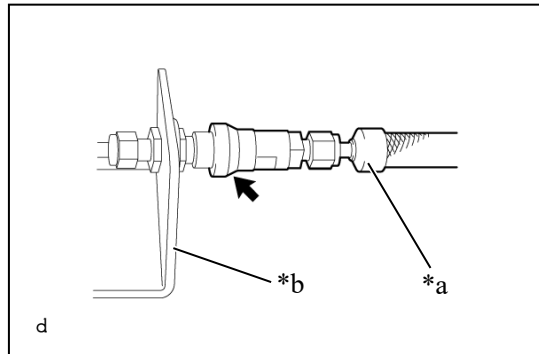

*a	SST (Flexible Hose)
*b	SST (Venting Stand)

q. Under basic conditions

(1) Set SST (hydrogen venting tool) in an outdoor location.

Notice:

Take care that the compressed hydrogen gas that is discharged during the discharging procedure does not enter any indoor location.

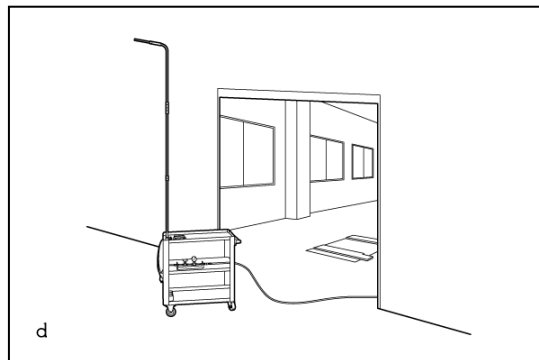

r. Other than basic conditions (when outdoor setup is not possible)

- (1) When SST (hydrogen venting tool) will be set up indoors, locate it along a wall near a window, and with the tip of SST (upper release pipe) outdoors.

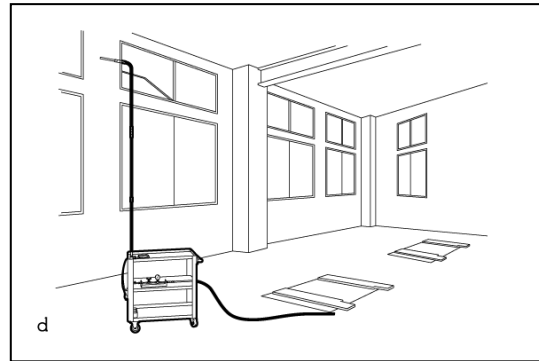

Notice:

Open windows on two sides or more, and ensure that there is adequate ventilation to prevent the compressed hydrogen gas that is discharged from collecting inside.

s. for 3 Hydrogen Tank:

Open the tank shut valves of the No. 1 hydrogen tank assembly, No. 2 hydrogen tank assembly No. 3 hydrogen tank assembly, and after 2 to 3 seconds, close the tank shut valves again.

Caution:

- When opening the tank shut valve and applying pressure to SST (hydrogen venting tool), stay away from SST (flexible hose).
- If SST (flexible hose) comes off, you could be struck by the loose end of SST (flexible hose), causing a serious accident.

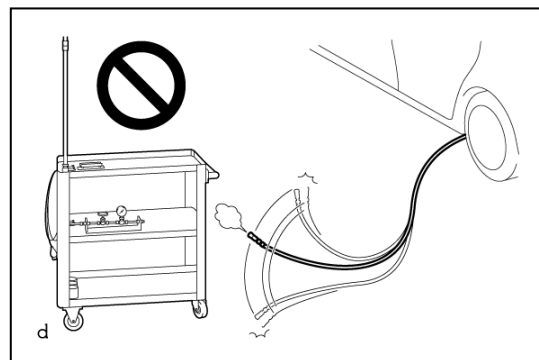

Notice:

If the Data List item "Medium-range Hydrogen Pressure (gauge)" decreases to below 0.7 MPa (7.1 kgf/cm², 102 psi) the tank shut valves of the No. 1 hydrogen tank assembly, No. 2 hydrogen tank assembly and No. 3 hydrogen tank assembly will forcibly close.

t. for 2 Hydrogen Tank:

Open the tank shut valves of the No. 1 hydrogen tank assembly and No. 2 hydrogen tank assembly, and after 2 to 3 seconds, close the tank shut valves again.

Caution:

- **When opening the tank shut valve and applying pressure to SST (hydrogen venting tool), stay away from SST (flexible hose).**
- **If SST (flexible hose) comes off, you could be struck by the loose end of SST (flexible hose), causing a serious accident.**

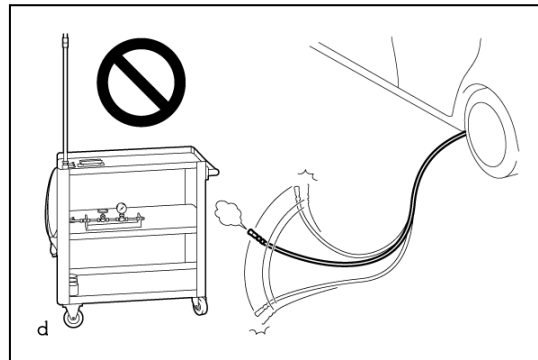

Notice:

If the Data List item "Medium-range Hydrogen Pressure (gauge)" decreases to below 0.7 MPa (7.1 kgf/cm², 102 psi) the tank shut valves of the No. 1 hydrogen tank assembly and No. 2 hydrogen tank assembly will forcibly close.

u. for 3 Hydrogen Tank:

If the tank shut valves of the No. 1 hydrogen tank assembly, No. 2 hydrogen tank assembly and No. 3 hydrogen tank assembly do not open, open the tank shut valves again, and after 2 to 3 seconds, close the tank shut valves.

v. for 2 Hydrogen Tank:

If the tank shut valves of the No. 1 hydrogen tank assembly and No. 2 hydrogen tank assembly do not open, open the tank shut valves again, and after 2 to 3 seconds, close the tank shut valves.

w. Perform preliminary leak check (using remaining piping pressure).

Hint:

Perform leak check using the pressure remaining upstream of the tank shut valve.

- (1) If there are any water droplets, etc. adhering to the measurement locations, wipe them away before performing the procedure.

Notice:

Performing the measurement while any water droplets, etc. are adhering could damage the hydrogen gas detector.

(2) Using SST and a hydrogen gas detector, inspect for leaks in the locations shown in the illustration.

SST

09401-62020

Specified Value:

Less than 500 ppm

Notice:

If any values are outside the specified range, disconnect those locations that have leaks and assemble the parts again.

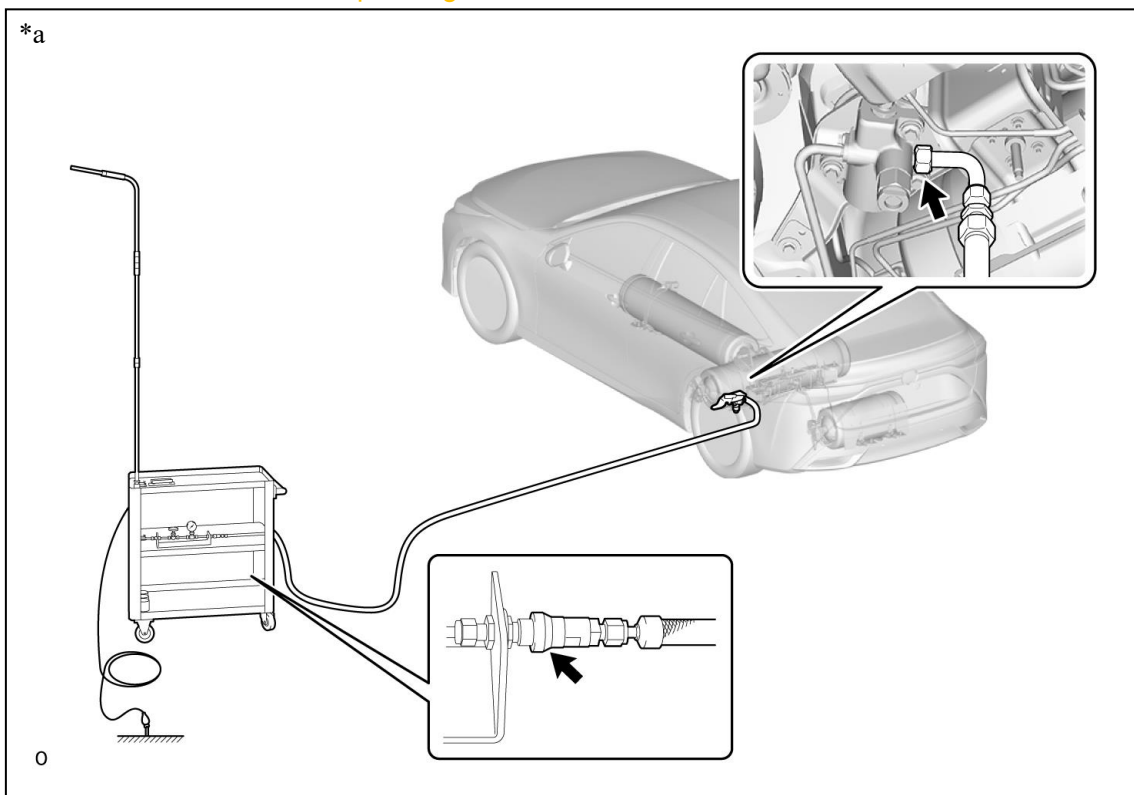

*a	Locations to Check for Leaks	-	-
	Leak Check Location	-	-

- x. Using an 8 mm socket hexagon wrench, rotate the adjustment bolt counterclockwise, and open the No. 1 hydrogen tank assembly manual valve.

Notice:

- The manual valve shuts off the pressure from the hydrogen tank assembly, so be careful not to damage the hexagonal portion.
- If the hexagonal portion is damaged, it will be impossible to operate the adjustment bolt
- Do not rotate the adjustment bolt more than 4 rotations.
- Rotating the adjustment bolt more than 4 rotations could damage the manual valve.

Hint:

When the manual valve is opened, the protrusion of the adjustment bolt is 3.5 mm (0.138 in.) or less.

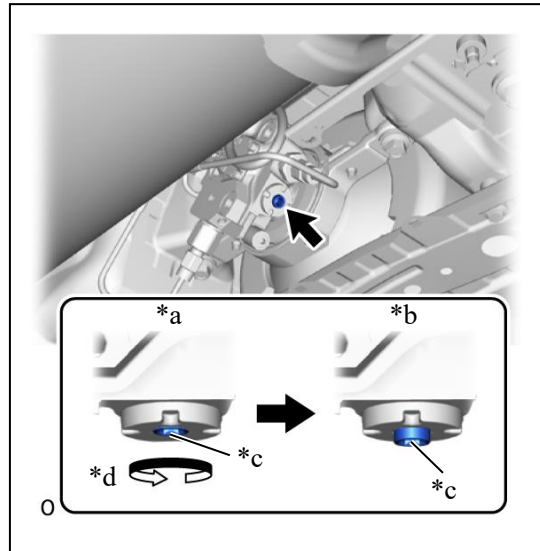

*a	Manual Valve Closed
*b	Manual Valve Open
*c	Adjustment Bolt
*d	Counterclockwise

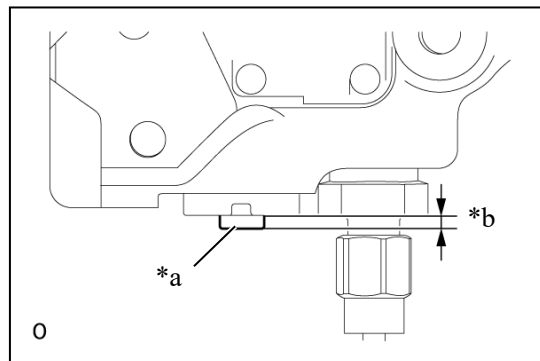

*a	Adjustment Bolt
*b	Protrusion

- y. Using an 8 mm socket hexagon wrench, rotate the adjustment bolt counterclockwise, and open the No. 2 hydrogen tank assembly manual valve.

Notice:

- The manual valve shuts off the pressure from the hydrogen tank assembly, so be careful not to damage the hexagonal portion.
- If the hexagonal portion is damaged, it will be impossible to operate the adjustment bolt
- Do not rotate the adjustment bolt more than 4 rotations.
- Rotating the adjustment bolt more than 4 rotations could damage the manual valve.

Hint:

When the manual valve is opened, the protrusion of the adjustment bolt is 3.5 mm (0.138 in.) or less.

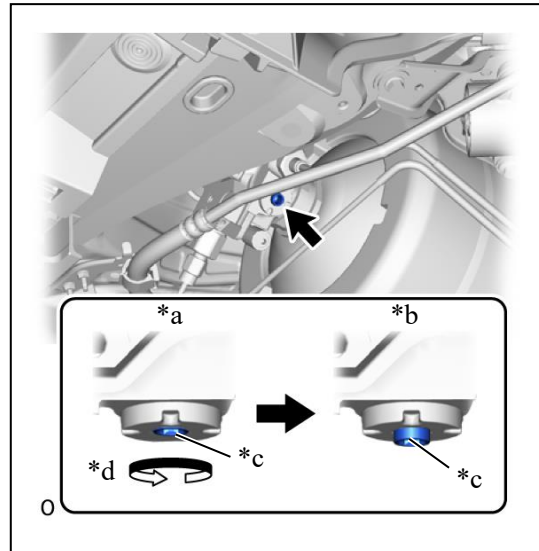

*a	Manual Valve Closed
*b	Manual Valve Open
*c	Adjustment Bolt
*d	Counterclockwise

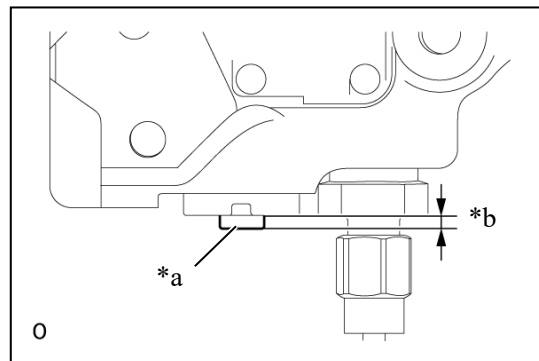

*a	Adjustment Bolt
*b	Protrusion

- z. for 3 Hydrogen Tank:
Using an 8 mm socket hexagon wrench, rotate the adjustment bolt counterclockwise, and open the No. 3 hydrogen tank assembly manual valve.

Notice:

- The manual valve shuts off the pressure from the hydrogen tank assembly, so be careful not to damage the hexagonal portion.
- If the hexagonal portion is damaged, it will be impossible to operate the adjustment bolt
- Do not rotate the adjustment bolt more than 4 rotations.
- Rotating the adjustment bolt more than 4 rotations could damage the manual valve.

Hint:

When the manual valve is opened, the protrusion of the adjustment bolt is 3.5 mm (0.138 in.) or less.

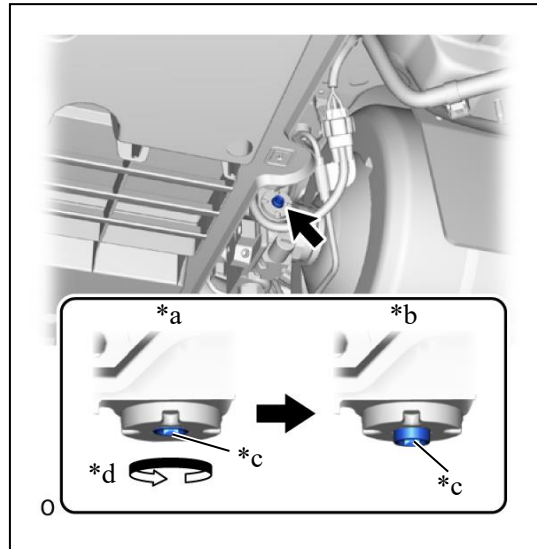

*a	Manual Valve Closed
*b	Manual Valve Open
*c	Adjustment Bolt
*d	Counterclockwise

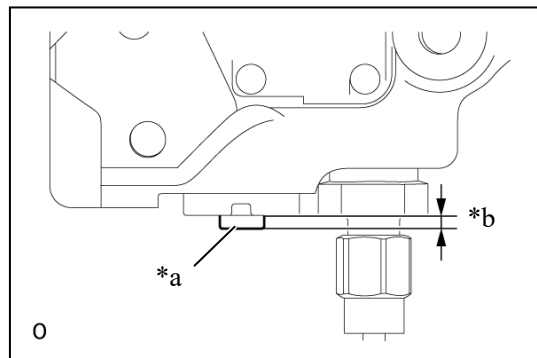

*a	Adjustment Bolt
*b	Protrusion

aa. for 3 Hydrogen Tank:

Open the tank shut valves of the No. 1 hydrogen tank assembly, No. 2 hydrogen tank assembly No. 3 hydrogen tank assembly, and after 2 to 3 seconds, close the tank shut valves again.

Caution:

- When opening the tank shut valve and applying pressure to SST (hydrogen venting tool), stay away from SST (flexible hose).
- If SST (flexible hose) comes off, you could be struck by the loose end of SST (flexible hose), causing a serious accident.

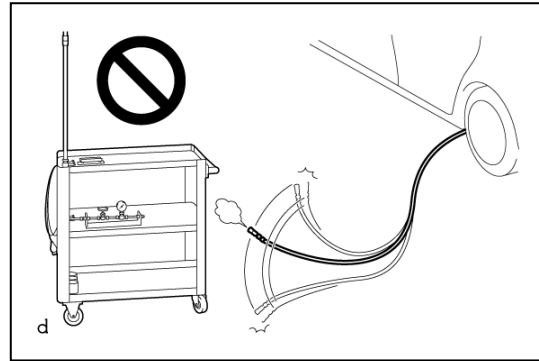

Notice:

If the Data List item "Medium-range Hydrogen Pressure (gauge)" decreases to below 0.7 MPa (7.1 kgf/cm², 102 psi) the tank shut valves of the No. 1 hydrogen tank assembly, No. 2 hydrogen tank assembly and No. 3 hydrogen tank assembly will forcibly close.

bb. for 2 Hydrogen Tank:

Open the tank shut valves of the No. 1 hydrogen tank assembly and No. 2 hydrogen tank assembly, and after 2 to 3 seconds, close the tank shut valves again.

Caution:

- When opening the tank shut valve and applying pressure to SST (hydrogen venting tool), stay away from SST (flexible hose).
- If SST (flexible hose) comes off, you could be struck by the loose end of SST (flexible hose), causing a serious accident.

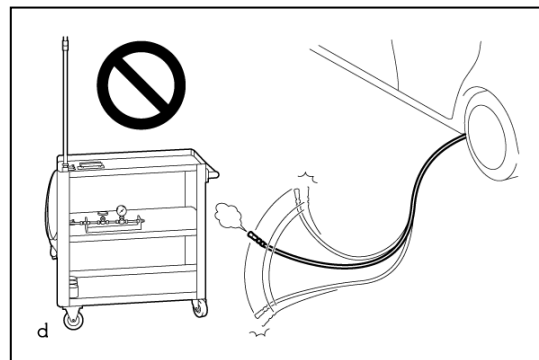

Notice:

If the Data List item "Medium-range Hydrogen Pressure (gauge)" decreases to below 0.7 MPa (7.1 kgf/cm², 102 psi) the tank shut valves of the No. 1 hydrogen tank assembly and No. 2 hydrogen tank assembly will forcibly close.

cc. for 3 Hydrogen Tank:

If the tank shut valves of the No. 1 hydrogen tank assembly, No. 2 hydrogen tank assembly and No. 3 hydrogen tank assembly do not open, open the tank shut valves again, and after 2 to 3 seconds, close the tank shut valves.

dd. for 2 Hydrogen Tank:

If the tank shut valves of the No. 1 hydrogen tank assembly and No. 2 hydrogen tank assembly do not open, open the tank shut valves again, and after 2 to 3 seconds, close the tank shut valves.

ee. Perform preliminary leak check (using tank pressure)

Hint:

Perform leak check while applying hydrogen tank pressure.

(1) Using SST and a hydrogen gas detector, inspect for leaks in the locations shown in the illustration.

SST

09401-62020

Specified Value:

Less than 500 ppm

Notice:

- If any values are outside the specified range, disconnect those locations that have leaks and assemble the parts again.
- After reassembling the locations that were leaking, perform the leak check again.

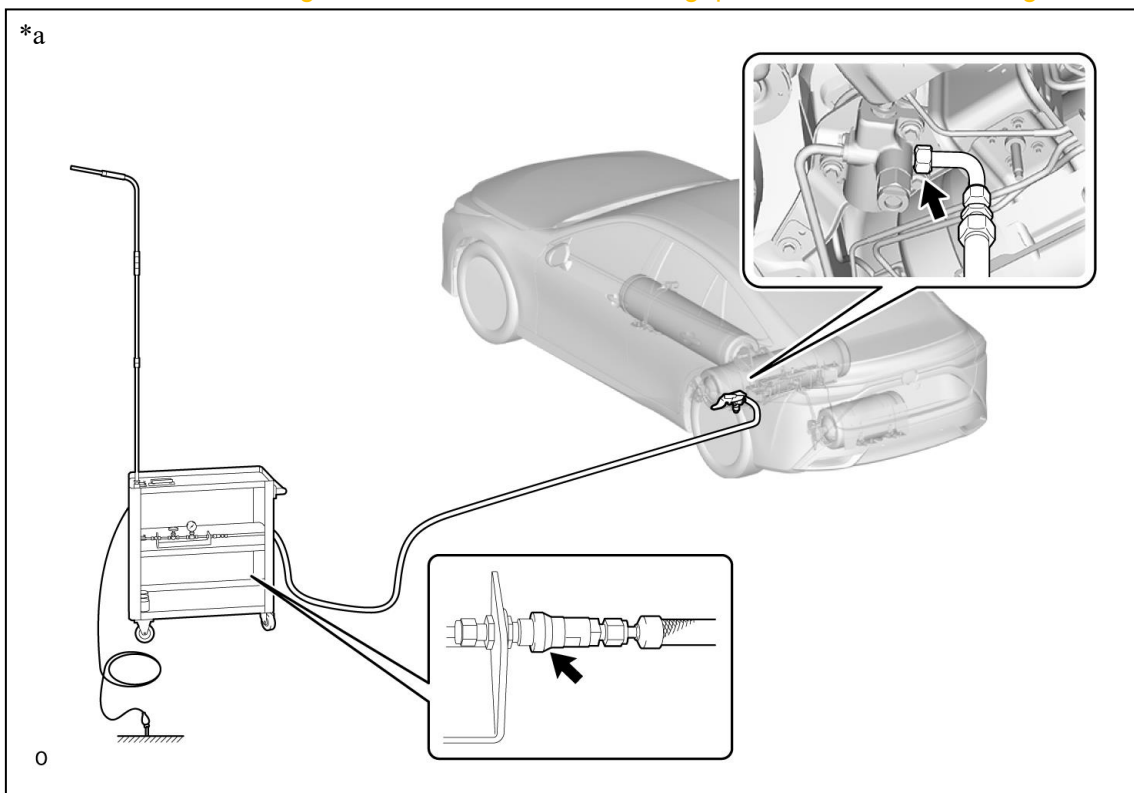

*a	Locations to Check for Leaks	-	-
	Leak Check Location	-	-

9. DRAIN COMPRESSED HYDROGEN GAS

Caution:

- While discharging pressurized hydrogen gas, the temperature inside the tank decreases and frost may form on the outside. Do not touch tanks, piping, or SST (hydrogen venting tool) when frost has formed on them.
- Touching tanks, piping, or SST (hydrogen venting tool) on which frost has formed could result in burn-like injuries due to frostbite.

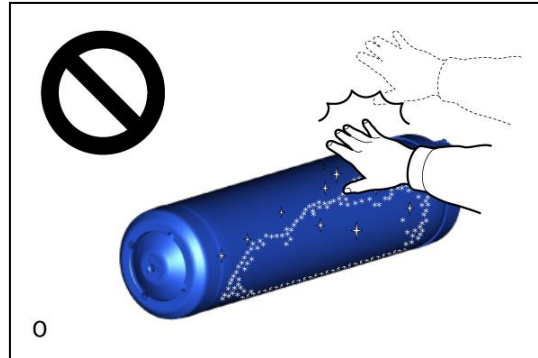

Notice:

- Starting the discharging of compressed hydrogen gas will cause the temperature inside the hydrogen gas lines to decrease.
- To protect the hydrogen tank and related components, when the hydrogen gas temperature becomes $-30\text{ }^{\circ}\text{C}$ ($-86\text{ }^{\circ}\text{F}$) or less, the discharging of compressed hydrogen gas must be stopped temporarily.
- for 3 Hydrogen Tank:
Monitor the Data List items "Hydrogen Tank 1 Temperature (Filtered Value)", "Hydrogen Tank 2 Temperature (Filtered Value)" and "Hydrogen Tank 3 Temperature (Filtered Value)" while performing compressed hydrogen gas discharging.
- for 2 Hydrogen Tank:
Monitor the Data List items "Hydrogen Tank 1 Temperature (Filtered Value)" and "Hydrogen Tank 2 Temperature (Filtered Value)" while performing compressed hydrogen gas discharging.
- While performing compressed hydrogen gas discharging, periodically conduct leak checks of each connecting part of SST (hydrogen venting tool).
- If a leak is found, stop the discharging procedure.

Hint:

<Approximate Discharging Times for Compressed Hydrogen Gas>

Hydrogen Gas Pressure	Discharging Time (approximate)
70 MPa (713.8 kgf/cm ² , 10150 psi)	210 minutes
55 MPa (560.8 kgf/cm ² , 7975 psi)	175 minutes
35 MPa (356.9 kgf/cm ² , 5075 psi)	130 minutes

- The times listed above are only approximations, and times will vary depending on the actual work environment (ambient temperature, hydrogen tank gas temperature, etc.)
- • The (approximate) times listed above do not include time spent while the procedure is halted due to hydrogen gas temperature becoming too low.

- Lower the vehicle on the lift.
- Connect a charger to the auxiliary battery and put the auxiliary battery into a charging state.

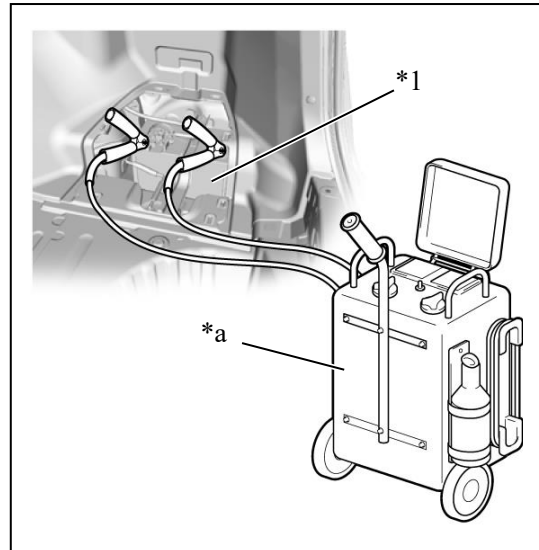

*1	Auxiliary Battery
*a	Battery Charger

- Using the GTS, enter the following menus: Body Electrical / Power Source Control / Utility / Auto Power OFF Cancel

Body Electrical > Power Source Control >Utility

Tester Display
Auto Power OFF Cancel

d. for 3 Hydrogen Tank:

Using the GTS, enter the following menus: Powertrain / EV / Data List / High-Range Hydrogen Pressure (Filtered Value), Medium-Range Hydrogen Pressure (Filtered Value), Tank Area 1 Hydrogen Density, Tank Area 2 Hydrogen Density, Hydrogen Tank 1 Temperature (Filtered Value), Hydrogen Tank 2 Temperature (Filtered Value), Hydrogen Tank 3 Temperature (Filtered Value)

Powertrain > EV > Data List

Tester Display
High-Range Hydrogen Pressure (Filtered Value)
Medium-Range Hydrogen Pressure (Filtered Value)
Tank Area 1 Hydrogen Density
Tank Area 2 Hydrogen Density
Hydrogen Tank 1 Temperature (Filtered Value)
Hydrogen Tank 2 Temperature (Filtered Value)
Hydrogen Tank 3 Temperature (Filtered Value)

Hint:

If the GTS unit setting is absolute pressure (abs), change it to gauge pressure (gauge).

e. for 2 Hydrogen Tank:

Using the GTS, enter the following menus: Powertrain / EV / Data List / High-Range Hydrogen Pressure (Filtered Value), Medium-Range Hydrogen Pressure (Filtered Value), Tank Area 1 Hydrogen Density, Tank Area 2 Hydrogen Density, Hydrogen Tank 1 Temperature (Filtered Value), Hydrogen Tank 2 Temperature (Filtered Value)

Powertrain > EV > Data List

Tester Display
High-Range Hydrogen Pressure (Filtered Value)
Medium-Range Hydrogen Pressure (Filtered Value)
Tank Area 1 Hydrogen Density
Tank Area 2 Hydrogen Density
Hydrogen Tank 1 Temperature (Filtered Value)
Hydrogen Tank 2 Temperature (Filtered Value)

Hint:

If the GTS unit setting is absolute pressure (abs), change it to gauge pressure (gauge).

f. for 3 Hydrogen Tank:

Open the tank shut valves of the No. 1 hydrogen tank assembly, No. 2 hydrogen tank assembly and No. 3 hydrogen tank assembly.

Notice:

If the Data List item "Medium-range Hydrogen Pressure (gauge)" decreases to below 0.7 MPa (7.1 kgf/cm², 102 psi) the tank shut valves of the No. 1 hydrogen tank assembly, No. 2 hydrogen tank assembly and No. 3 hydrogen tank assembly will forcibly close.

g. for 2 Hydrogen Tank:

Open the tank shut valves of the No. 1 hydrogen tank assembly and No. 2 hydrogen tank assembly.

Notice:

If the Data List item "Medium-range Hydrogen Pressure (gauge)" decreases to below 0.7 MPa (7.1 kgf/cm², 102 psi) the tank shut valves of the No. 1 hydrogen tank assembly and No. 2 hydrogen tank assembly will forcibly close.

h. for 3 Hydrogen Tank:

If the tank shut valves of the No. 1 hydrogen tank assembly, No. 2 hydrogen tank assembly and No. 3 hydrogen tank assembly do not open, open the tank shut valves again.

i. for 2 Hydrogen Tank:

If the tank shut valves of the No. 1 hydrogen tank assembly and No. 2 hydrogen tank assembly do not open, open the tank shut valves again.

- j. Open the open/close valve of SST (venting stand), and discharge compressed hydrogen gas.

SST

09404-62010 (09404-06010)

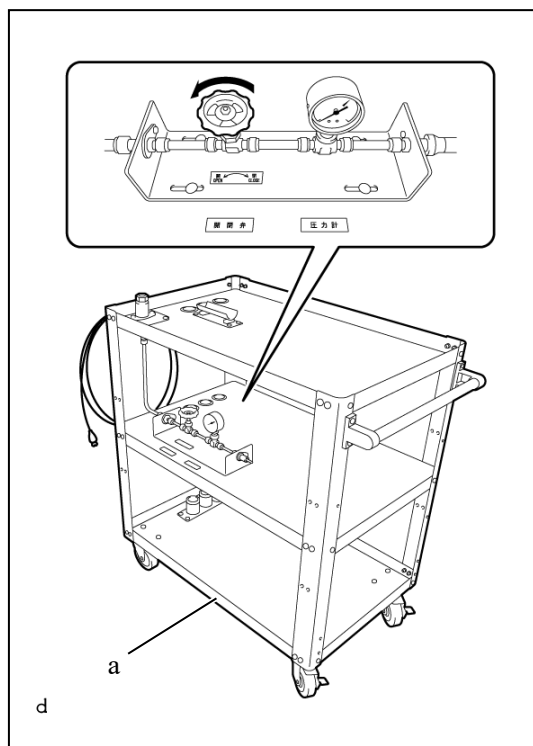

*a	SST (Venting Stand)
----	---------------------

- k. for 3 Hydrogen Tank:

Read the Data List and check that "Hydrogen Tank 1 Temperature (Filter Value)", "Hydrogen Tank 2 Temperature (Filter Value)" and "Hydrogen Tank 3 Temperature (Filter Value)" begin to decrease together.

Hint:

- By checking that the hydrogen tank temperatures are decreasing, it can be determined that the compressed hydrogen gas is discharging.
- If either one of "Hydrogen Tank 1 Temperature (Filter Value)", "Hydrogen Tank 2 Temperature (Filter Value)" and "Hydrogen Tank 3 Temperature (Filter Value)" does not decrease, perform the following procedure.

- (a) Close the open/close valve of SST (venting stand).

Notice:

To protect the tank shut valve, make sure to first close the open/close valve of SST (venting stand).

- (b) Close the tank shut valves of the No. 1 hydrogen tank assembly, No. 2 hydrogen tank assembly and No. 3 hydrogen tank assembly.

(c) For the side where the hydrogen gas temperature does not decrease, check that the manual valve is open, and if it is closed, open the manual valve.

(d) Open the tank shut valves of the No. 1 hydrogen tank assembly, No. 2 hydrogen tank assembly and No. 3 hydrogen tank assembly.

Notice:

If the Data List item "Medium-range Hydrogen Pressure (gauge)" decreases to below 0.7 MPa (7.1 kgf/cm², 102 psi) the tank shut valves of the No. 1 hydrogen tank assembly, No. 2 hydrogen tank assembly and No. 3 hydrogen tank assembly will forcibly close.

(e) If the tank shut valves of the No. 1 hydrogen tank assembly, No. 2 hydrogen tank assembly and No. 3 hydrogen tank assembly do not open, open the tank shut valves again.

(f) Open the open/close valve of SST (venting stand) again, and discharge the compressed hydrogen gas.

1. for 2 Hydrogen Tank:

Read the Data List and check that "Hydrogen Tank 1 Temperature (Filter Value)" and "Hydrogen Tank 2 Temperature (Filter Value)" begin to decrease together.

Hint:

- By checking that the hydrogen tank temperatures are decreasing, it can be determined that the compressed hydrogen gas is discharging.
- If either one of "Hydrogen Tank 1 Temperature (Filter Value)" and "Hydrogen Tank 2 Temperature (Filter Value)" does not decrease, perform the following procedure.

(a) Close the open/close valve of SST (venting stand).

Notice:

To protect the tank shut valve, make sure to first close the open/close valve of SST (venting stand).

(b) Close the tank shut valves of the No. 1 hydrogen tank assembly and No. 2 hydrogen tank assembly.

(c) For the side where the hydrogen gas temperature does not decrease, check that the manual valve is open, and if it is closed, open the manual valve.

(d) Open the tank shut valves of the No. 1 hydrogen tank assembly and No. 2 hydrogen tank assembly.

Notice:

If the Data List item "Medium-range Hydrogen Pressure (gauge)" decreases to below 0.7 MPa (7.1 kgf/cm², 102 psi) the tank shut valves of the No. 1 hydrogen tank assembly and No. 2 hydrogen tank assembly will forcibly close.

(e) If the tank shut valves of the No. 1 hydrogen tank assembly and No. 2 hydrogen tank assembly do not open, open the tank shut valves again.

(f) Open the open/close valve of SST (venting stand) again, and discharge the compressed hydrogen gas.

m. for 3 Hydrogen Tank:

Read the Data List, and if either of the items "Hydrogen Tank 1 Temperature (Filter Value)", "Hydrogen Tank 2 Temperature (Filter Value)" or "Hydrogen Tank 3 Temperature (Filter Value)" have become -30 °C (-86 °F) or less:

(1) Close the open/close valve of SST (venting stand) [*1]

Notice:

To protect the tank shut valve, make sure to first close the open/close valve of SST (venting stand).

(2) Close the tank shut valves of the No. 1 hydrogen tank assembly, No. 2 hydrogen tank assembly and No. 3 hydrogen tank assembly.[*2]

(3) Wait until both values "Hydrogen Tank 1 Temperature (Filter Value)", "Hydrogen Tank 2 Temperature (Filter Value)" and "Hydrogen Tank 3 Temperature (Filter Value)" have increased to -20 °C (-68 °F) or more.[*3]

- (4) Open the tank shut valves of the No. 1 hydrogen tank assembly, No. 2 hydrogen tank assembly and No. 3 hydrogen tank assembly.[*4]

Notice:

If the Data List item "Medium-range Hydrogen Pressure (gauge)" decreases to below 0.7 MPa (7.1 kgf/cm², 102 psi) the tank shut valves of the No. 1 hydrogen tank assembly, No. 2 hydrogen tank assembly and No. 3 hydrogen tank assembly will forcibly close.

- (5) If the tank shut valves of the No. 1 hydrogen tank assembly, No. 2 hydrogen tank assembly and No. 3 hydrogen tank assembly do not open, open the tank shut valves again.[*5]

- (6) Open the open/close valve of SST (venting stand) and discharge compressed hydrogen gas again.[*6]

Notice:

During the compressed hydrogen gas discharging procedure, if it appears that either "Hydrogen Tank 1 Temperature (Filter Value)", "Hydrogen Tank 2 Temperature (Filter Value)" or "Hydrogen Tank 3 Temperature (Filter Value)" are about to decrease to -30 °C (-86 °F) or less, repeat steps [*1] through [*6].

n. for 2 Hydrogen Tank:

Read the Data List, and if either of the items "Hydrogen Tank 1 Temperature (Filter Value)" or "Hydrogen Tank 2 Temperature (Filter Value)" have become -30 °C (-86 °F) or less:

- (1) Close the open/close valve of SST (venting stand) [*1]

Notice:

To protect the tank shut valve, make sure to first close the open/close valve of SST (venting stand).

- (2) Close the tank shut valves of the No. 1 hydrogen tank assembly and No. 2 hydrogen tank assembly.[*2]

- (3) Wait until both values "Hydrogen Tank 1 Temperature (Filter Value)" and "Hydrogen Tank 2 Temperature (Filter Value)" have increased to -20 °C (-68 °F) or more.[*3]

- (4) Open the tank shut valves of the No. 1 hydrogen tank assembly and No. 2 hydrogen tank assembly.[*4]

Notice:

If the Data List item "Medium-range Hydrogen Pressure (gauge)" decreases to below 0.7 MPa (7.1 kgf/cm², 102 psi) the tank shut valves of the No. 1 hydrogen tank assembly, No. 2 hydrogen tank assembly will forcibly close.

- (5) If the tank shut valves of the No. 1 hydrogen tank assembly and No. 2 hydrogen tank assembly do not open, open the tank shut valves again.[*5]

- (6) Open the open/close valve of SST (venting stand) and discharge compressed hydrogen gas again.[*6]

Notice:

During the compressed hydrogen gas discharging procedure, if it appears that either "Hydrogen Tank 1 Temperature (Filter Value)" or "Hydrogen Tank 2 Temperature (Filter Value)" are about to decrease to -30 °C (-86 °F) or less, repeat steps [*1] through [*6].

- o. Continue to monitor the Data List, and when the value of "Medium-range Hydrogen Pressure (gauge)" becomes 0.8 MPa (8.2 kgf/cm², 116 psi), close the open/close valve of SST (venting stand).

Notice:

- To protect the tank shut valve, make sure to first close the open/close valve of SST (venting stand).
- for 3 Hydrogen Tank:
Forgetting to close the open/close valve of SST (venting stand) and allowing the Data List item "Medium-range Hydrogen Pressure (gauge)" to decrease to below 0.7 MPa (7.1 kgf/cm², 102 psi) will cause the tank shut valves of the No. 1 hydrogen tank assembly, No. 2 hydrogen tank assembly and No. 3 hydrogen tank assembly to forcibly close.
- for 2 Hydrogen Tank:
Forgetting to close the open/close valve of SST (venting stand) and allowing the Data List item "Medium-range Hydrogen Pressure (gauge)" to decrease to below 0.7 MPa (7.1 kgf/cm², 102 psi) will cause the tank shut valves of the No. 1 hydrogen tank assembly and No. 2 hydrogen tank assembly to forcibly close.

p. for 3 Hydrogen Tank:

Read the Data List, and if either of the items "Hydrogen Tank 1 Temperature (Filter Value)", "Hydrogen Tank 2 Temperature (Filter Value)" or "Hydrogen Tank 3 Temperature (Filter Value)" have become $-30\text{ }^{\circ}\text{C}$ ($-86\text{ }^{\circ}\text{F}$) or less:

(1) Close the open/close valve of SST (venting stand) [*1]

Notice:

To protect the tank shut valve, make sure to first close the open/close valve of SST (venting stand).

(2) Close the tank shut valves of the No. 1 hydrogen tank assembly, No. 2 hydrogen tank assembly and No. 3 hydrogen tank assembly.[*2]

(3) Wait until both values "Hydrogen Tank 1 Temperature (Filter Value)", "Hydrogen Tank 2 Temperature (Filter Value)" and "Hydrogen Tank 3 Temperature (Filter Value)" have increased to $-20\text{ }^{\circ}\text{C}$ ($-68\text{ }^{\circ}\text{F}$) or more.[*3]

(4) Open the tank shut valves of the No. 1 hydrogen tank assembly, No. 2 hydrogen tank assembly and No. 3 hydrogen tank assembly.[*4]

Notice:

If the Data List item "Medium-range Hydrogen Pressure (gauge)" decreases to below 0.7 MPa (7.1 kgf/cm^2 , 102 psi) the tank shut valves of the No. 1 hydrogen tank assembly, No. 2 hydrogen tank assembly and No. 3 hydrogen tank assembly will forcibly close.

(5) If the tank shut valves of the No. 1 hydrogen tank assembly, No. 2 hydrogen tank assembly and No. 3 hydrogen tank assembly do not open, open the tank shut valves again.[*5]

- (6) Open the open/close valve of SST (venting stand) and discharge compressed hydrogen gas again.[*6]

Notice:

During the compressed hydrogen gas discharging procedure, if it appears that either "Hydrogen Tank 1 Temperature (Filter Value)", "Hydrogen Tank 2 Temperature (Filter Value)" or "Hydrogen Tank 3 Temperature (Filter Value)" are about to decrease to -30 °C (-86 °F) or less, repeat steps [*1] through [*6].

- q. for 2 Hydrogen Tank:

Read the Data List, and if either of the items "Hydrogen Tank 1 Temperature (Filter Value)" or "Hydrogen Tank 2 Temperature (Filter Value)" have become -30 °C (-86 °F) or less:

- (1) Close the open/close valve of SST (venting stand) [*1]

Notice:

To protect the tank shut valve, make sure to first close the open/close valve of SST (venting stand).

- (2) Close the tank shut valves of the No. 1 hydrogen tank assembly and No. 2 hydrogen tank assembly.[*2]

- (3) Wait until both values "Hydrogen Tank 1 Temperature (Filter Value)" and "Hydrogen Tank 2 Temperature (Filter Value)" have increased to -20 °C (-68 °F) or more.[*3]

- (4) Open the tank shut valves of the No. 1 hydrogen tank assembly and No. 2 hydrogen tank assembly.[*4]

Notice:

If the Data List item "Medium-range Hydrogen Pressure (gauge)" decreases to below 0.7 MPa (7.1 kgf/cm², 102 psi) the tank shut valves of the No. 1 hydrogen tank assembly, No. 2 hydrogen tank assembly will forcibly close.

- (5) If the tank shut valves of the No. 1 hydrogen tank assembly and No. 2 hydrogen tank assembly do not open, open the tank shut valves again.[*5]
- (6) Open the open/close valve of SST (venting stand) and discharge compressed hydrogen gas again.[*6]

Notice:

During the compressed hydrogen gas discharging procedure, if it appears that either "Hydrogen Tank 1 Temperature (Filter Value)" or "Hydrogen Tank 2 Temperature (Filter Value)" are about to decrease to $-30\text{ }^{\circ}\text{C}$ ($-86\text{ }^{\circ}\text{F}$) or less, repeat steps [*1] through [*6].

- r. Check that the Data List item "Medium-range Hydrogen Pressure (gauge)" and the pressure on the pressure indicator of SST (venting stand) are less than 0.8 MPa (8.2 kgf/cm², 116 psi).

Notice:

- The pressure immediately after closing the open/close valve of SST (venting stand) should be less than 0.8 MPa (8.2 kgf/cm², 116 psi) for both the Data List item "Medium-range Hydrogen Pressure (gauge)" and on the pressure indicator of SST (venting stand).
- If either the Data List item "Medium-range Hydrogen Pressure (gauge)" or the pressure on the pressure indicator of SST (venting stand) are 0.8 MPa (8.2 kgf/cm², 116 psi) or greater, open the open/close valve of SST (venting stand) and adjust the pressure.
- After the pressure discharging, when the gas temperature inside the hydrogen tank increases, the pressure will also increase, so make sure to continue discharging until the pressure is less than 0.8 MPa (8.2 kgf/cm², 116 psi).

Hint:

If the pressure immediately after closing the open/close valve of SST (venting stand) is less than 0.8 MPa (8.2 kgf/cm², 116 psi) for both the Data List item "Medium-range Hydrogen Pressure (gauge)" and on the pressure indicator of SST (venting stand), then the pressurized hydrogen gas discharging procedure is complete.

s. for 3 Hydrogen Tank:

Close the tank shut valves of both the No. 1 hydrogen tank assembly, No. 2 hydrogen tank assembly and No. 3 hydrogen tank assembly.

t. for 2 Hydrogen Tank:

Close the tank shut valves of both the No. 1 hydrogen tank assembly and No. 2 hydrogen tank assembly.

10. DISCONNECT SST (HYDROGEN VENTING TOOL)

Caution:

- **While discharging pressurized hydrogen gas, the temperature inside the tank decreases and frost may form on the outside. Do not touch tanks, piping, or SST (hydrogen venting tool) when frost has formed on them.**

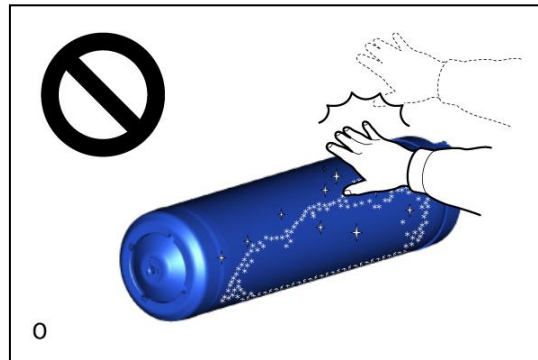

- **Touching tanks, piping, or SST (hydrogen venting tool) on which frost has formed could result in burn-like injuries due to frostbite.**

- a. Using an 8 mm hexagon socket wrench, rotate the adjustment bolt clockwise to close the manual valve of the No. 1 hydrogen tank assembly.

Torque:

25 N*m (255 kgf*cm, 18 ft.*lbf)

Notice:

The manual valve shuts off the pressure from the hydrogen tank assembly, so be careful not to damage the hexagonal portion.

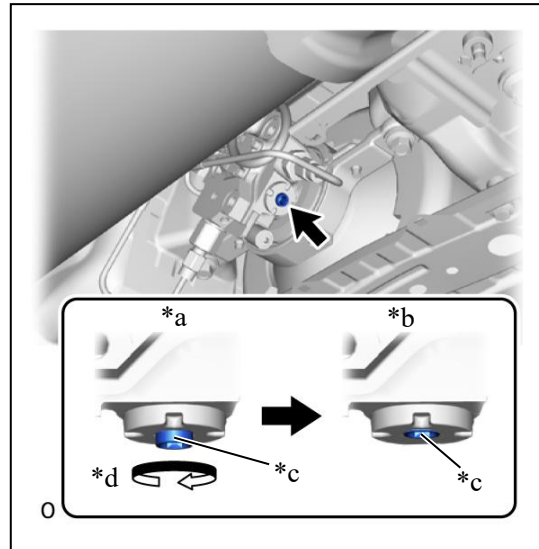

*a	Manual Valve Open
*b	Manual Valve Closed
*c	Adjustment Bolt
*d	Clockwise

- b. Using an 8 mm hexagon socket wrench, rotate the adjustment bolt clockwise to close the manual valve of the No. 2 hydrogen tank assembly.

Torque:

25 N*m (255 kgf*cm, 18 ft.*lbf)

Notice:

The manual valve shuts off the pressure from the hydrogen tank assembly, so be careful not to damage the hexagonal portion.

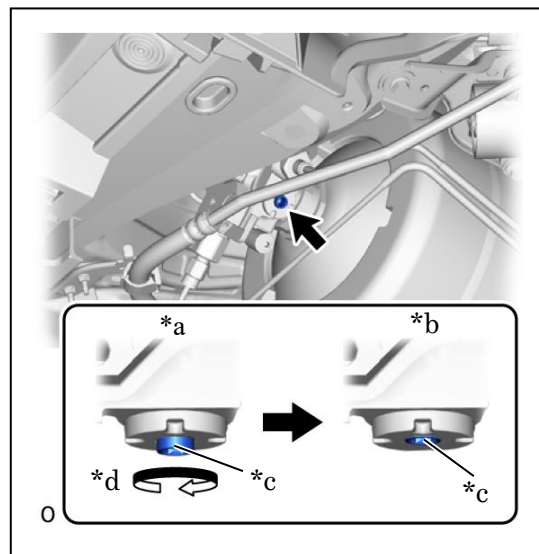

*a	Manual Valve Open
*b	Manual Valve Closed
*c	Adjustment Bolt
*d	Clockwise

- c. for 3 Hydrogen Tank:
Using an 8 mm hexagon socket wrench, rotate the adjustment bolt clockwise to close the manual valve of the No. 3 hydrogen tank assembly.

Torque:

25 N*m (255 kgf*cm, 18 ft.*lbf)

Notice:

The manual valve shuts off the pressure from the hydrogen tank assembly, so be careful not to damage the hexagonal portion.

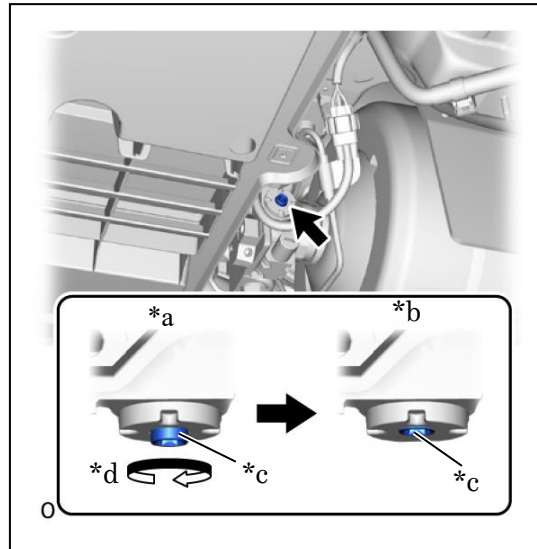

*a	Manual Valve Open
*b	Manual Valve Closed
*c	Adjustment Bolt
*d	Clockwise

- d. Open the open/close valve of SST (venting stand) and discharge the compressed hydrogen gas remaining inside SST (flexible hose).

SST

09404-62010 (09404-06010)

Notice:

- Do not disconnect SST (flexible hose) while there is still pressure remaining inside it.
- Continue discharging until the pressure gauge of SST (Venting Stand) becomes "0".

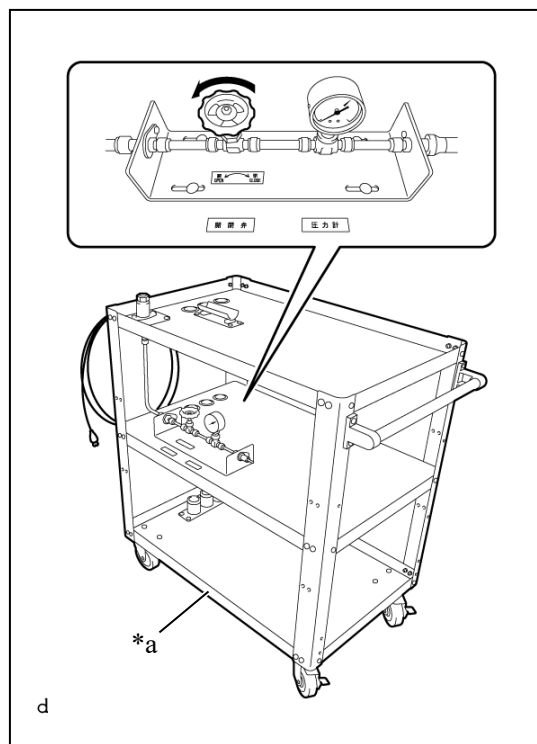

*a	SST (Venting Stand)
----	---------------------

- e. Before performing the disconnection procedure, if there are any contaminants such as water droplets adhering near the medium pressure leak check port of the hydrogen supply regulator, wipe them away before performing the procedure.

- f. Disconnect SST (flexible hose) from SST (Venting Stand).

SST

09404-62010 (09404-06010, 09404-06020)

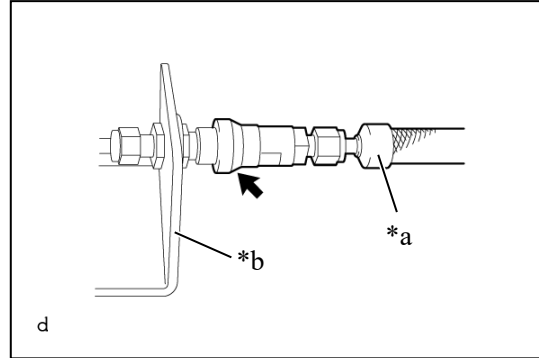

*a	SST (Flexible Hose)
*b	SST (Venting Stand)

- g. for Type A:

- (1) Remove SST (flexible hose) from the hydrogen supply regulator.

SST

09404-62010 (09404-06020)

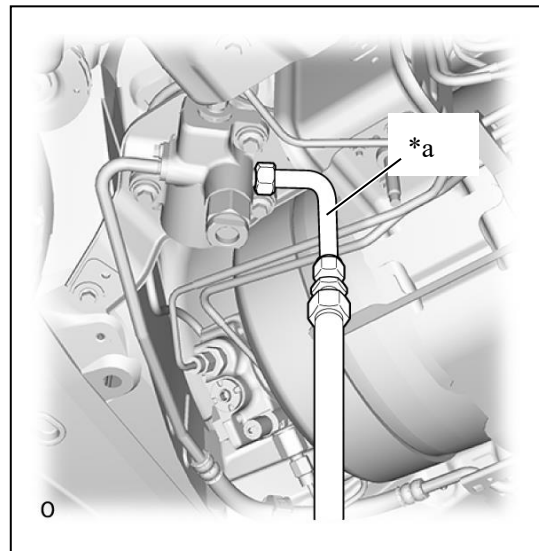

*a	SST (Flexible Hose)
----	---------------------

- h. for Type B:

- (1) Loosen SST (flexible hose).

SST

09404-62010 (09404-06020)

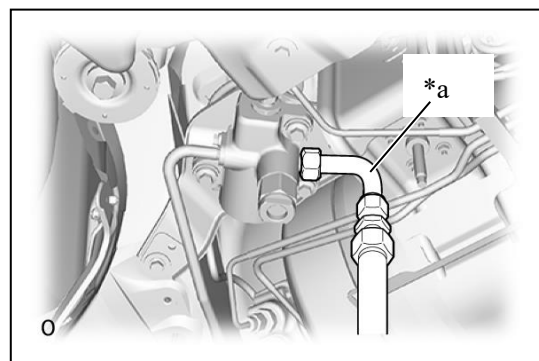

*a	SST (Flexible Hose)
----	---------------------

- (2) Remove the 3 bolts of the hydrogen supply regulator.

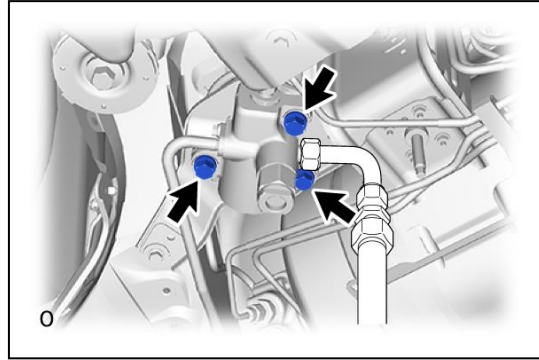

- (3) Remove SST (flexible hose) from the hydrogen supply regulator.

SST

09404-62010 (09404-06020)

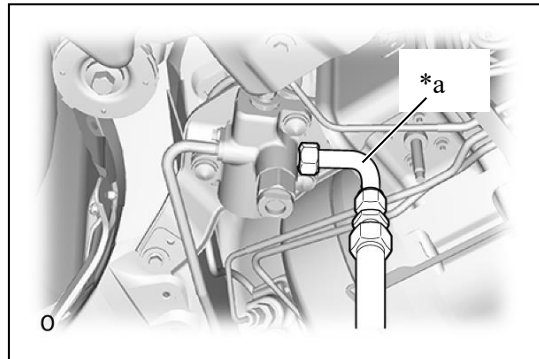

*a	SST (Flexible Hose)
----	---------------------

- (4) Install the hydrogen supply regulator with the 3 bolts.

Torque:

16.5 N*m (168 kgf*cm, 12 ft.*lbf)

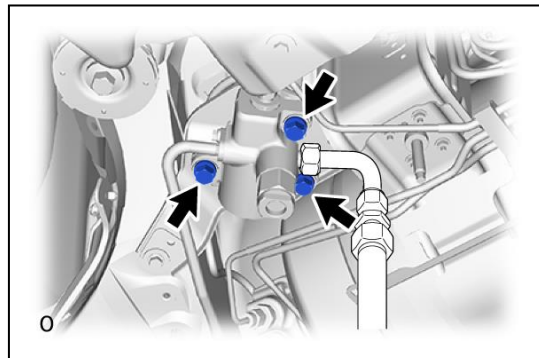

Determine Discharging Method

	<p>CAUTION: Since high voltage accumulates within the FC stack assembly with FC converter, never perform the work of separating this part into the FC converter assembly and FC stack assembly without first performing electrical charge discharge (forced electrical charge discharge or electrical charge self-discharge), because doing so is dangerous.</p> <p>HINT:</p> <ul style="list-style-type: none">• Forced electrical charge discharge involves injecting nitrogen to forcibly discharge the electrical charge within the FC stack assembly with FC converter, thereby reducing the voltage within the FC stack assembly with FC converter to a level where work can be performed safely.• Electrical charge self-discharge involves removing parts such as the air pressure regulator assembly to discharge the electrical charge through self-discharge, thereby reducing the voltage within the FC stack assembly with FC converter to a level where work can be performed safely.• When the auxiliary components operate normally, forced electrical charge discharge can be performed.• If any of the auxiliary components do not operate, forced electrical charge discharge cannot be performed. Perform electrical charge self-discharge.
---	--

11. PRESENCE OF VEHICLE EXTERNAL DAMAGE (ACCIDENT)

- a. Check the FC stack assembly and area near the FC stack assembly for any damage that requires body repair or replacement.
- b. Check the areas shown in the illustration for damage such as cracks, dents, chips and other deformation.

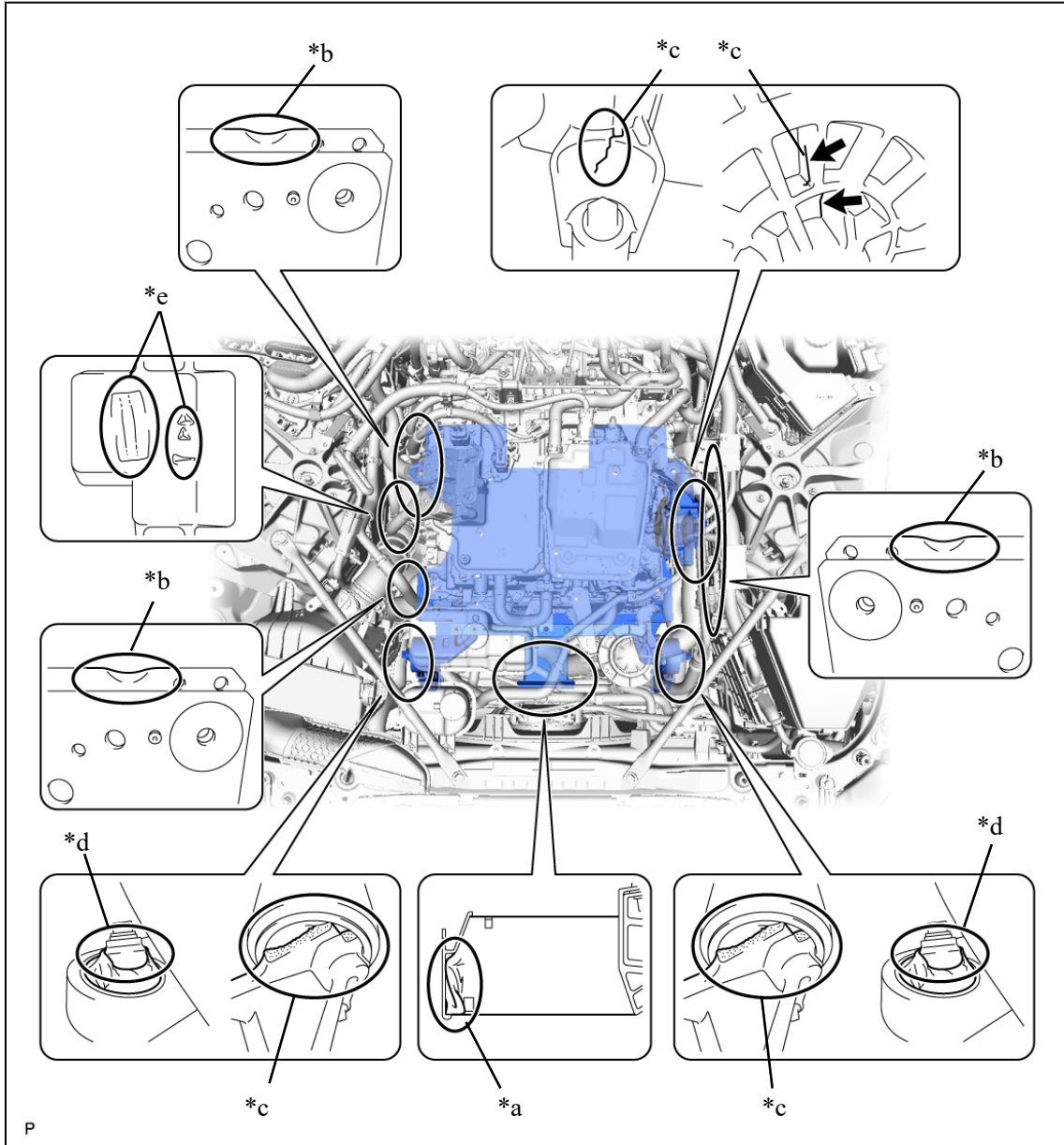

*a	Crushing and Wrinkles	*b	Dents
*c	Cracks	*d	Cut Rubber
*e	Scratches	-	-

Hint:

If any is found, the FC stack assembly may be malfunctioning.

- (a) The FC stack assembly interferes with other parts and has damage such as scratches.
- (b) ii. Parts and areas integrated with the FC stack assembly shown in the table below interfere with other parts and have damage such as scratches.

Check Locations:

Parts	Parts Position	Interfering Parts
FC stack frame assembly	FC stack frame assembly (Crash box)	Fan with motor assembly
	FC stack frame assembly (side)	<ul style="list-style-type: none">• Front side member RH• Front side member LH
FC converter spacer	FC converter assembly (RH side)	<ul style="list-style-type: none">• Front side member RH• Front fender apron (RH side)
<ul style="list-style-type: none">• Front FC mounting bracket RH• Front FC mounting bracket LH• Front FC mounting insulator RH• Front FC mounting insulator LH	Front	<ul style="list-style-type: none">• Fan with motor assembly• Areas fastened to FC stack assembly
FC cooling water temperature control valve	Areas fastened to FC stack assembly	<ul style="list-style-type: none">• Front side member LH• Front fender apron (LH side)

Result:

Result	Proceed to
NG	Perform electrical charge self-discharge. (Perform after lowering the FC stack assembly with FC converter with front frame assembly from the vehicle. Perform the procedure up to "Perform Electrical Charge Self-discharge (When Forced Electrical Charge Discharge Not Possible)".)
OK	Go to next step 2.

12. CHECK NO. 1 HYDROGEN SUPPLY TUBE SUB-ASSEMBLY AND NO. 2 HYDROGEN SUPPLY TUBE SUB-ASSEMBLY PIPES

- a. Check that the required pipes are not cracked, bent or damaged.

Result:

Result	Proceed to
NG	Perform electrical charge self-discharge. (Perform after lowering the FC stack assembly with FC converter with front frame assembly from the vehicle. Perform the procedure up to "Perform Electrical Charge Self-discharge (When Forced Electrical Charge Discharge Not Possible)".)
OK	Go to next step 3.

13. CHECK HV/EV BATTERY SOC

- a. Connect the GTS to the DLC3.
 b. Turn the ignition switch to ON.
 c. Enter the following menus: Powertrain / EV / Data List / HV/EV battery SOC.

Powertrain > EV > Data List

Tester Display
Hybrid/EV Battery SOC

- d. Check the HV/EV battery SOC.

Standard Percentage:

30 % or higher

Result:

Result	Proceed to
NG	Perform electrical charge self-discharge. (Perform after lowering the FC stack assembly with FC converter with front frame assembly from the vehicle. Perform the procedure up to "Perform Electrical Charge Self-discharge (When Forced Electrical Charge Discharge Not Possible)".)
OK	Go to Perform Forced Electrical Charge Discharge Work

Forced Electrical Charge Discharge Work

1. CONNECT NITROGEN GAS INJECTOR (SST)

- a. Remove the bolt and disconnect the No. 2 hydrogen supply tube sub-assembly.

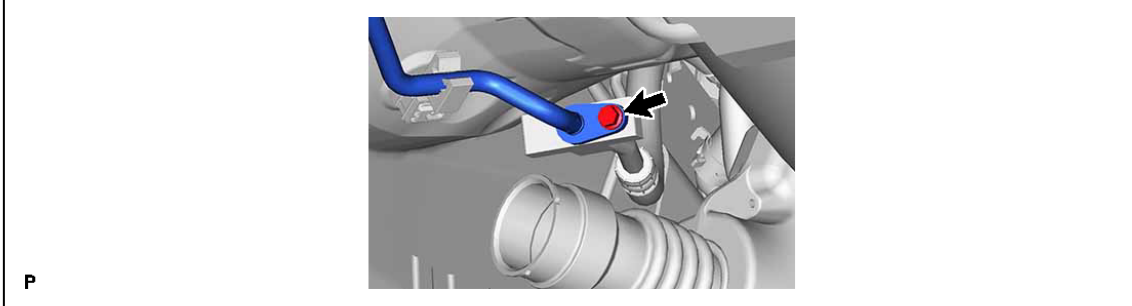

- b. To prevent entry of foreign matter, etc., protect the connector of the No. 2 hydrogen supply tube sub-assembly with a plastic bag, etc.
- c. Check that the container valve of the nitrogen cylinder is closed.
- d. Check that the regulating valve of the regulator (SST) is closed.
- e. Connect the regulator (SST) to the nitrogen cylinder.

SST

09761-50010 (09761-05010)

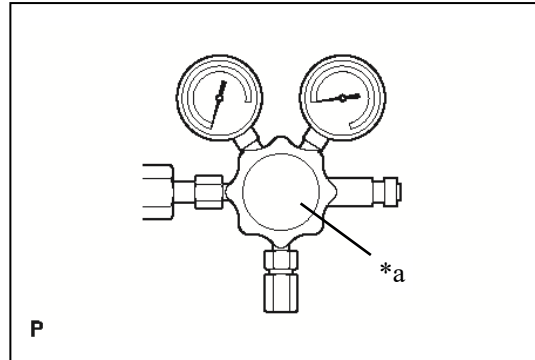

*a	Regulating Valve
----	------------------

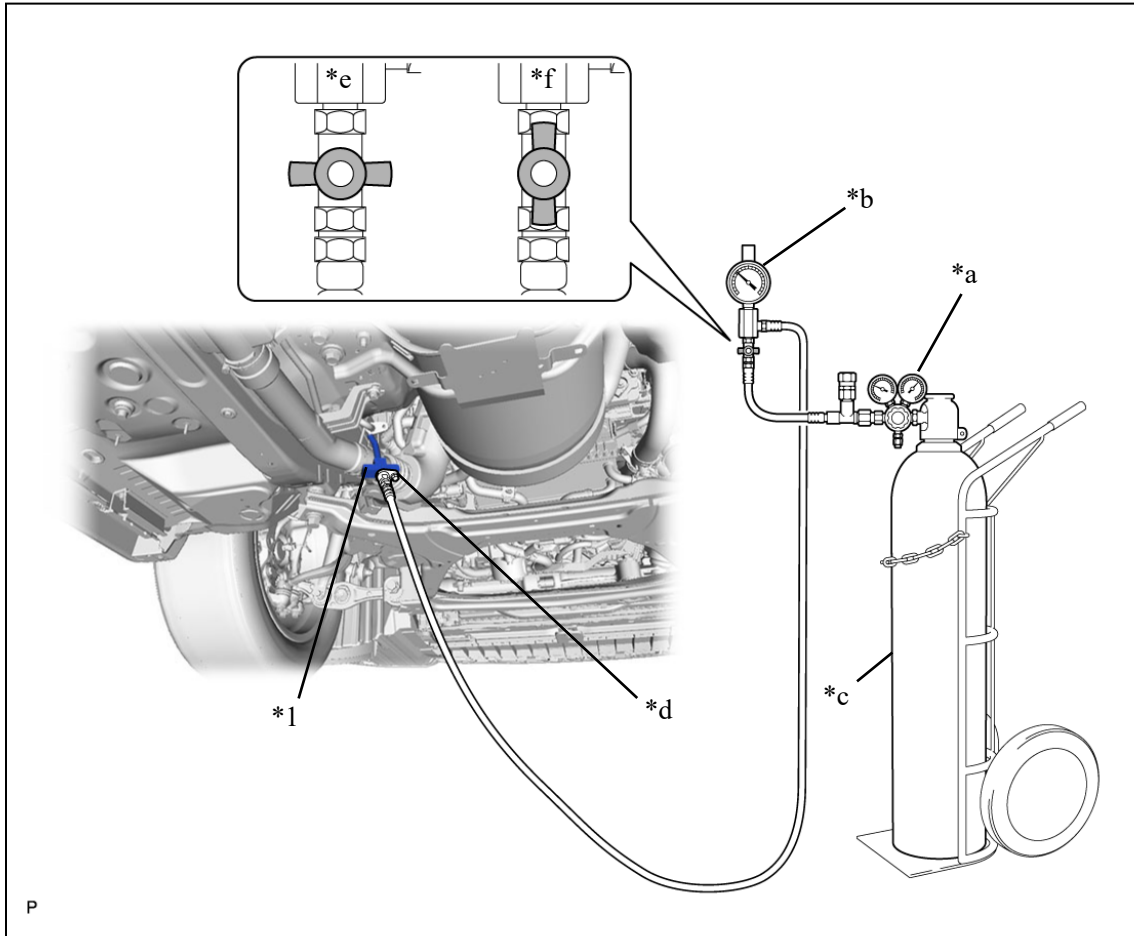

*1	No. 1 Hydrogen Supply Tube Sub-assembly	-	-
*a	Regulator (SST)	*b	Nitrogen Gas Injector (SST)
*c	Nitrogen Cylinder	*d	Tightening Bolt of No. 2 Hydrogen Supply Tube Sub-assembly
*e	Close	*f	Open

- f. Check that the valve of the nitrogen gas injector (SST) is closed.
- g. Connect the nitrogen gas injector (SST) to the regulator (SST).

SST

09406-62010

- h. Connect the nitrogen gas injector (SST) to the No. 1 hydrogen supply tube sub-assembly with the tightening bolt of the No. 2 hydrogen supply tube sub-assembly.

Torque:

10 N*m (102 kgf*cm, 7 ft.*lbf)

- i. Lower the lift.

2. CHECK FOR NITROGEN GAS INJECTOR (SST) CONNECTION LEAKS

- a. Open the container valve of the nitrogen cylinder.

Hint:

The pressure of the gauge on the right side of the regulator (SST) increases.

- b. While operating the regulating valve of the regulator (SST), close the container valve of the nitrogen cylinder so that the pressure is 1 MPa.

Hint:

Check from the pressure of the gauge on the left side of the regulator (SST).

- c. After 10 minutes have passed, check that the pressure has not decreased.

Hint:

If the pressure has decreased, check the connection of the regulator (SST) and nitrogen gas injector (SST).

- d. Connect the battery charger to the auxiliary battery.

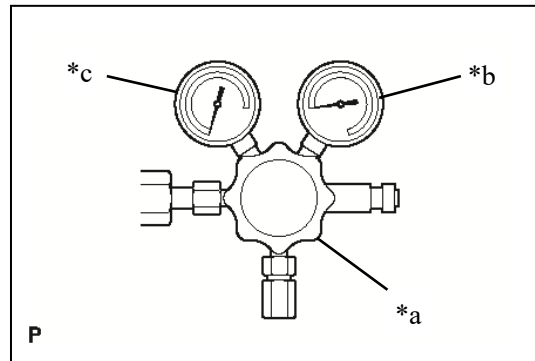

*a	Regulating Valve
*b	Gauge on Right Side of Regulator (SST)
*c	Gauge on Left Side of Regulator (SST)

3. PERFORM FORCED ELECTRICAL CHARGE DISCHARGE

- a. Connect the GTS to the DLC3.
- b. Turn the ignition switch to ON.
- c. Turn the GTS on.
- d. Enter the following menus: Powertrain / EV / Utility / FC Stack Electric Charge Release

Powertrain > EV > Utility

Tester Display
FC Stack Electric Charge Release

Notice:

- In Utility, do not open or close the container valve of the nitrogen cylinder until instructed on the GTS monitor screen.
- When an abnormal end is displayed on the monitor screen in Utility, stop forced electrical charge discharge immediately.

Hint:

When the instruction for opening the container valve of the nitrogen cylinder is displayed in Utility, operate the regulating valve of the regulator (SST) and adjust the value of the nitrogen gas injector (SST) gauge to 1 MPa.

- e. After Utility ends, check again that the container valve of the nitrogen cylinder is closed.
- f. Close the regulating valve of the regulator (SST).
- g. Close the valve of the nitrogen gas injector (SST).
- h. Gradually loosen the connection of the regulator (SST) and nitrogen gas injector (SST) to remove the nitrogen pressure inside the connected devices.

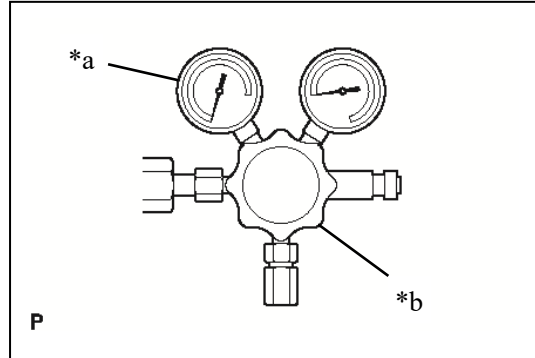

Hint:

Be sure to perform this work because it removes the nitrogen pressure inside the connected devices.

*a	Gauge on Left Side of Regulator (SST)
*b	Regulating Valve

- i. Remove the nitrogen gas injector (SST) from the regulator (SST).
- j. Gradually open the valve of the nitrogen gas injector (SST) to remove the pressure from the vehicle side.
- k. Remove the tightening bolt of the No. 2 hydrogen supply tube sub-assembly, and then disconnect the nitrogen gas injector (SST) from the No. 1 hydrogen supply tube sub-assembly.
- l. Protect the openings of the No. 1 hydrogen supply tube sub-assembly with protective tape (non-residue type) to prevent the entry of foreign matter or water.

Result:

Result	Proceed to
Normal end	End forced electrical charge discharge.
Abnormal end	Perform electrical charge self-discharge. (Perform after lowering the FC stack assembly with FC converter with front frame assembly from the vehicle. Perform the procedure up to "Perform Electrical Charge Self-discharge (When Forced Electrical Charge Discharge Not Possible)".)

Removal of EV Battery

Before Proceeding to the EV Battery Removal Instructions

The following 5 pages contain general instructions for use when working on a MIRAI.

Read these instructions before proceeding to the EV battery removal instructions on page 83.



WARNING:

- ***The high voltage system may remain powered for up to 10 minutes after the vehicle is shut off or disabled. To prevent serious injury or death from severe burns or electric shock, avoid touching, cutting, or breaching any orange high voltage power cable or any high voltage component.***

1. Shut off the ignition (READY indicator is off).
2. Remove luggage trim service hole cover.
 - a.

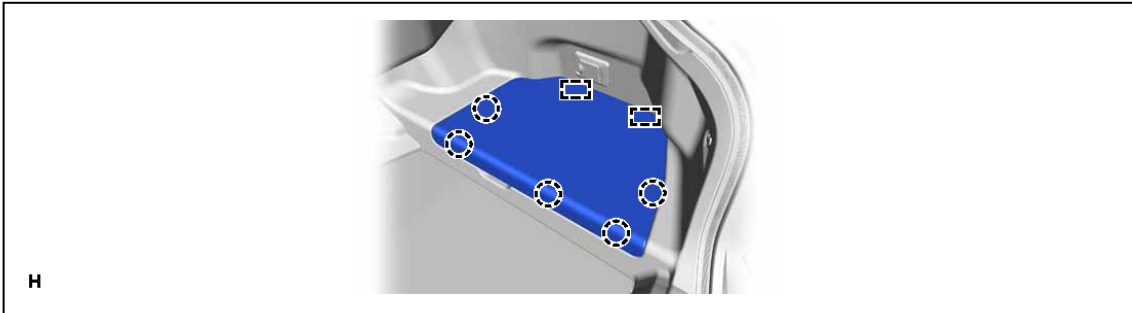

3. Disconnect cable from negative auxiliary battery terminal.
 - a.

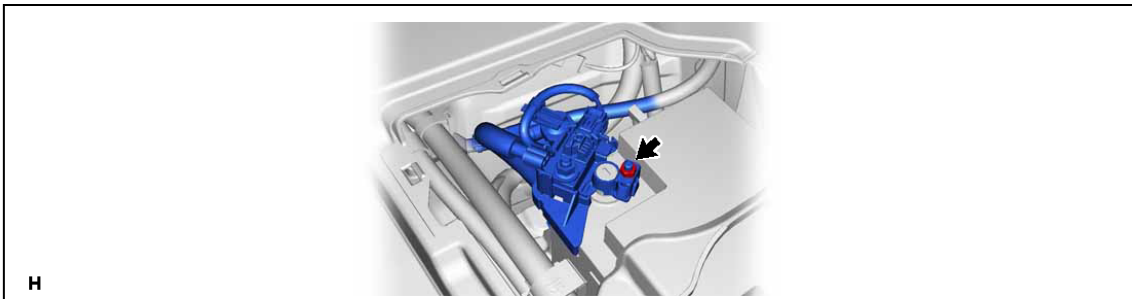

4. Remove No. 8 EV battery shield panel.

a.

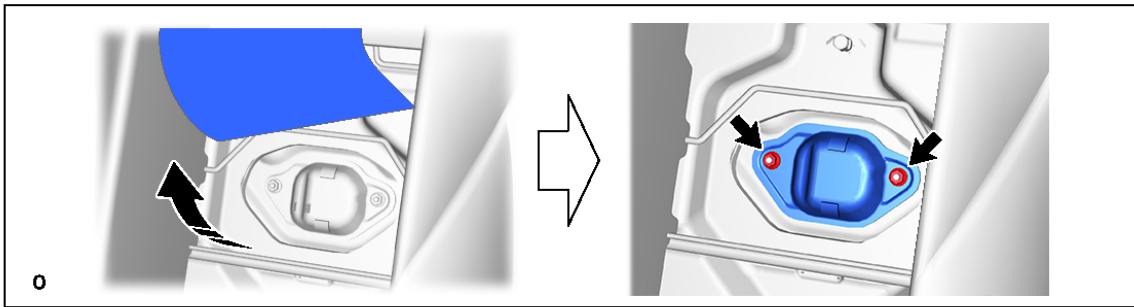

5. Remove service plug grip.

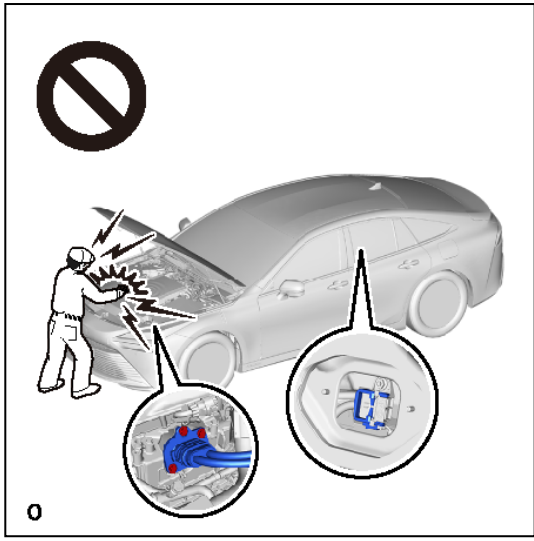
	<p>CAUTION:</p> <ul style="list-style-type: none">• Be sure to wear insulated gloves.• Do not inspect or service the high voltage system with the service plug grip and FC converter power outlet cable (inverter with converter assembly) installed.• To reduce the risk of electric shock, make sure to remove the service plug grip and FC converter power outlet cable (inverter with converter assembly) to cut off the high voltage circuit before servicing the vehicle.• Make sure to remove the service plug grip first, and then remove the FC converter power outlet cable (inverter with converter assembly). <div data-bbox="813 817 1348 1355" style="border: 1px solid black; padding: 5px;"></div>
---	---

- To reduce the risk of electric shock, make sure to wait at least 10 minutes after removing the service plug grip and FC converter power outlet cable (inverter with converter assembly) to fully discharge the high voltage capacitor inside the inverter with converter assembly.
- Keep the removed service plug grip in your pocket to prevent other technicians from accidentally installing it while you are servicing the vehicle.

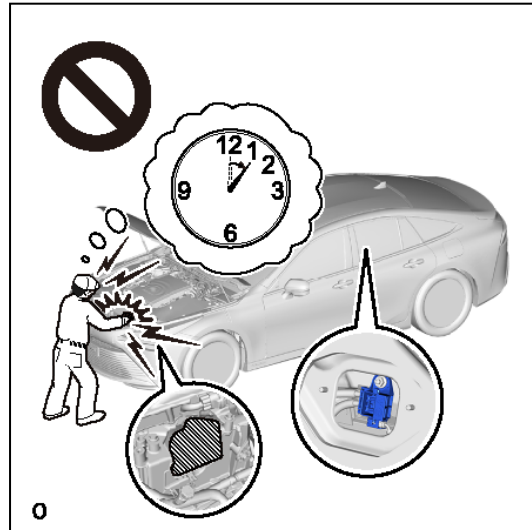

NOTICE:

- After removing the service plug grip and FC converter power outlet cable (inverter with converter assembly), turning the ignition switch to ON (READY) may cause a malfunction. Do not turn the ignition switch to ON (READY) unless instructed by the repair manual.
- Do not touch the terminals of the service plug grip and FC converter power outlet cable (inverter with converter assembly).
- If the service plug grip has been struck or dropped, replace it.

HINT:

Waiting for at least 10 minutes is required to discharge the high voltage capacitor inside the inverter with converter assembly.

a.

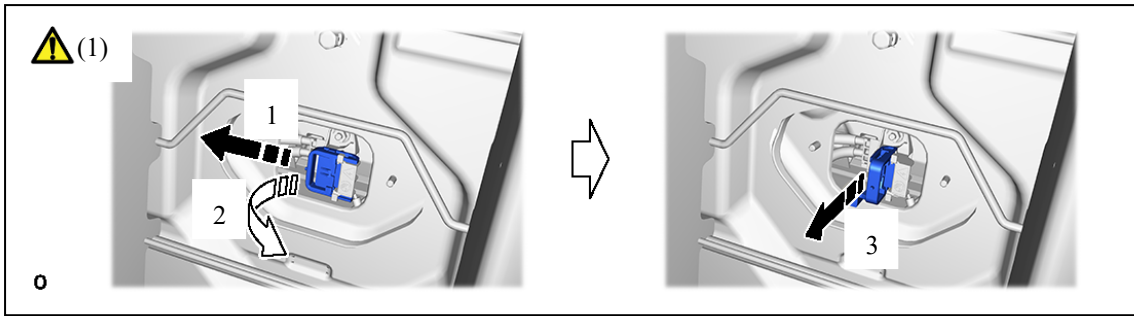

(1) While wearing insulated gloves, rotate the handle of the service plug grip and remove the service plug grip as indicated by the arrows in the order shown in the illustration.

6. Carry the removed service plug grip in your pocket to prevent other staff from accidentally reinstalling it while you are dismantling the vehicle.
7. Make other staff aware that a high-voltage system is being dismantled by using the following sign: CAUTION: HIGH-VOLTAGE. DO NOT TOUCH (see page 83).
8. If the service plug grip cannot be removed due to damage to the vehicle, remove the **IG2 P NO.1** fuse (10 A).

Caution:

This operation shuts off the HV system. Be sure to wear insulated gloves because high voltage is not shut off inside the EV battery. When it is possible to remove the service plug grip, remove it and continue the procedure.

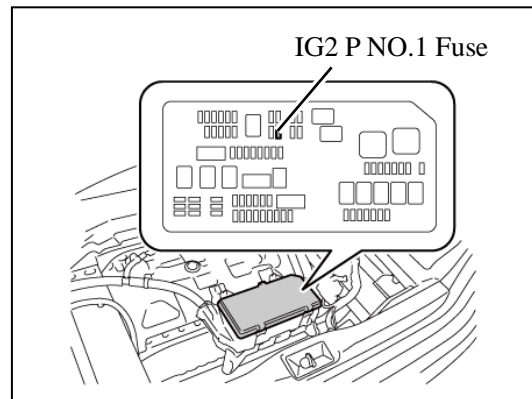

9. After disconnecting or exposing a high-voltage connector or terminal, insulate it immediately using insulating tape. Before touching a bare high-voltage terminal, wear insulated gloves. Check the EV battery and nearby area for leakage. If you find any liquid, it may be strong alkaline electrolyte. Wear rubber gloves and goggles and neutralize the liquid using a saturated boric acid solution or vinegar. Then wipe up the liquid using waste rags etc.

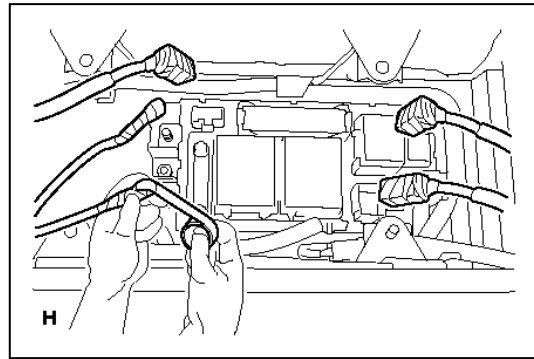

10. If the electrolyte comes into contact with your skin, wash the skin immediately using a saturated boric acid solution or a large amount of water. If the electrolyte adheres to any article of clothing, take the clothing off immediately.
11. If the electrolyte comes into contact with your eye(s), call out loudly for help. Do not rub your eye(s). Instead, wash the eye(s) with a dilute boric acid solution or a large amount of water and seek medical care.
12. With the exception of the EV battery, remove parts by following procedures which are similar to conventional Toyota vehicles. For the removal of the EV battery, refer to the following pages.

Person in charge: _____

CAUTION:
HIGH-VOLTAGE.
DO NOT TOUCH.

CAUTION:
HIGH-VOLTAGE.
DO NOT TOUCH.

Person in charge: _____

When performing work on the EV system, fold this sign and
put it on the roof of the vehicle.

Removal of EV Battery



WARNING:

- ***Be sure to wear insulated gloves when handling high-voltage parts.***
- ***Even if the vehicle is shut off and the relays are off, be sure to remove the service plug grip before performing any further work.***
- ***Power remains in the high voltage electrical system for 10 minutes even after the HV battery pack is shut off because the circuit has a condenser that stores power.***
- ***Make sure that the tester reading is 0 V before touching any high-voltage terminals which are not insulated.***
- ***The SRS may remain powered for up to 90 seconds after the vehicle is shut off or disabled. To prevent serious injury or death from unintentional SRS deployment, avoid cutting the SRS components.***

1. PRECAUTION



NOTICE:

- **Make sure to insulate the high-voltage connectors and terminals of the EV battery with insulating tape after removing it.**
If the EV battery stored without insulating the connectors and terminals, electric shock or fire may result.
- **Do not touch any high voltage wire harnesses, connectors or parts with bare hands.**



- Hold the areas shown in the illustration and lift the EV battery.
- Do not break the No. 1 EV battery carrier sheet.
- Do not allow foreign matter, such as grease or oil, to adhere to the bolts or nuts of the EV battery.
- Do not put your hands into the openings of the EV battery.
- When removing/installing/moving the EV battery assembly, make sure not to tilt it more than 80°.
- Do not climb on top of or stand on the EV battery.
- Do not allow any foreign matter or water to enter the EV battery.
- If any bolts, nuts or clips are dropped into the EV battery, make sure to remove them.

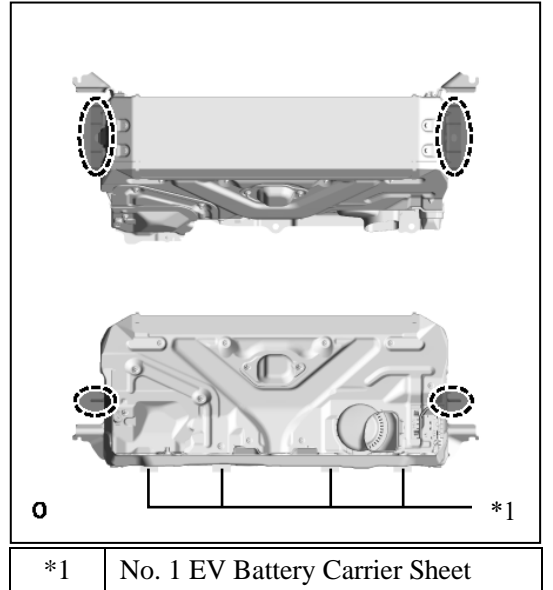

2. READ VALUE USING GTS

a.

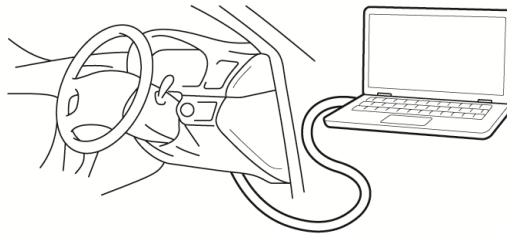

(1) Read the Data List.

Powertrain > EV > Data List

Tester Display
Hybrid/EV Battery Temperature 1
Hybrid/EV Battery Temperature 2
Hybrid/EV Battery Temperature 3
Hybrid/EV Battery Temperature 4
Hybrid/EV Battery Temperature 5
Hybrid/EV Battery Temperature 6

Notice:

If any of the temperatures listed in "Hybrid/EV Battery Temperature 1 to 6" are 50°C or more, leave the vehicle until the temperature drops to less than 50°C.

3. REMOVE NO. 8 EV BATTERY SHIELD PANEL

a.

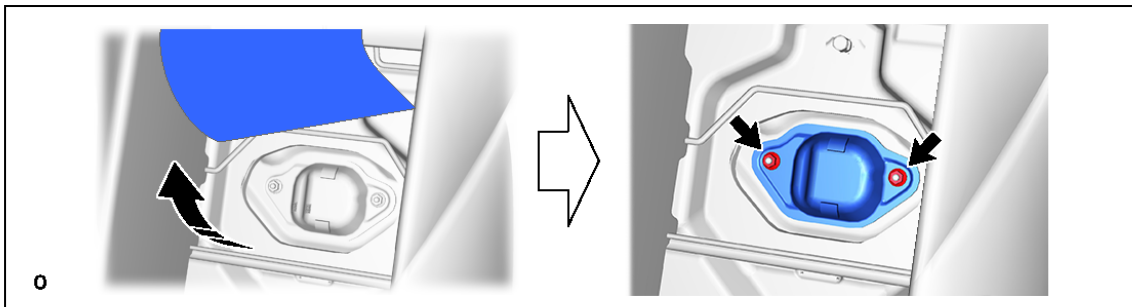

4. REMOVE SERVICE PLUG GRIP

CAUTION:

- Be sure to wear insulated gloves.
- Do not inspect or service the high voltage system with the service plug grip and FC converter power outlet cable (inverter with converter assembly) installed.
- To reduce the risk of electric shock, make sure to remove the service plug grip and FC converter power outlet cable (inverter with converter assembly) to cut off the high voltage circuit before servicing the vehicle.

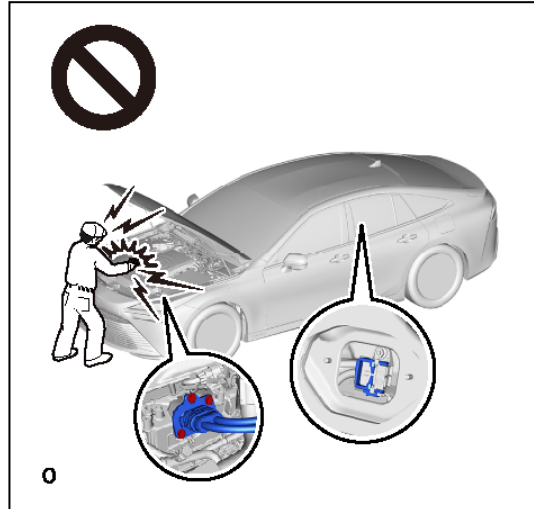

- Make sure to remove the service plug grip first, and then remove the FC converter power outlet cable (inverter with converter assembly).
- To reduce the risk of electric shock, make sure to wait at least 10 minutes after removing the service plug grip and FC converter power outlet cable (inverter with converter assembly) to fully discharge the high voltage capacitor inside the inverter with converter assembly.
- Keep the removed service plug grip in your pocket to prevent other technicians from accidentally installing it while you are servicing the vehicle.

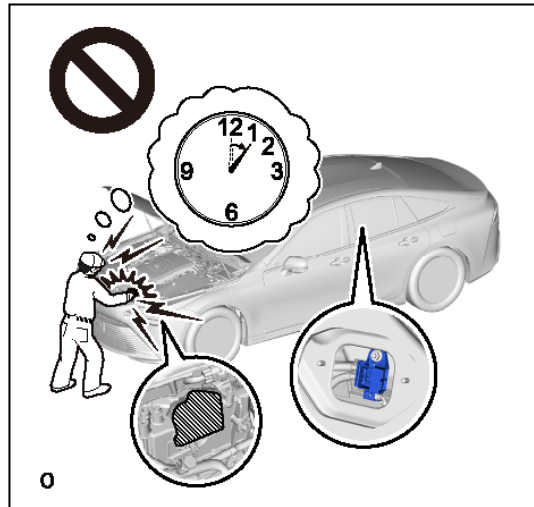

NOTICE:

- After removing the service plug grip and FC converter power outlet cable (inverter with converter assembly), turning the ignition switch to ON (READY) may cause a malfunction. Do not turn the ignition switch to ON (READY) unless instructed by the repair manual.
- Do not touch the terminals of the service plug grip and FC converter power outlet cable (inverter with converter assembly).

HINT:
Waiting for at least 10 minutes is required to discharge the high voltage capacitor inside the inverter with converter assembly.

a.

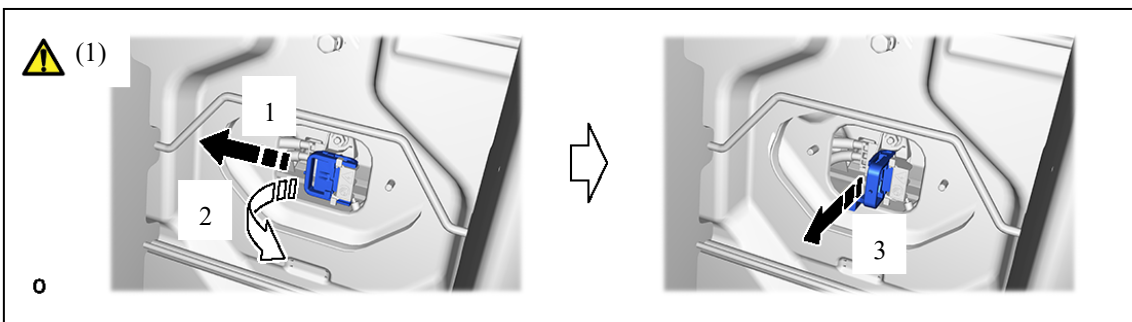

(1) While wearing insulated gloves, rotate the handle of the service plug grip and remove the service plug grip as indicated by the arrows in the order shown in the illustration.

5. REMOVE UPPER RADIATOR SUPPORT SEAL

a.

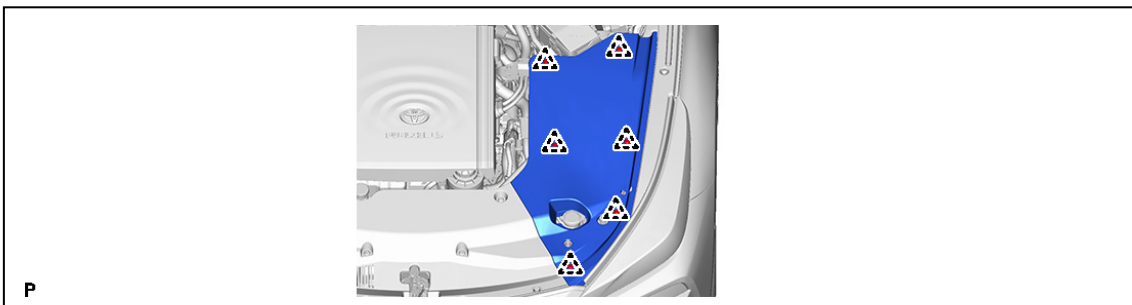

6. REMOVE RADIATOR COVER PLATE

a.

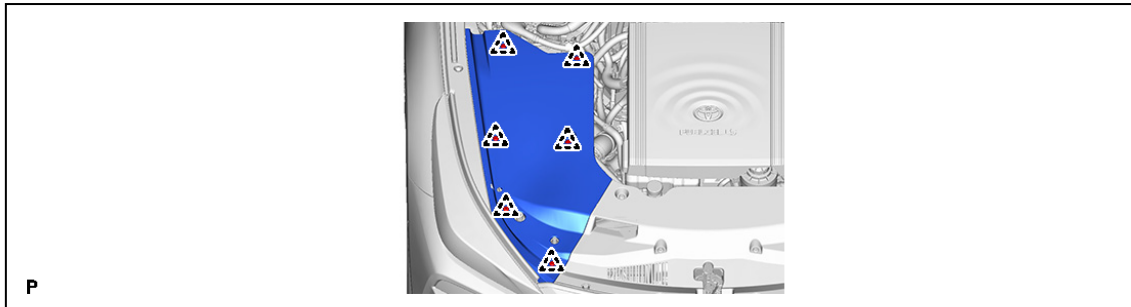

7. REMOVE LOWER RADIATOR AIR DEFLECTOR

a.

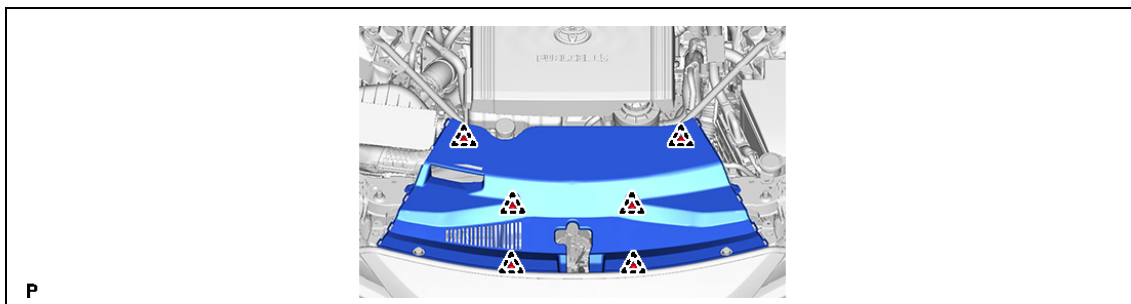

8. REMOVE FC STACK COVER SUB-ASSEMBLY

a.

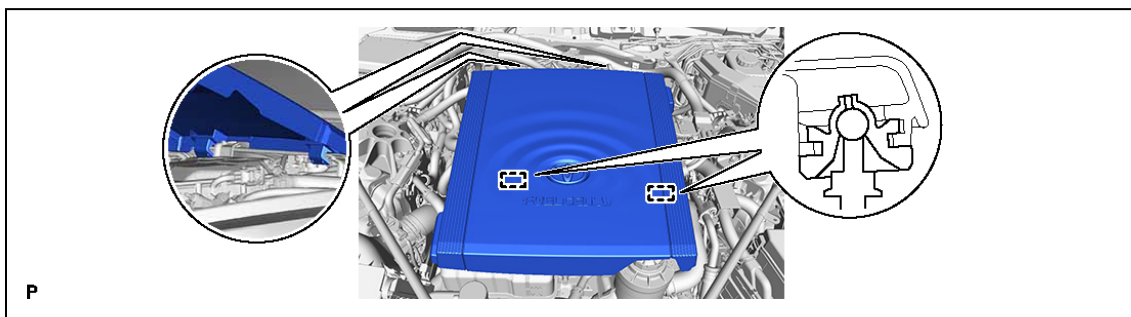

9. CAUTIONS FOR COOLANT (TOYOTA GENUINE FC STACK COOLANT (Premixed))

	<p>NOTICE:</p> <ul style="list-style-type: none">• This vehicle performs FC system shutdown process after turning the ignition switch off from ON (READY). Therefore, after the ignition switch is turned off from ON (READY), do not perform any work on the electrical system for at least 10 minutes including removing connectors or disconnecting the negative (-) auxiliary battery terminal.• When the vehicle is parked with the ignition switch off, if the FC control ECU judges that the FC stack temperature will go below 0°C (32°F), it activates the FC air compressor, hydrogen pump and FC cooling water pump for a maximum of 180 seconds and drains water from the FC stack assembly. When performing inspection or repairs with the ignition switch off (not on (IG) or on (READY)), disconnect the cable from the negative (-) auxiliary battery terminal before performing work.
---	--

10. DRAIN COOLANT (TOYOTA GENUINE FC STACK COOLANT (Pre-mixed))

CAUTION:

- When the coolant (Toyota genuine FC stack coolant (Pre-mixed)) is hot, do not remove the reserve tank cap, FC radiator assembly drain cock plug or the intercooler assembly side drain cock plug.
- Fluid and steam may spray out due to high pressure, possibly resulting in burns.

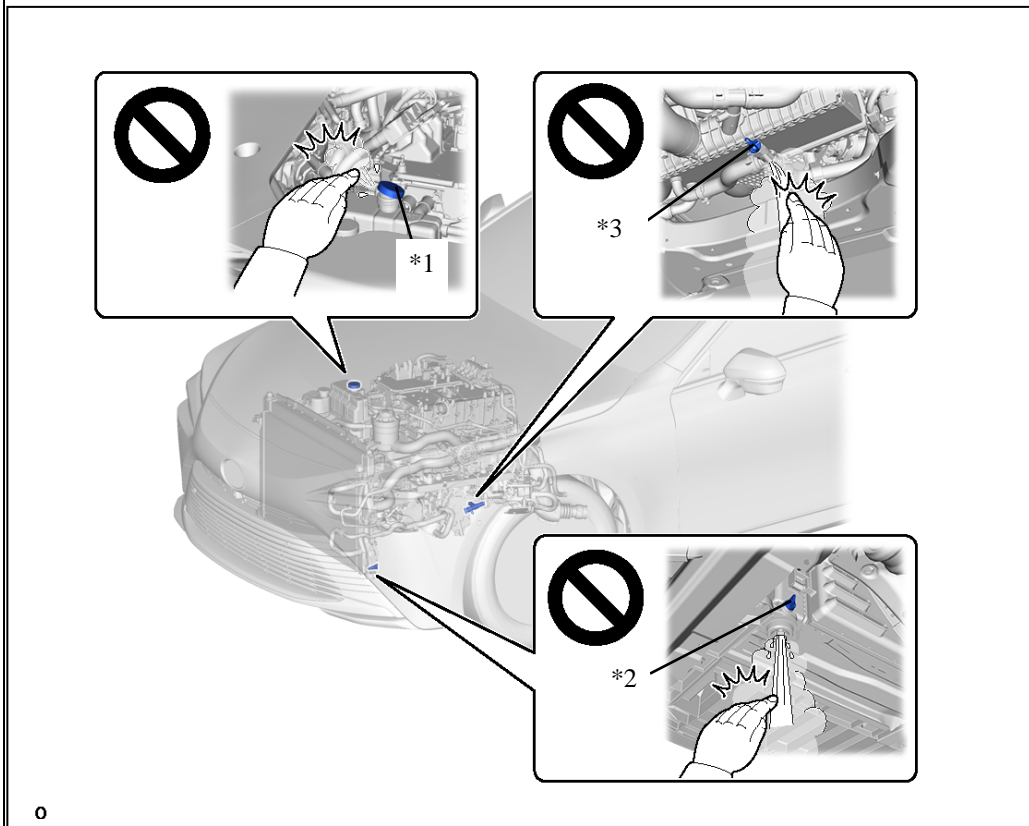

*1	Reserve Tank Cap	*2	FC Radiator Assembly Drain Cock Plug
*3	Intercooler Assembly Side Drain Cock Plug	-	-

- a. Connect a hose with an inside diameter of 9 mm (0.354 in.) to the FC radiator assembly drain cock as shown in the illustration.

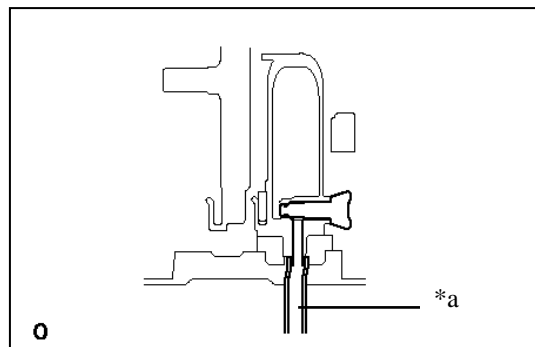

*a	Hose
----	------

- b. Connect a hose with an inside diameter of 8 mm (0.315 in.) to the intercooler assembly side drain cock plug as shown in the illustration.

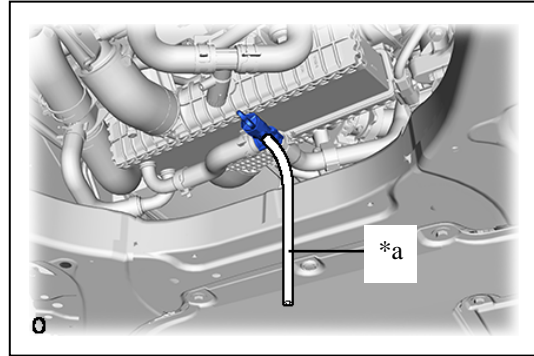

*a	Hose
----	------

- c. Loosen the FC radiator assembly drain cock plug and intercooler assembly side drain cock plug.

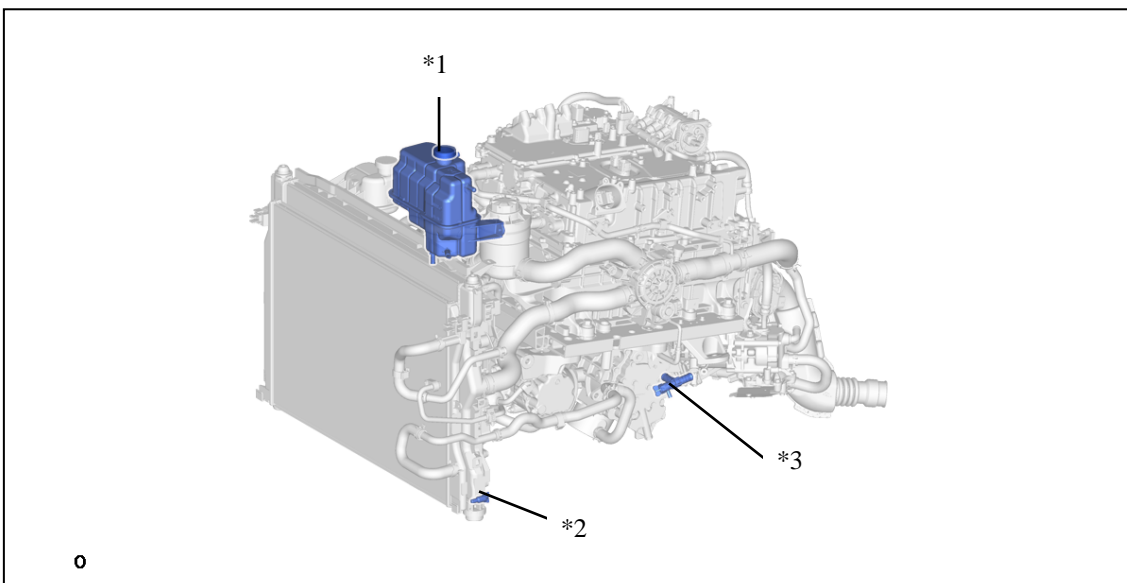

*1	Reserve Tank Cap	*2	FC Radiator Assembly Drain Cock Plug
*3	Intercooler Assembly Side Drain Cock Plug	-	-

- d. Remove the reserve tank cap. Then drain the engine coolant (Toyota genuine FC stack coolant (Premixed)).
- e. Tighten the FC radiator assembly drain cock plug and intercooler assembly side drain cock plug by hand.
- f. Disconnect the hose from the FC radiator assembly drain cock plug and intercooler assembly side drain cock plug.

11. DISCONNECT FC CONVERTER POWER OUTLET CABLE (INVERTER WITH CONVERTER ASSEMBLY)

CAUTION:

- Be sure to wear insulated gloves.
- Do not inspect or service the high voltage system with the service plug grip and FC converter power outlet cable (inverter with converter assembly) installed.
- To reduce the risk of electric shock, make sure to remove the service plug grip and FC converter power outlet cable (inverter with converter assembly) to cut off the high voltage circuit before servicing the vehicle.

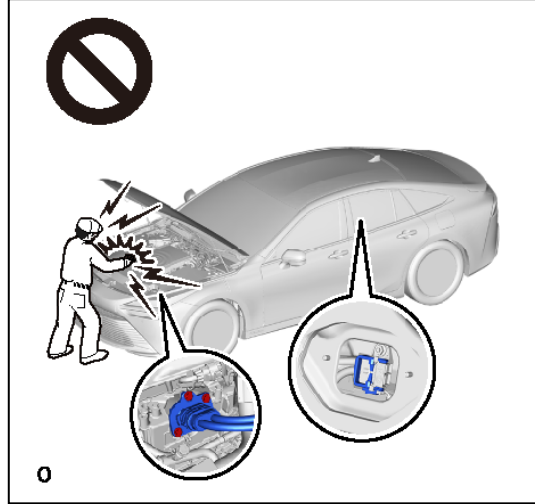

- Make sure to remove the service plug grip first, and then remove the FC converter power outlet cable (inverter with converter assembly).
- To reduce the risk of electric shock, make sure to wait at least 10 minutes after removing the service plug grip and FC converter power outlet cable (inverter with converter assembly) to fully discharge the high voltage capacitor inside the inverter with converter assembly.
- Keep the removed service plug grip in your pocket to prevent other technicians from accidentally installing it while you are servicing the vehicle.

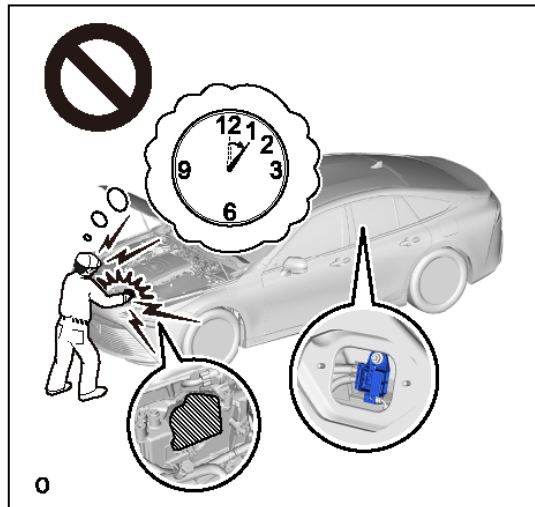

	<p>NOTICE:</p> <ul style="list-style-type: none"> • After removing the service plug grip and FC converter power outlet cable (inverter with converter assembly), turning the ignition switch to ON (READY) may cause a malfunction. Do not turn the ignition switch to ON (READY) unless instructed by the repair manual. • Do not touch the terminals of the service plug grip and FC converter power outlet cable (inverter with converter assembly). <p>HINT:</p> <p>Waiting for at least 10 minutes is required to discharge the high voltage capacitor inside the inverter with converter assembly.</p>
---	--

a.

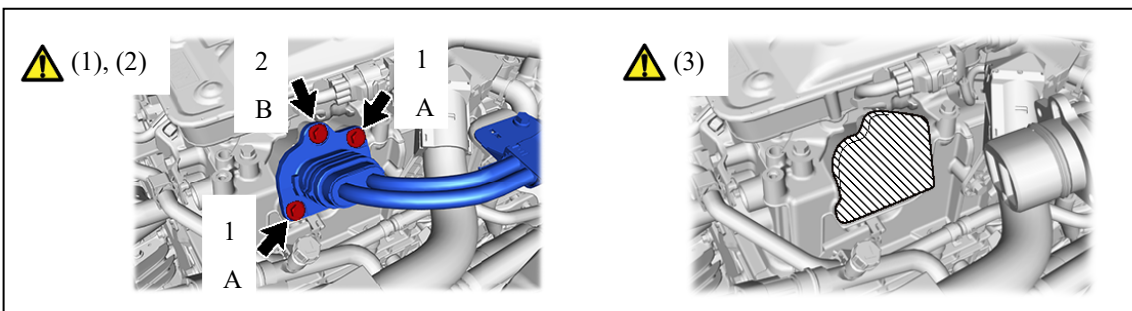

(1) Remove the 2 bolts A and bolt B in the order shown in the illustration.

Notice:

Removing the bolts in an incorrect order may damage the FC converter and FC converter power outlet cable (inverter with converter assembly).

- (2) Disconnect the FC converter power outlet cable (inverter with converter assembly).
- (3) Protect the openings of the FC converter assembly with protective tape (non-residue type) to prevent the entry of foreign matter or water.

b.

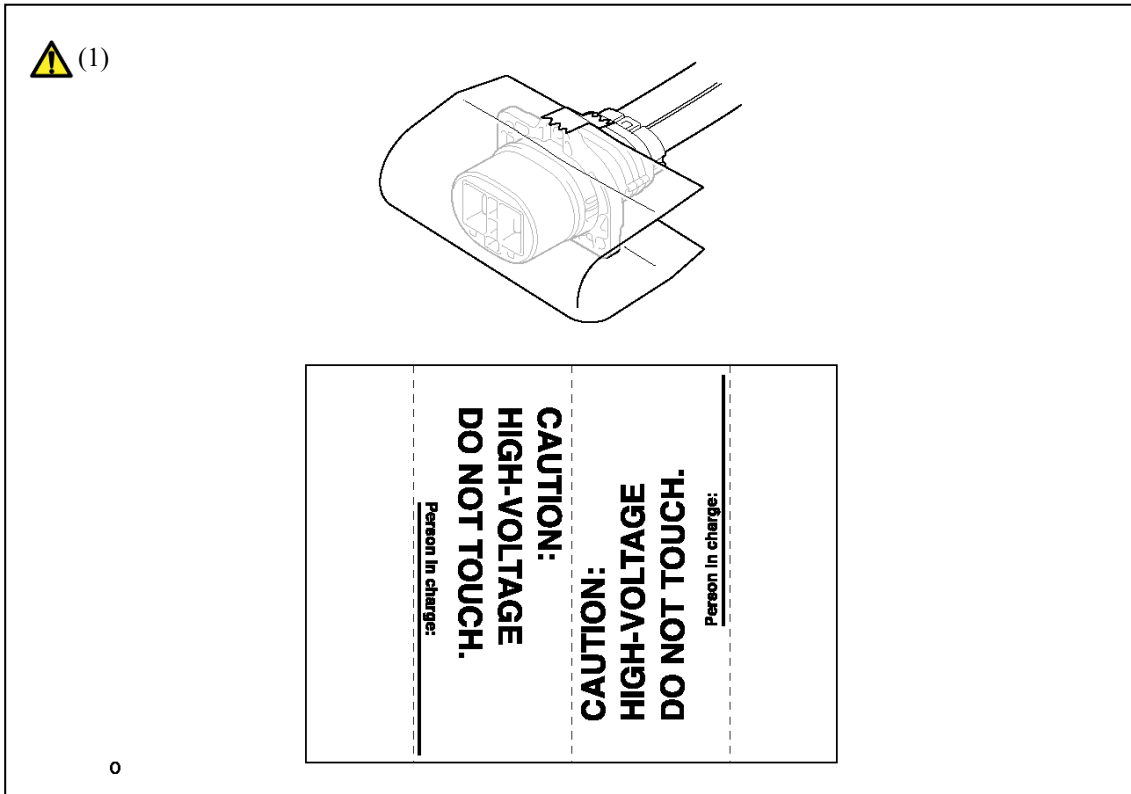

(1) Use the "CAUTION: HIGH VOLTAGE DO NOT TOUCH" sign to notify other technicians that the high-voltage system is being inspected and/or repaired.

Notice:

Be careful not to touch the terminal before or during attaching the display label.

12. REMOVE CONNECTOR COVER ASSEMBLY

	<p>CAUTION: Wear insulated gloves.</p> <p>NOTICE:</p> <ul style="list-style-type: none">• Make sure to pull the connector cover assembly straight up, as a connector is connected to the bottom of the cover.• Do not touch the connector cover assembly waterproofing rubber.• Do not allow any foreign matter or water to enter the inverter with converter assembly.
---	--

a.

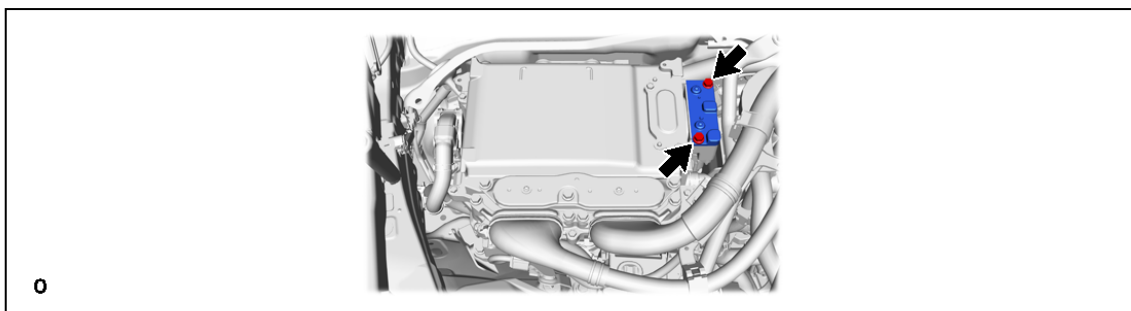

13. CHECK TERMINAL VOLTAGE

	CAUTION: Wear insulated gloves.
	NOTICE: Do not allow any foreign matter or water to enter the inverter with converter assembly.

a.

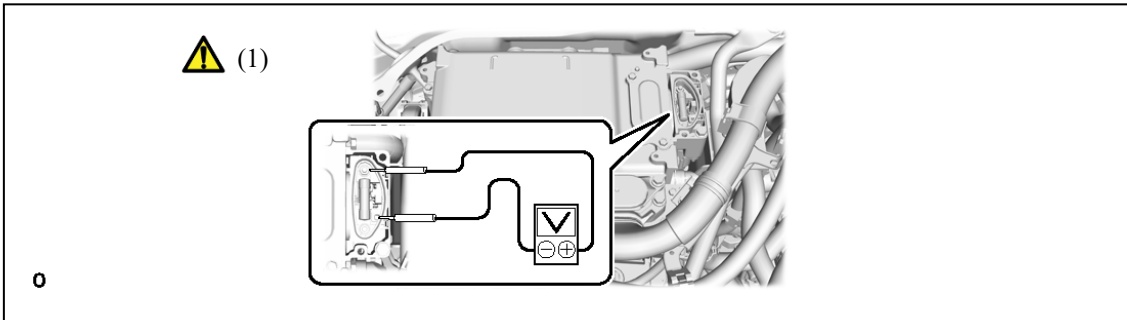

(1) Using a voltmeter, measure the voltage between the terminals of the 2 phase connectors.

Standard Voltage:

0 V

Hint:

Use a measuring range of DC 750 V or more on the voltmeter.

14. INSTALL CONNECTOR COVER ASSEMBLY

	CAUTION: Wear insulated gloves.
	NOTICE: <ul style="list-style-type: none">• Visually confirm that the connector cover assembly waterproofing rubber is securely installed before installing the connector cover assembly.• Do not touch the connector cover assembly waterproofing rubber.• Make sure that the interlock is fully engaged.

a.

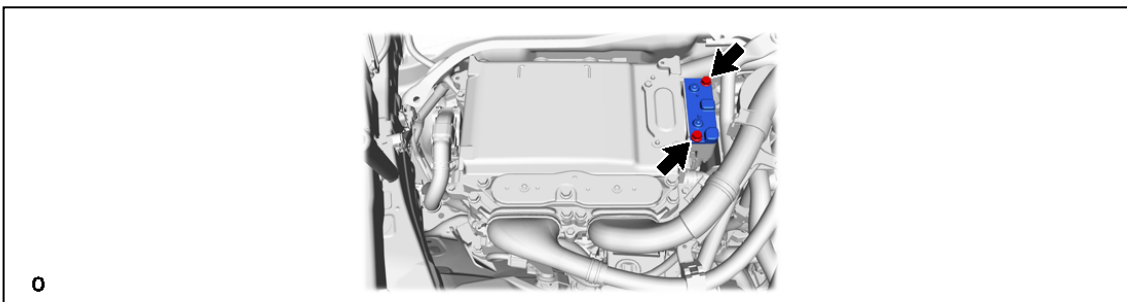

15. REMOVE LUGGAGE COMPARTMENT MAT SUB-ASSEMBLY

a.

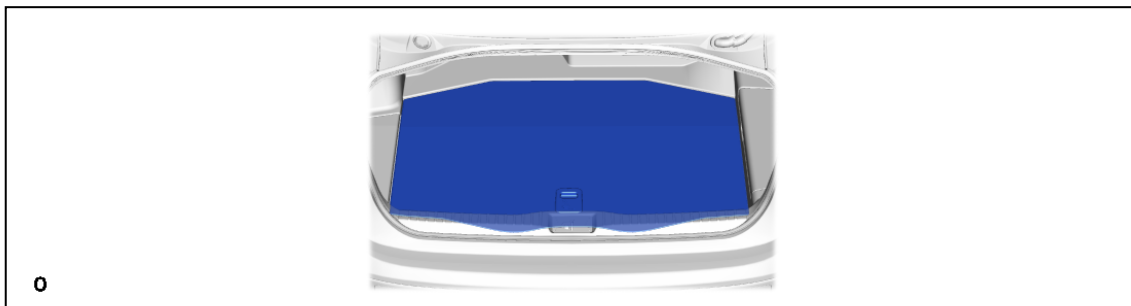

16. REMOVE LUGGAGE COMPARTMENT TRIM COVER LH

a.

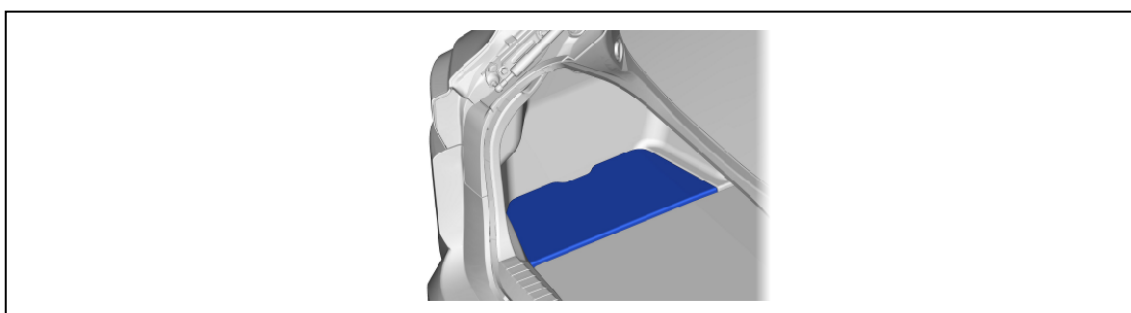

17. REMOVE TOOL BOX

a.

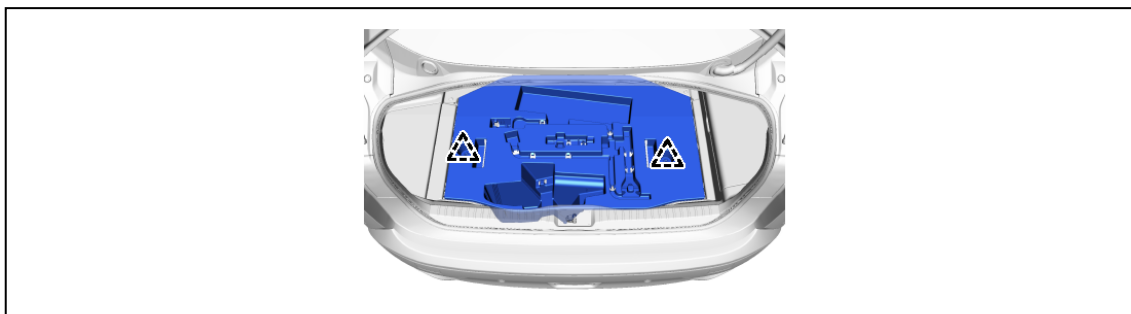

18. REMOVE FRONT LUGGAGE COMPARTMENT TRIM COVER

a.

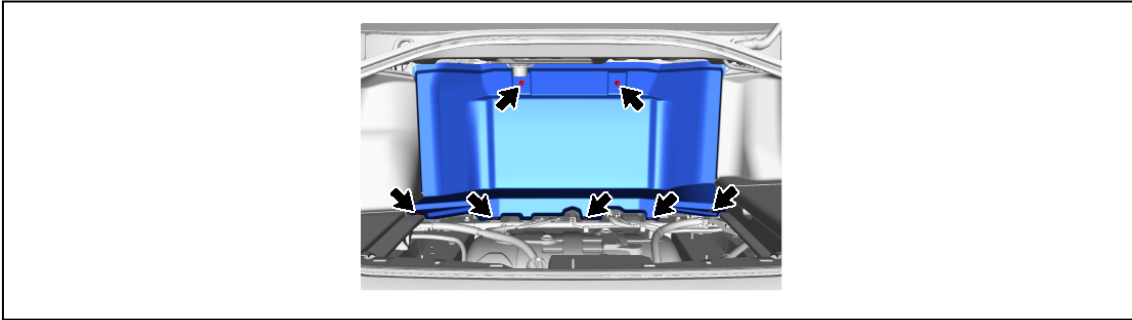

19. REMOVE REAR FLOOR FINISH PLATE

a.

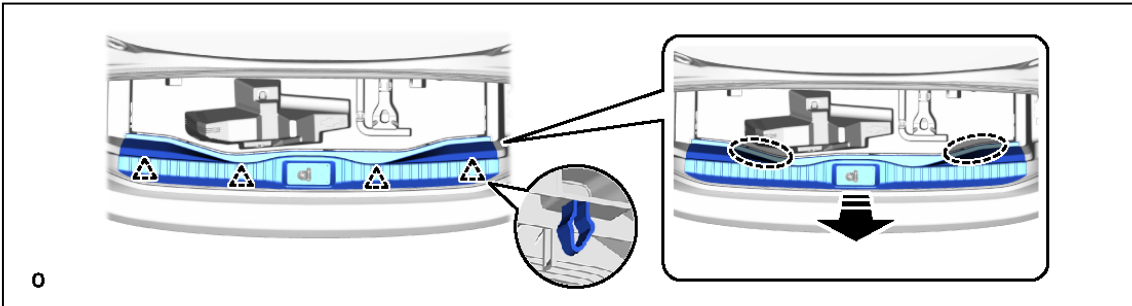

20. REMOVE LUGGAGE COMPARTMENT TRIM COVER INNER LH

a.

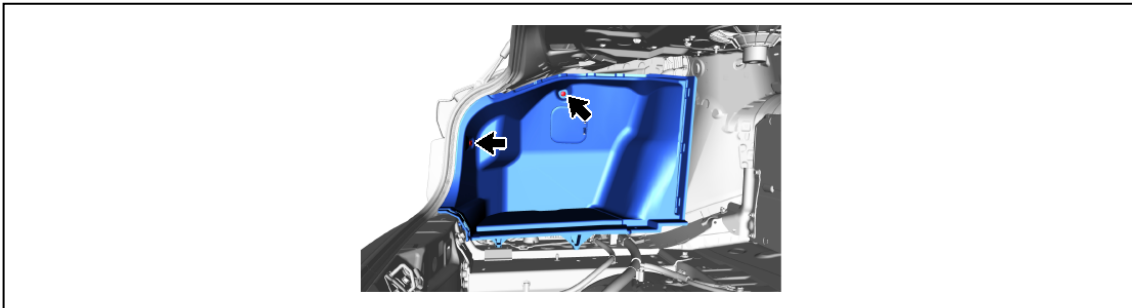

21. REMOVE LUGGAGE COMPARTMENT TRIM COVER INNER RH

a.

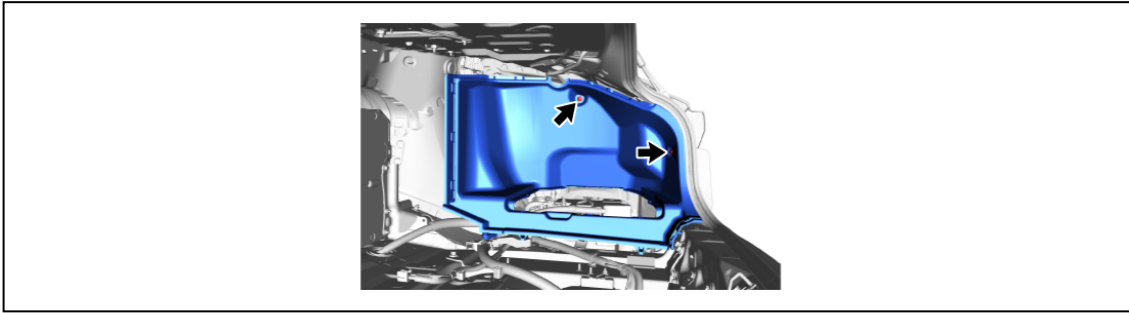

22. REMOVE REAR DOOR SCUFF PLATE INSIDE LH

a.

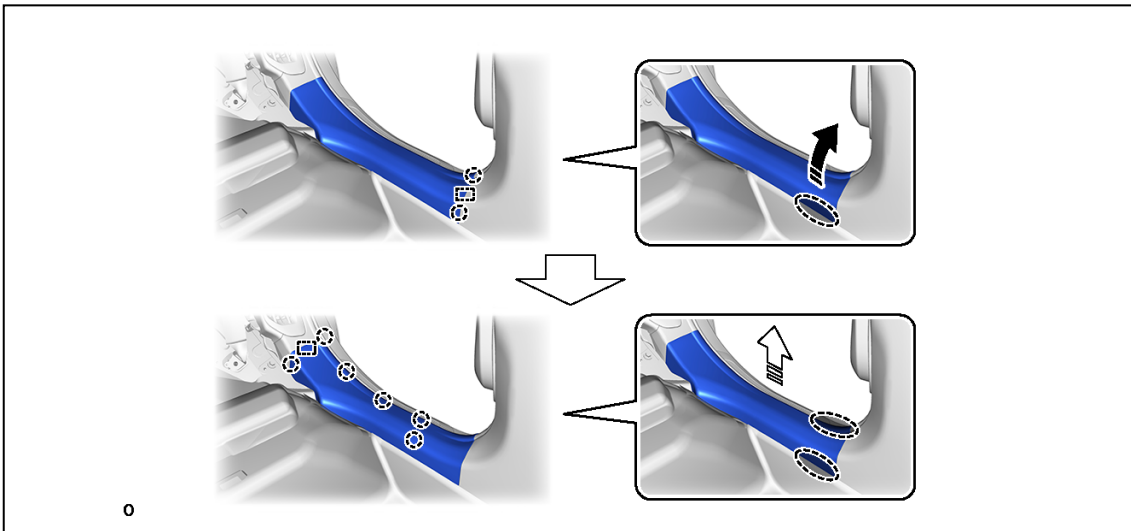

	Place Hands Here		Remove in this Direction (1)
	Remove in this Direction (2)	-	-





23. REMOVE REAR DOOR SCUFF PLATE INSIDE RH

a. Use the same procedure described for the LH side.

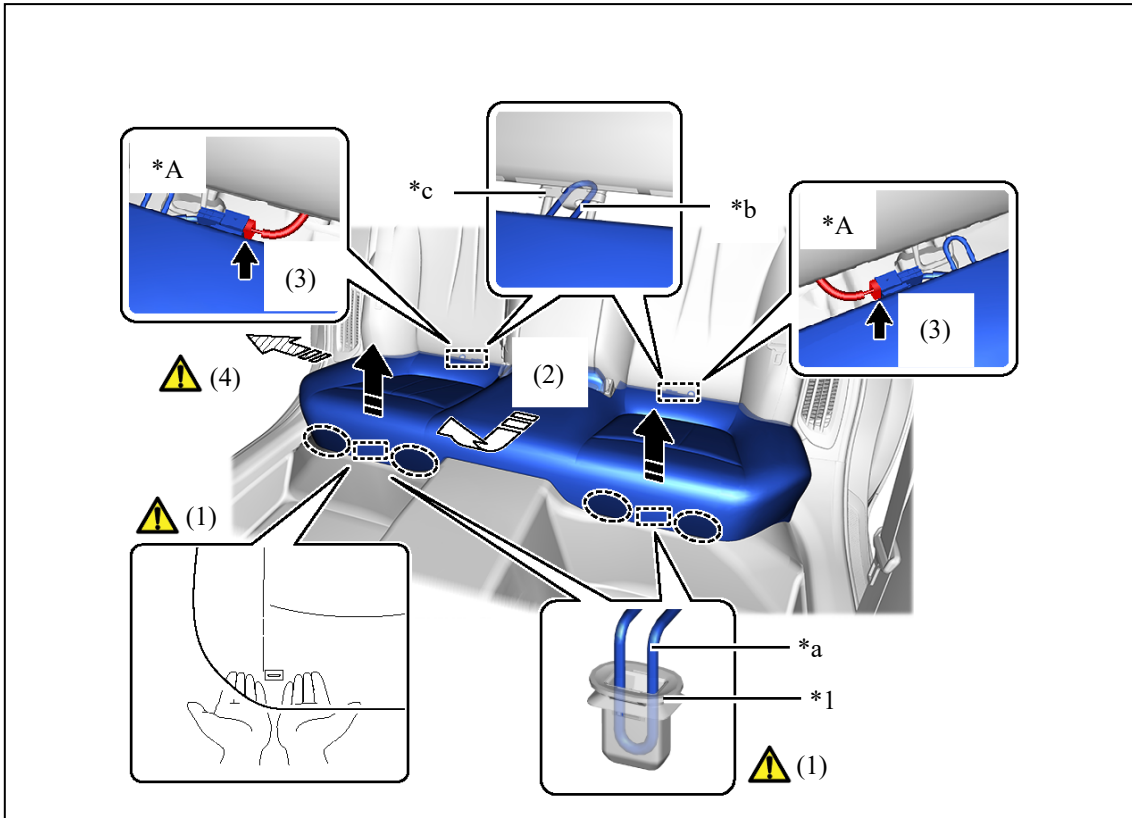
24. REMOVE BENCH TYPE REAR SEAT CUSHION ASSEMBLY

a.



*A	w/ Seat Heater System	-	-
*1	Rear Seat Cushion Lock Hook	-	-
*a	Front Hook	*b	Rear Hook
*c	Seatback Frame	-	-
	Place Hands Here		Remove in this Direction (1)
	Remove in this Direction (2)		Carry out in this Direction

- (1) Place your hand in the position beside the front hook as shown in the illustration and lift the front end of bench type rear seat cushion assembly in the removal direction (1) to detach the front hook from the rear seat cushion lock hook.

Notice:

Be sure to detach the front hook one at a time.

- (2) Pull in the removal direction (2) to detach the rear hook.
- (3) w/ Seat Heater System:
Disconnect the 2 connectors.
- (4) Remove and carry the bench type rear seat cushion assembly out of the vehicle as shown in the illustration.

25. REMOVE REAR SEAT CUSHION LOCK HOOK

a.

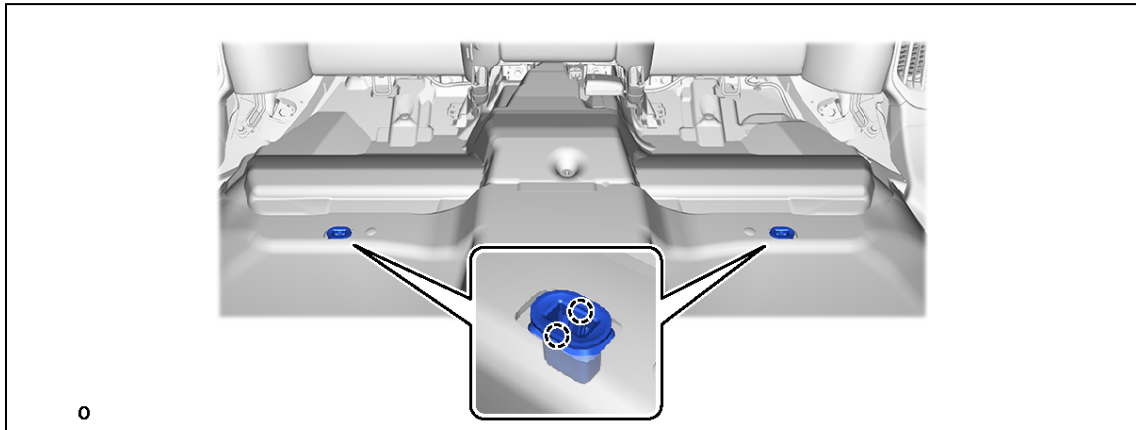

26. REMOVE BENCH TYPE REAR SEATBACK ASSEMBLY

a.

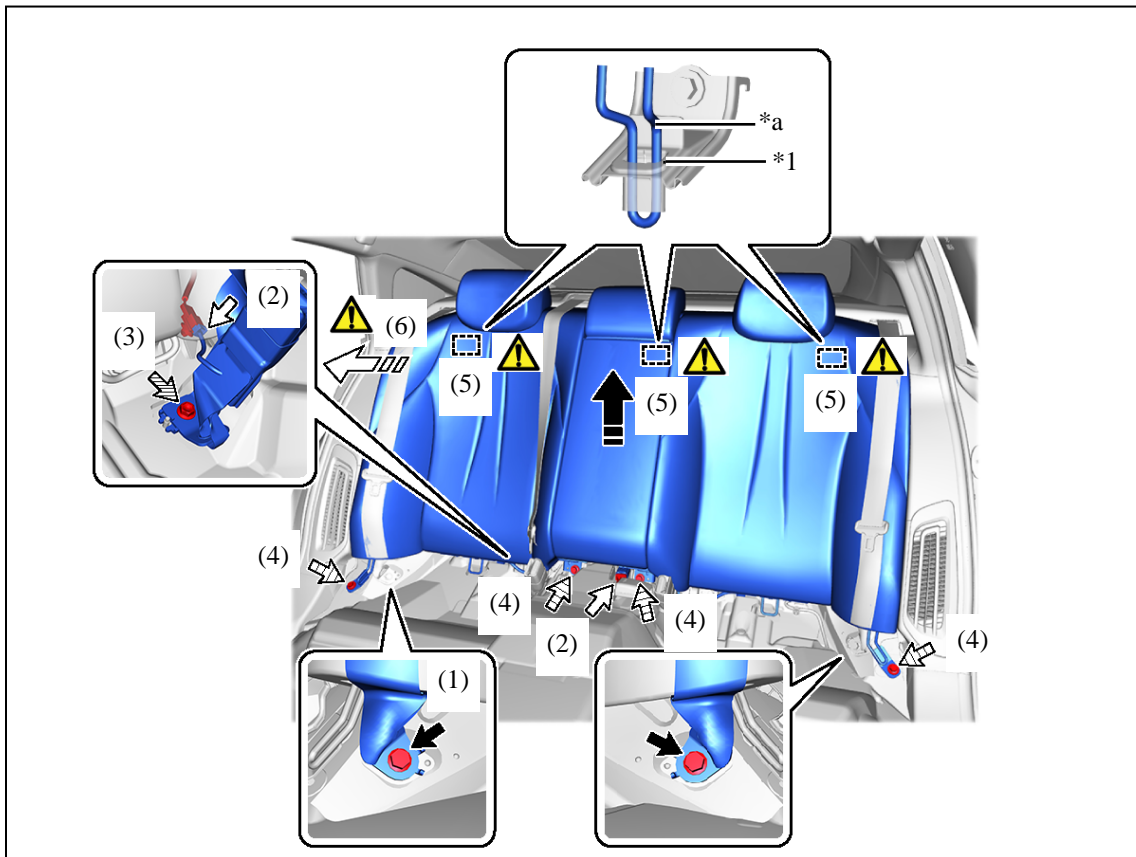

*1	Rear Seatback Holder	-	-
*a	Rear Hook	-	-
	Lift up in this Direction		Carry out in this Direction
	Bolt A		Connector
	Bolt B		Bolt C

- (1) Remove the 2 bolts A and floor anchor of the rear seat outer belt assembly RH and rear seat outer belt assembly LH.
- (2) Disconnect the 2 connectors.
- (3) Loosen the bolt B and remove the floor anchor of the rear seat inner with center belt assembly RH.
- (4) Remove the 4 bolts C.
- (5) Lift the bench type rear seatback assembly up as shown in the illustration to detach the rear hook from the rear seatback holder.
- (6) Remove and carry the bench type rear seatback assembly out of the vehicle as shown in the illustration.

Notice:

Carrying the bench type rear seatback assembly from the vehicle must be performed by multiple people.

27. REMOVE REAR SEATBACK HOLDER

a.

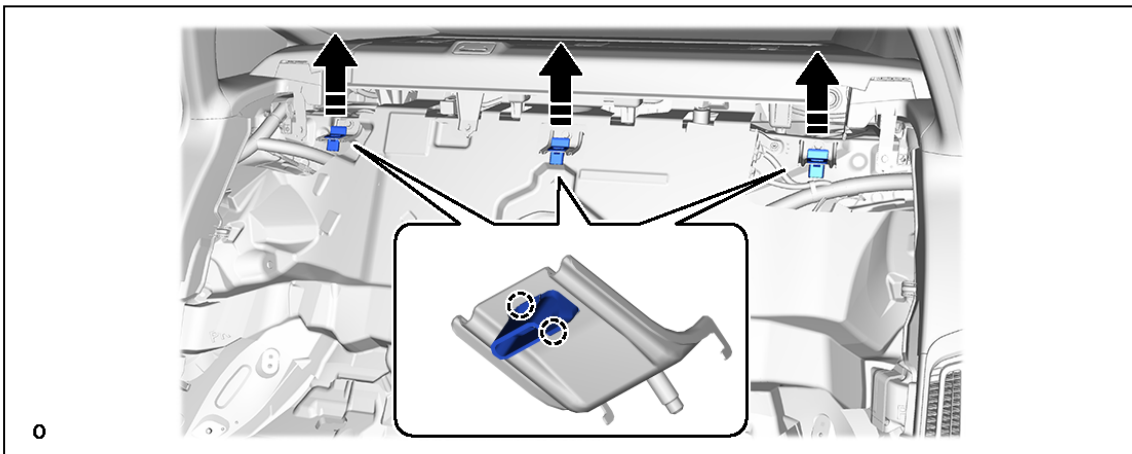

	Remove in this Direction	-	-
--	--------------------------	---	---

28. REMOVE REAR DOOR OPENING TRIM WEATHERSTRIP LH

a.

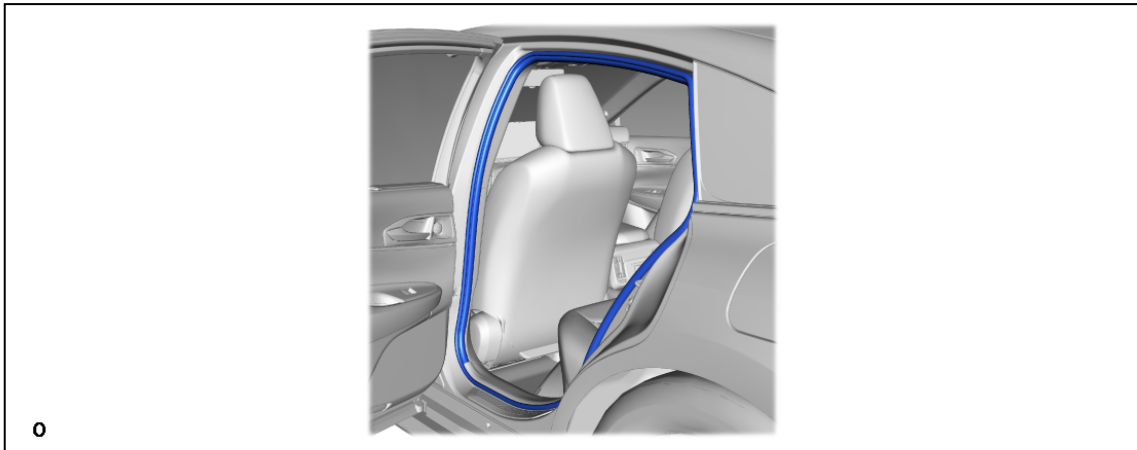



29. REMOVE REAR DOOR OPENING TRIM WEATHERSTRIP RH

a. Use the same procedure described for the LH side.

30. REMOVE REAR SEAT SIDE GARNISH LH

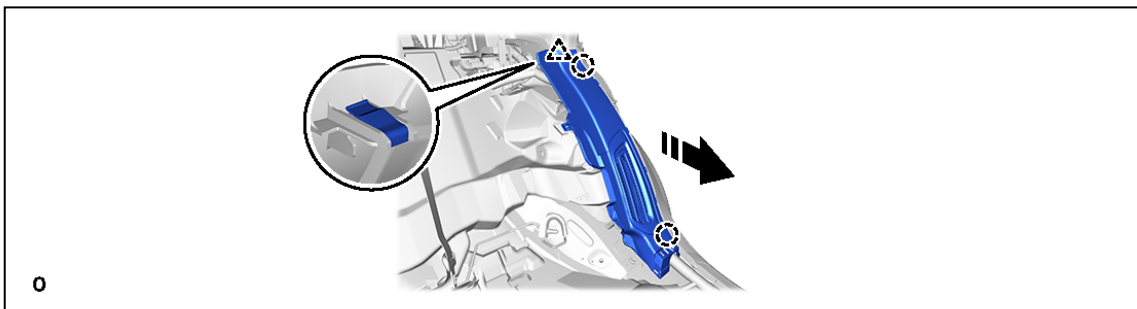
a.



	Remove in this Direction	-	-
---	--------------------------	---	---

31. REMOVE REAR SEAT SIDE GARNISH RH

a. Use the same procedure described for the LH side.

32. REMOVE NO. 1 ROOM PARTITION PAD

a.

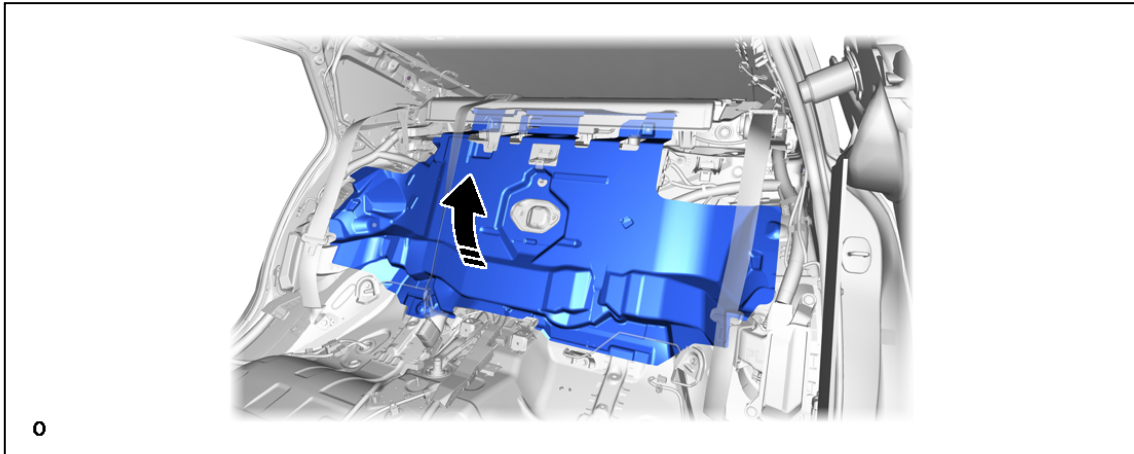

	Remove in this Direction	-	-
---	--------------------------	---	---

33. REMOVE NO. 2 EV BATTERY INTAKE DUCT

a.

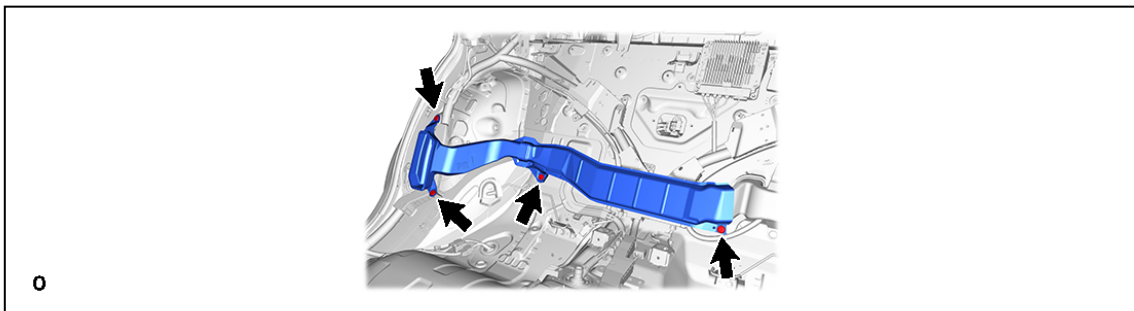

34. REMOVE NO. 4 EV BATTERY INTAKE DUCT

a.

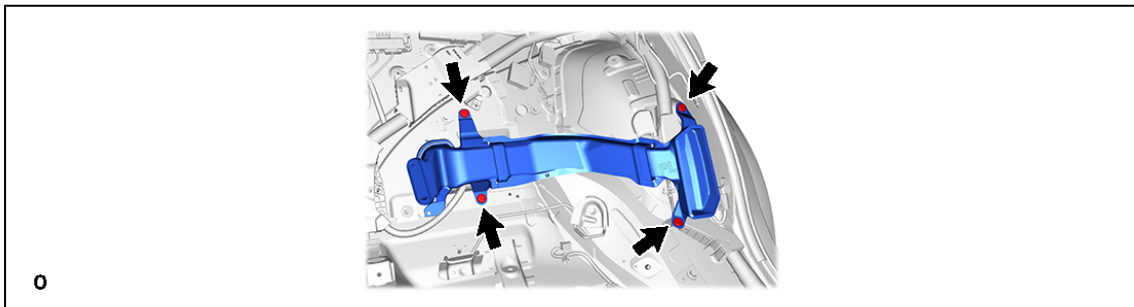

35. REMOVE CENTER NO. 2 FLOOR TO BRACE EXTENSION

a.

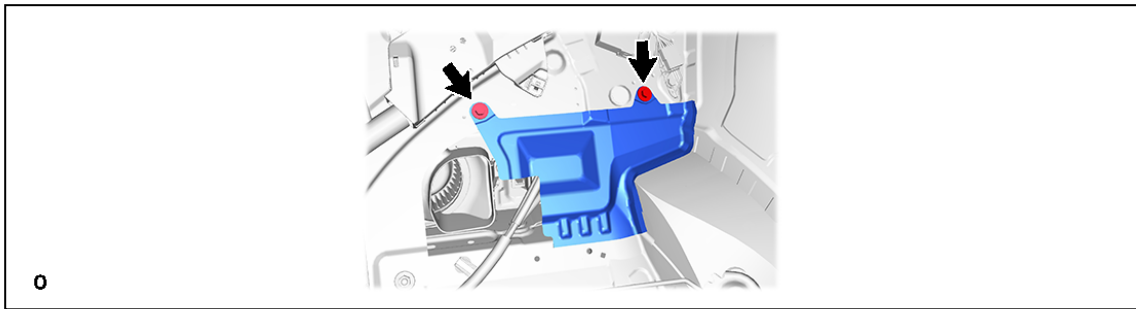

36. REMOVE NO. 2 EV BATTERY CLAMP COVER



CAUTION:
Wear insulated gloves.

a.

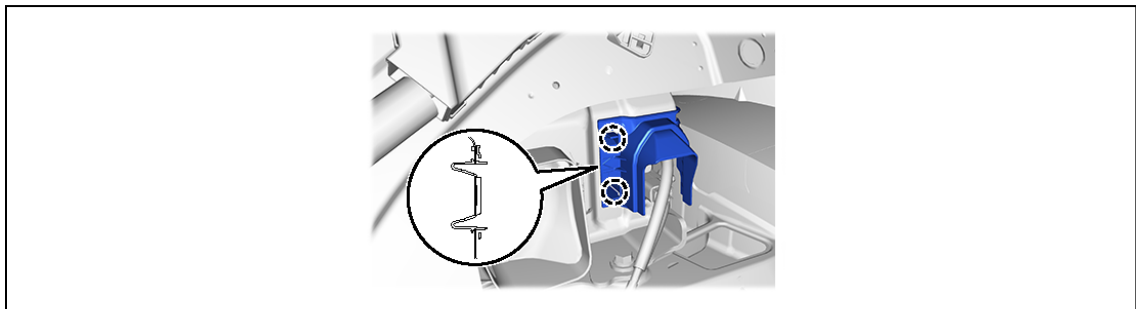

37. DISCONNECT FLOOR WIRE



CAUTION:
Wear insulated gloves.

a.

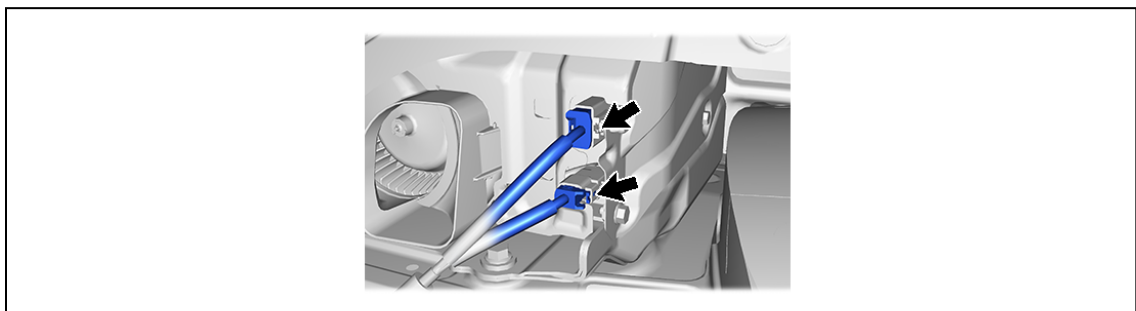

38. REMOVE CENTER NO. 1 FLOOR TO BLACE EXTENSION

a.

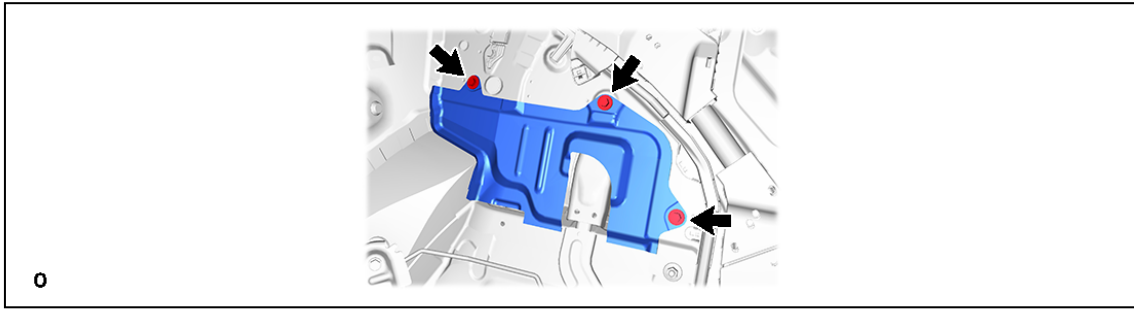

39. REMOVE BATTERY COVER LOCK STRIKER



CAUTION:
Wear insulated gloves.

a.

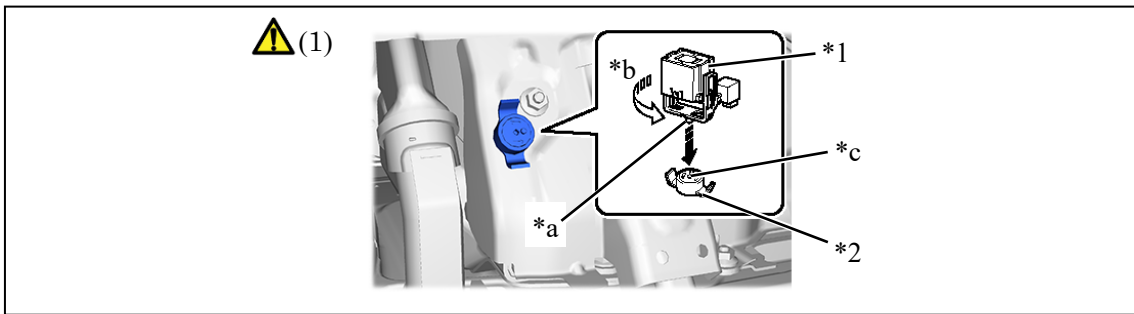

*1	Service Plug Grip	*2	Battery Cover Lock Striker
*a	Projection	*b	Turn
*c	Button	-	-

(1) Using the service plug grip, remove the battery cover lock striker.

Hint:

Insert the projection of the service plug grip and turn the button of the battery cover lock striker counterclockwise to release the lock.

40. REMOVE NO. 10 EV BATTERY SHIELD PANEL



CAUTION:
Wear insulated gloves.

a.

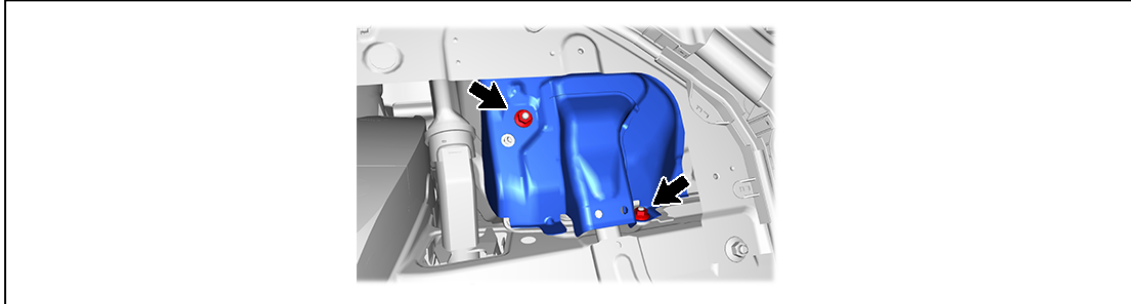

41. DISCONNECT FLOOR UNDER WIRE



CAUTION:
Wear insulated gloves.

a.

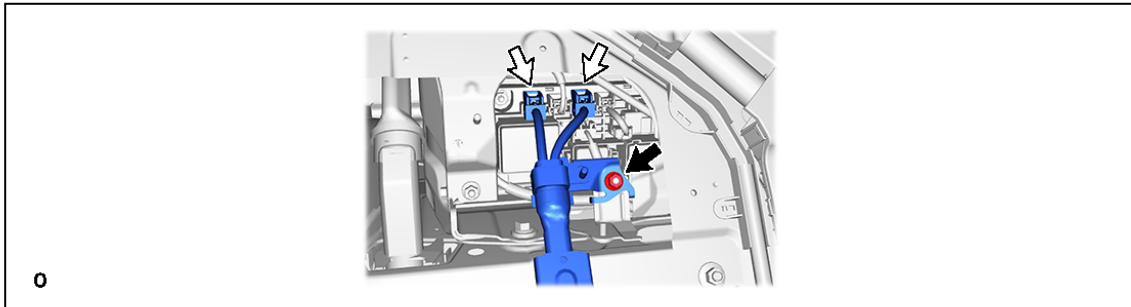

42. REMOVE NO. 4 EV BATTERY EXHAUST DUCT

a.

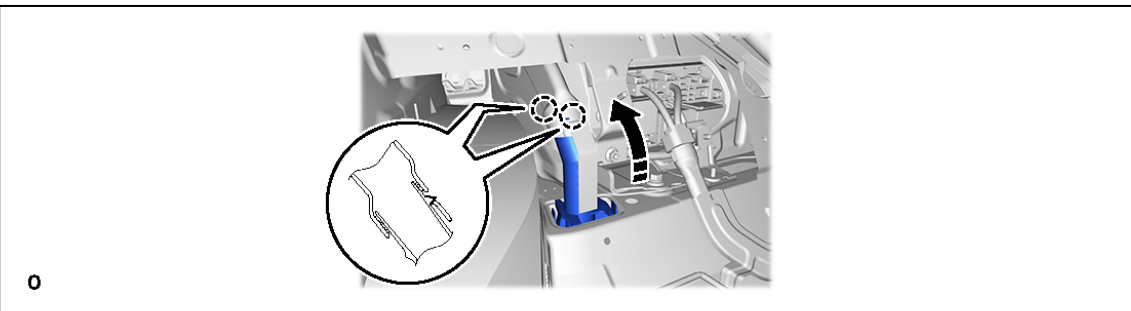

43. REMOVE STEREO COMPONENT AMPLIFIER ASSEMBLY WITH BRACKET

a.



44. REMOVE CLEARANCE WARNING ECU ASSEMBLY

a.

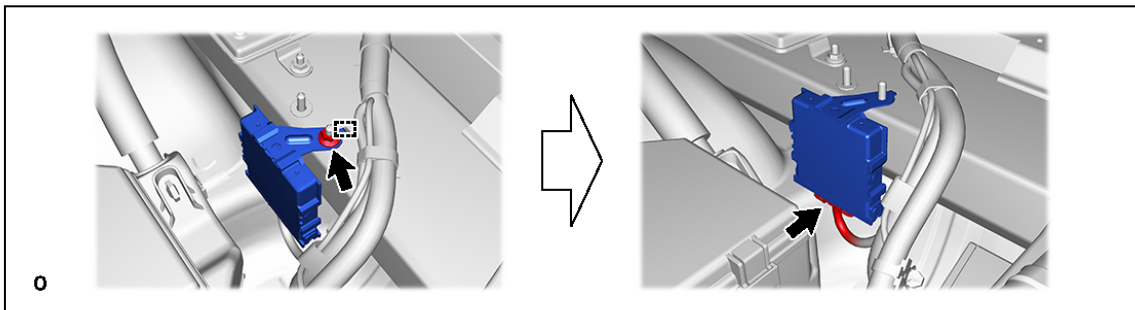

45. REMOVE NO. 3 INDOOR ELECTRICAL KEY ANTENNA ASSEMBLY

a.

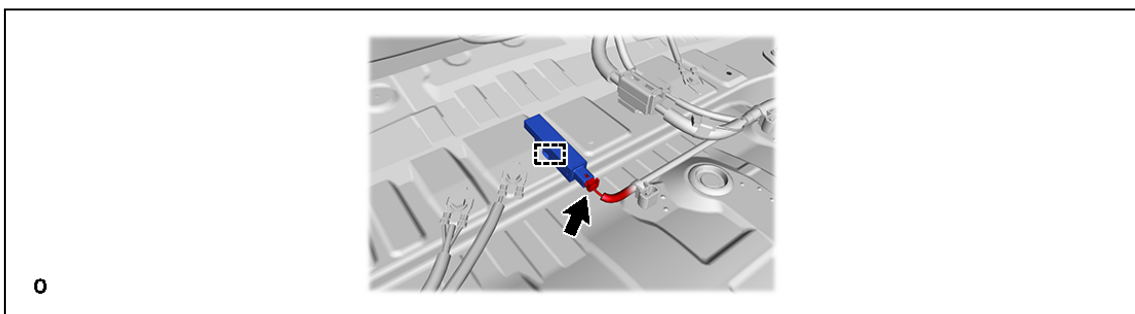

46. REMOVE SOCKET INVERTER WIRE (for 1500W Type)

	CAUTION: Wear insulated gloves.
---	--

a.

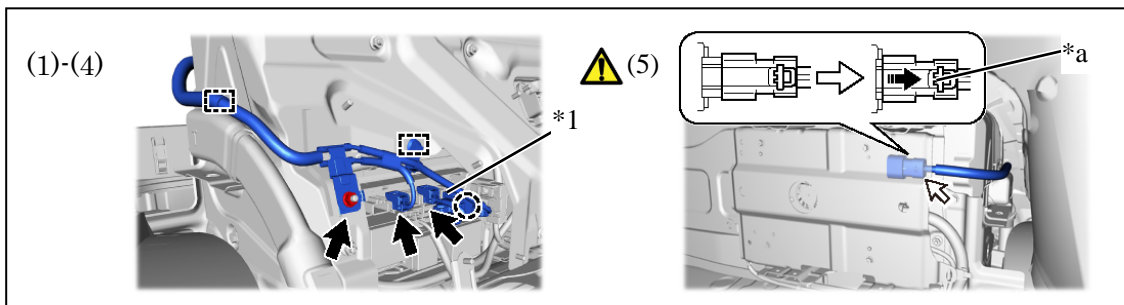

*1	Fuse Box	-	-
*a	Green-colored Lock	-	-
	Slide	-	-

- (1) Remove the nut.
- (2) Disconnect the each connectors.
- (3) Disengage the claw and disconnect the fuse box.
- (4) Disengage the clamp.
- (5) Using a screwdriver, slide the green-colored lock of the connector as shown in the illustration to release it and disconnect the socket inverter wire.

47. REMOVE NO. 1 LUGGAGE ROOM WIRE

a.

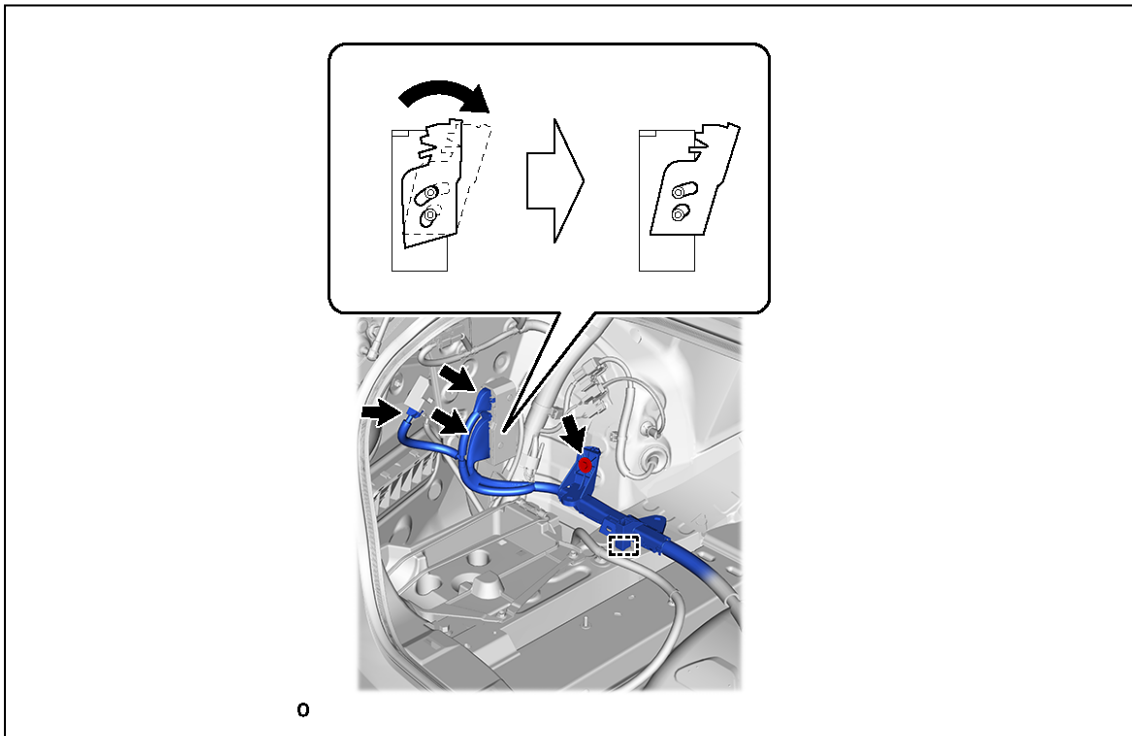

b.

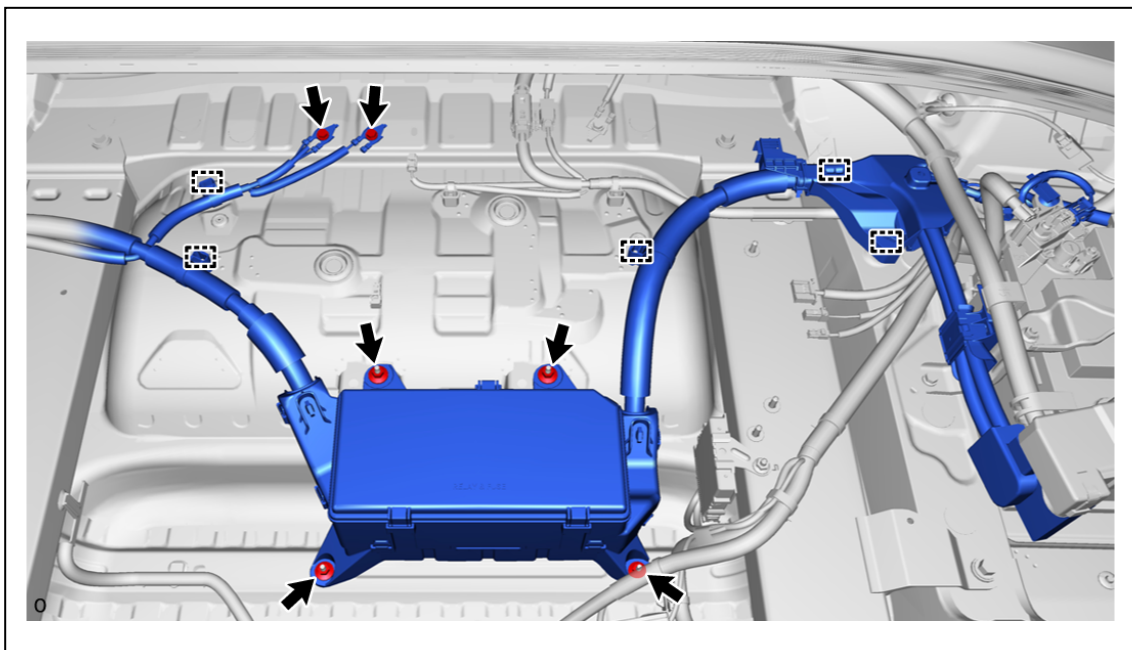

48. REMOVE FLOOR WIRE

a.

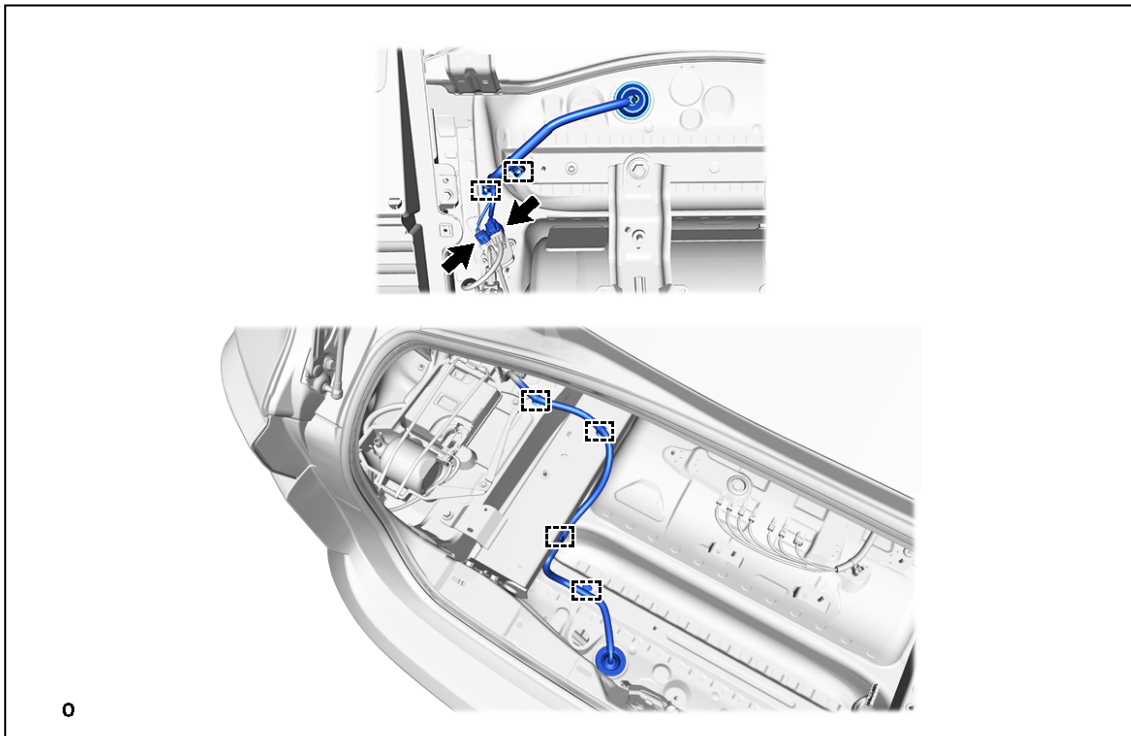

b.

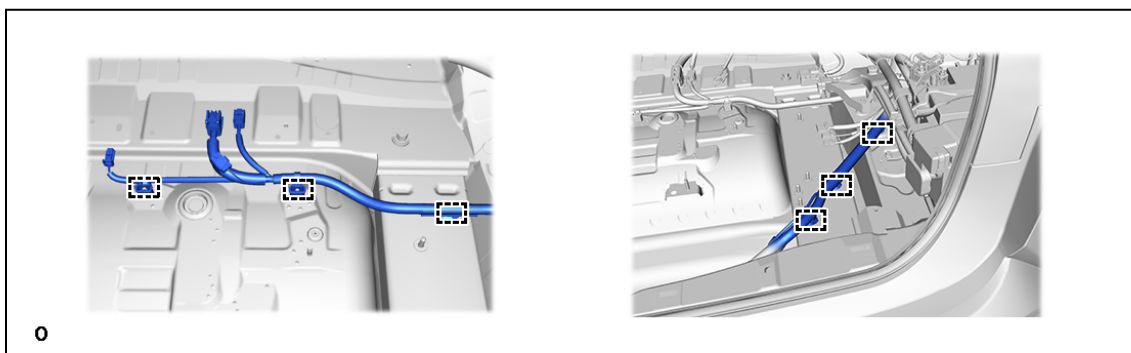

49. REMOVE VOLTAGE INVERTER



CAUTION:





Wear insulating gloves.

NOTICE:

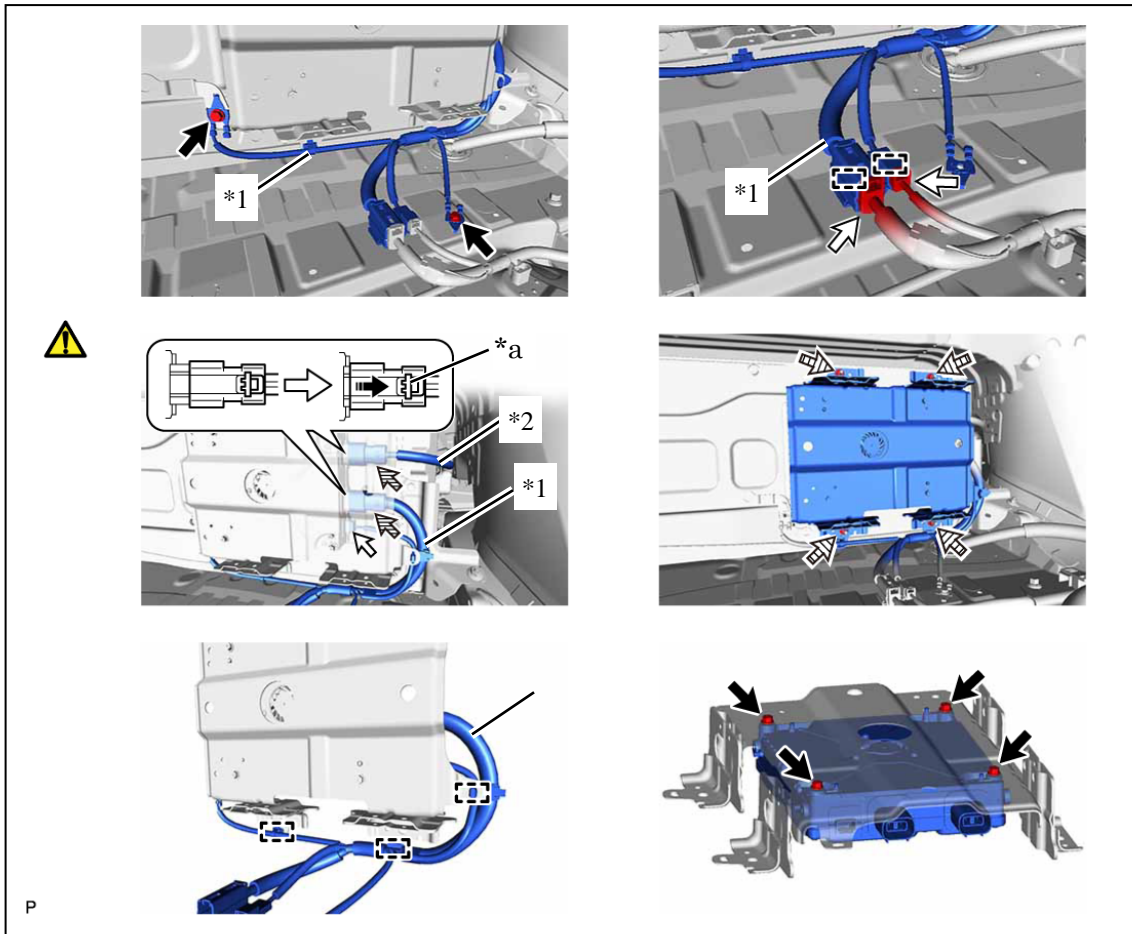
Insulate the separated high-voltage connector with insulating tape. At that time, wrap the insulating tape from the wire harness to the connector.

a.



*1	No. 2 Luggage Room Wire	*2	Socket Inverter Wire
*a	Green Lock	-	-
	Bolt		Connector
	High Voltage Connector		Nut
	Release Direction	-	-

- (1) Remove the 2 bolts.
- (2) Disconnect the 2 No. 2 luggage room wire connectors and detach the clamp.
- (3) Unlock the 2 high voltage connectors green lock as shown and disconnect the No. 2 luggage room wire high voltage connector and the socket inverter wire high voltage connector.
- (4) Disconnect the No. 2 luggage room wire connector.
- (5) Remove the 4 nuts and upper inverter cover from the voltage inverter bracket.
- (6) Detach the clamp and remove the No. 2 luggage room wire from the upper inverter cover.
- (7) Remove the 4 bolts and voltage inverter from the upper inverter cover.

50. REMOVE VOLTAGE INVERTER BRACKET

a.

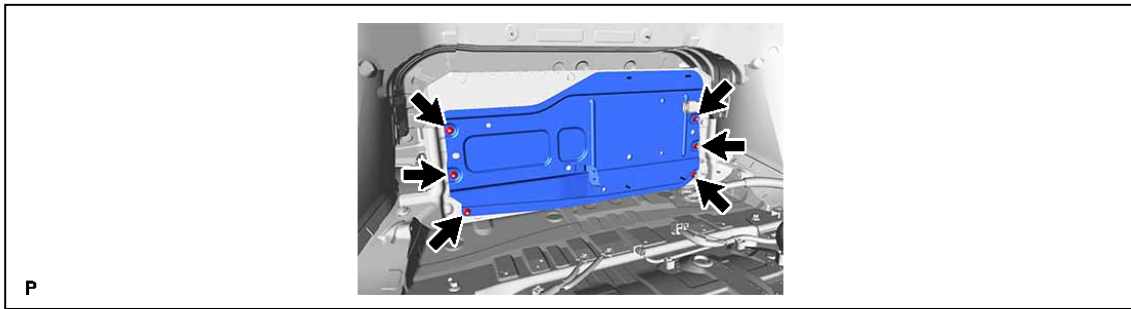

51. REMOVE EV BATTERY BRACKET LH



CAUTION:
Wear insulated gloves.

a.

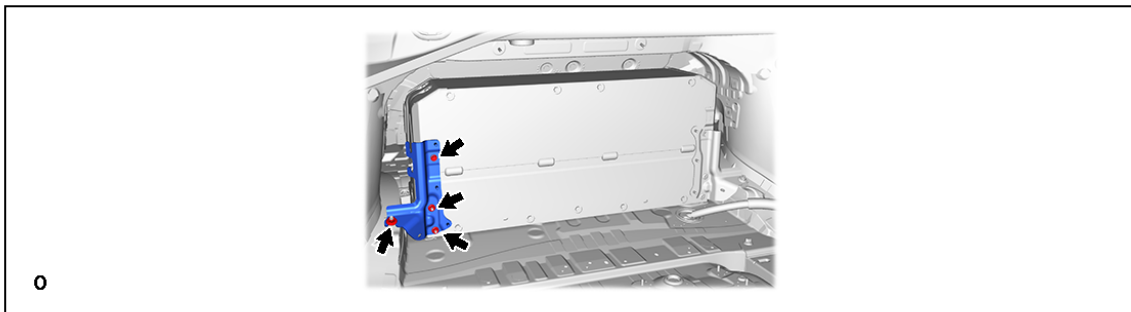

52. REMOVE EV BATTERY BRACKET RH



CAUTION:
Wear insulated gloves.

a.

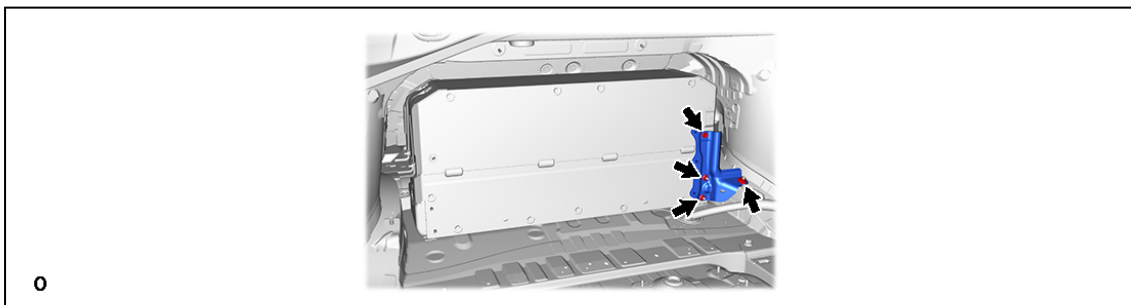

53. REMOVE EV SUPPLY BATTERY ASSEMBLY



CAUTION:
Wear insulated gloves.

a.

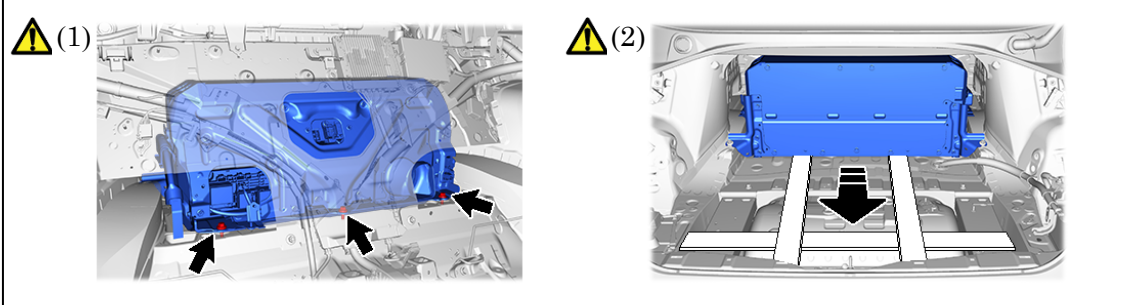

(1) Remove the 3 bolts.

Notice:

Do not allow foreign matter, such as grease or oil, to adhere to the bolts of the EV supply battery assembly.

(2) Place wooden blocks as shown in the illustration and install the EV supply battery assembly by sliding it on the wooden blocks.

Notice:

- To prevent the wire harness from being caught, make sure to bundle the wire harness using insulating tape or equivalent.
- Since the EV supply battery assembly is very heavy, 2 people are needed to remove it.
- When removing/moving the EV supply battery assembly, make sure not to tilt it more than 80°.
- When removing the EV supply battery assembly from the vehicle, do not allow it to contact the vehicle.
- Insulate the disconnected terminals or connectors with insulating tape.

54. REMOVE EV BATTERY DUCT SUB-ASSEMBLY



CAUTION:
Wear insulated gloves.

a.

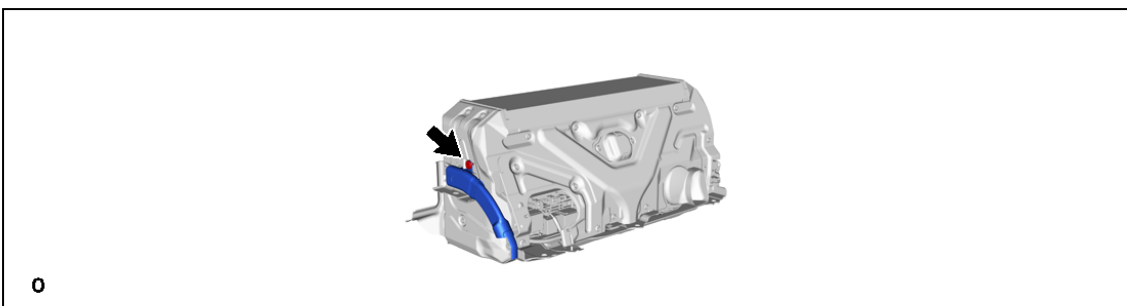

o

55. REMOVE NO. 9 EV BATTERY SHIELD PANEL



CAUTION:
Wear insulated gloves.

a.

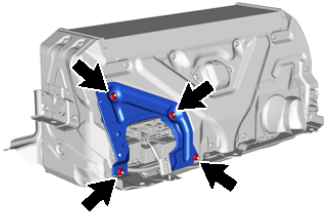

o

Removal of Hydrogen Tank

The following 3 pages contain general instructions for use when working on a MIRAI.
Read these instructions before proceeding to the hydrogen tank removal instructions on page 118.

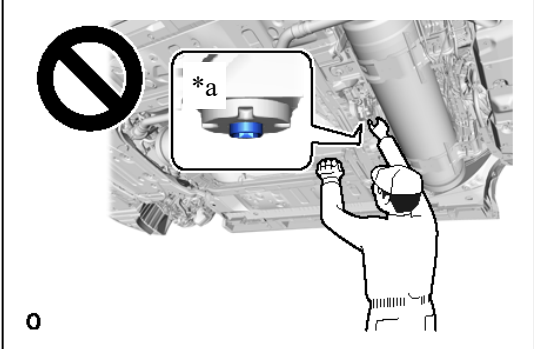
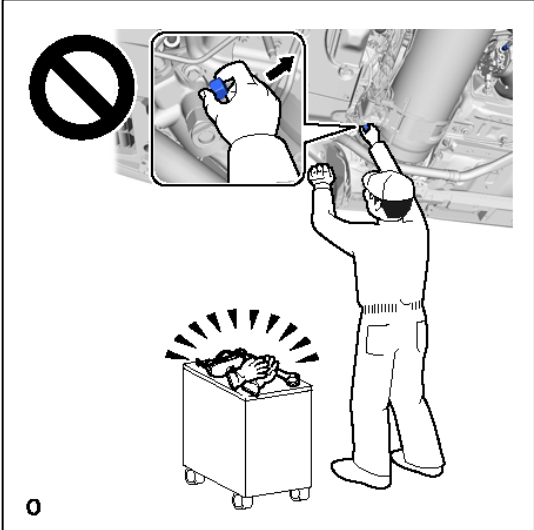
	<p>CAUTION:</p> <ul style="list-style-type: none">• Do not perform depressurization procedures when the manual valve of the hydrogen tank assembly is open.• The highly pressurized hydrogen gas inside the hydrogen tank assembly could blow out, resulting in a serious accident.• When performing depressurization, do not perform procedures by hand without wearing protective glasses and gloves.• The highly pressurized hydrogen gas inside the hydrogen tank assembly could blow out, resulting in a serious accident.	 <p>o</p> <table border="1" data-bbox="813 873 1348 929"><tr><td>*a</td><td>Manual Valve Open</td></tr></table>	*a	Manual Valve Open
	*a	Manual Valve Open		
 <p>o</p>				



- After performing depressurization procedures, when first loosening the union nut of the high pressure hydrogen piping, do not loosen the union nut by hand without wearing protective glasses and gloves.
- Even when depressurization procedures are performed, the pressurized hydrogen gas inside the high pressure hydrogen piping cannot be completely depressurized, so the highly pressurized hydrogen gas remaining in the high pressure hydrogen piping could blow out, resulting in a serious accident.
- Because the hydrogen tank assembly is extremely heavy, make sure to follow the work procedures described in the repair manual.
- If work is not performed according to the procedures described in the repair manual, there is a danger that the engine lifter could drop and components could fall down.

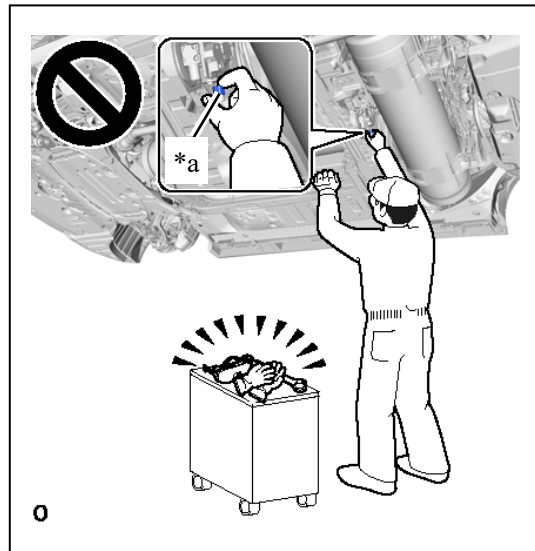

*a After depressurization procedures, the high pressure piping union nut that is loosened first

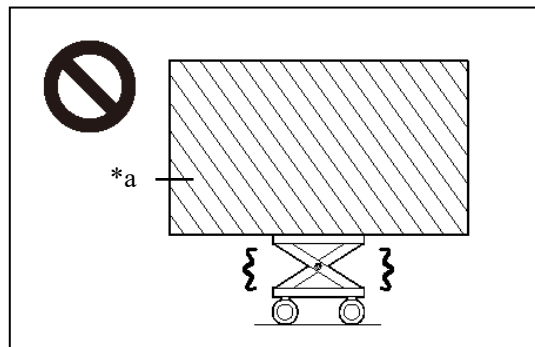

*a Heavy load exceeding the weight limits or size limits of the engine lifter



- When hoisting up the hydrogen tank assembly, do not hoist it when not properly balanced.
- The hydrogen tank assembly could fall, resulting in a serious accident.

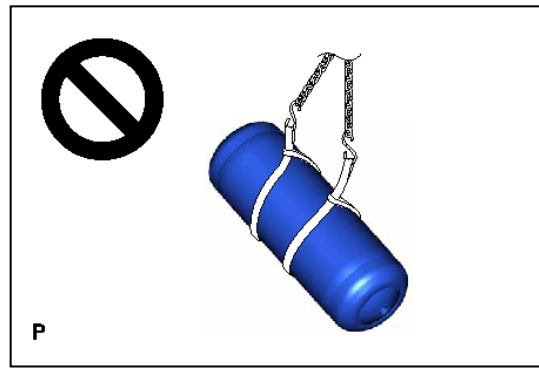



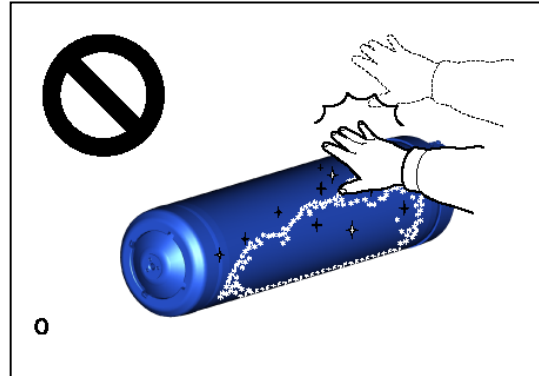

- When installing or removing a compressed hydrogen gas tank immediately after discharging compressed hydrogen gas, do not touch the tank or piping if there is frost on it.
- Touching the tank or piping while there is frost on it could result in burn-like injuries due to frostbite.

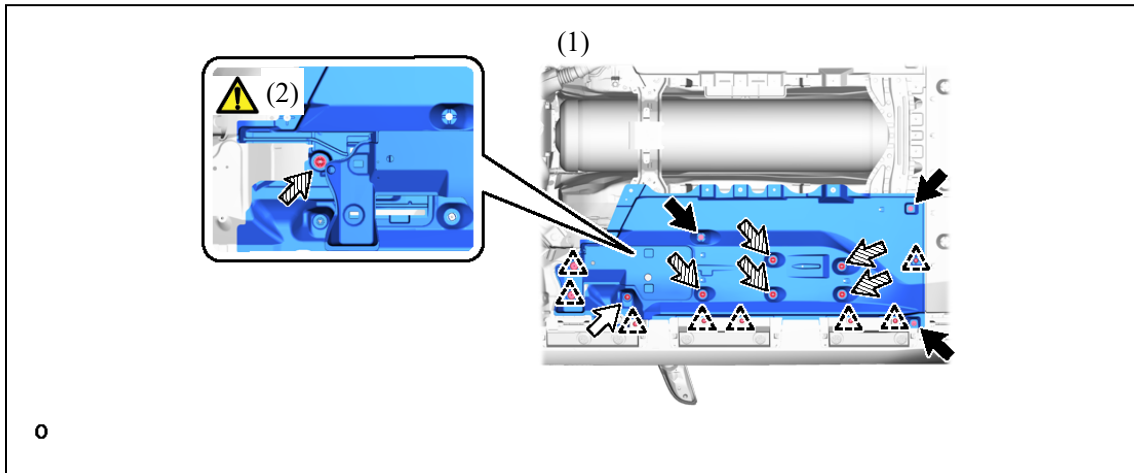

1. REMOVE NO. 1 FLOOR BOARD SUB-ASSEMBLY

a.



	Bolt		Nut
	Grommet	-	-

- (1) Remove the 3 bolts and nut, detach the 8 clips and loosen the 5 grommets.
- (2) Slide the cover and loosen the grommet and remove the No. 2 floor board sub-assembly.

2. REMOVE FRONT FLOOR BRACE SUB-ASSEMBLY CENTER

a.

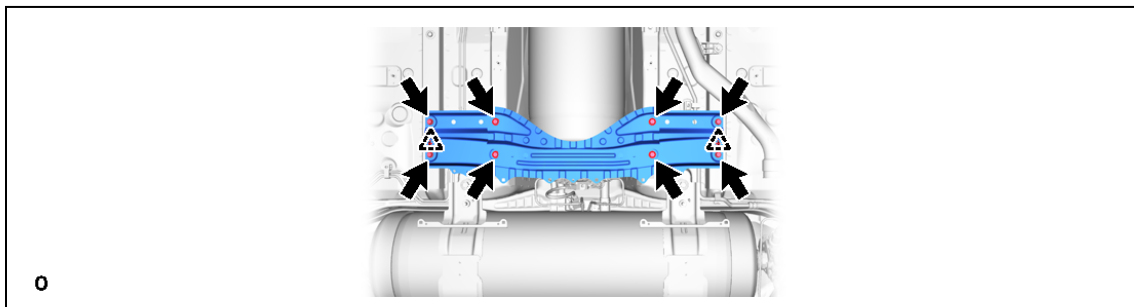

3. DISCONNECT NO. 2 HYDROGEN TANK TUBE

	<p>CAUTION:</p> <ul style="list-style-type: none">• After performing depressurization procedures, when first loosening the union nut of the high pressure hydrogen piping, do not loosen the union nut by hand without wearing protective glasses and gloves.• Even when depressurization procedures are performed, the pressurized hydrogen gas inside the high pressure hydrogen piping cannot be completely depressurized, so the highly pressurized hydrogen gas remaining in the high pressure hydrogen piping could blow out, resulting in a serious accident.
---	--

a.

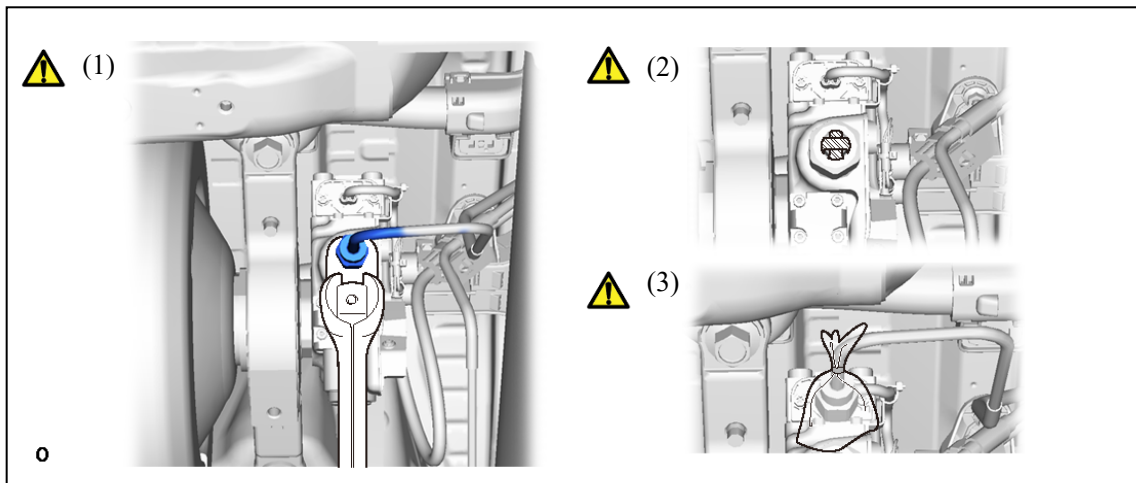

- (1) Using a 19 mm union nut wrench, loosen the union nut and disconnect the No. 2 hydrogen tank tube from the No. 1 hydrogen tank assembly.
- (2) To prevent contamination by foreign matter, cover the openings of the No. 1 hydrogen tank assembly with protective tape.
- (3) To prevent contamination by foreign matter, cover the connecting portions of the No. 2 hydrogen tank tube with plastic bags.

4. DISCONNECT NO. 5 HYDROGEN TANK TUBE

	<p>CAUTION:</p> <ul style="list-style-type: none">• After performing depressurization procedures, when first loosening the union nut of the high pressure hydrogen piping, do not loosen the union nut by hand without wearing protective glasses and gloves.• Even when depressurization procedures are performed, the pressurized hydrogen gas inside the high pressure hydrogen piping cannot be completely depressurized, so the highly pressurized hydrogen gas remaining in the high pressure hydrogen piping could blow out, resulting in a serious accident.
---	--

a.

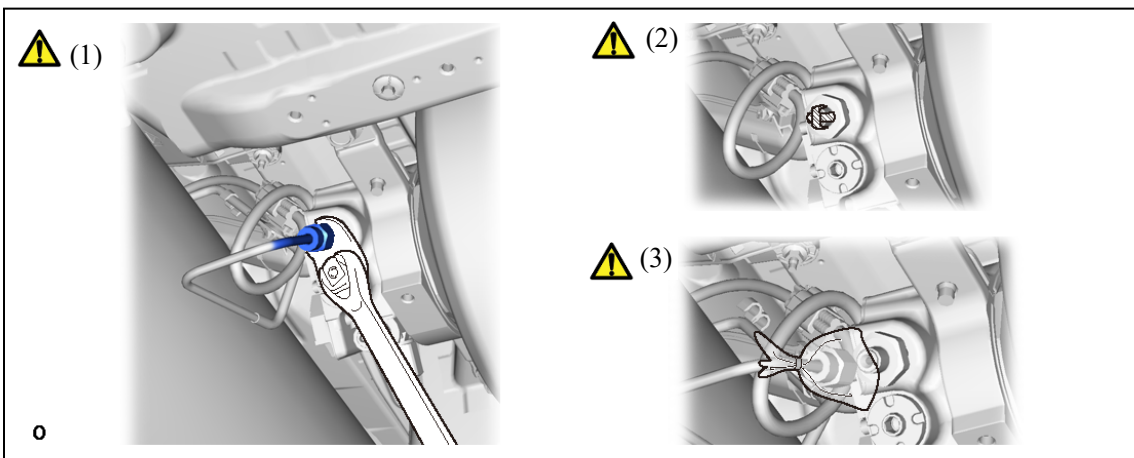

- (1) Using a 19 mm union nut wrench, loosen the union nut and disconnect the No. 5 hydrogen tank tube from the No. 1 hydrogen tank assembly.
- (2) To prevent contamination by foreign matter, cover the openings of the No. 1 hydrogen tank assembly with protective tape.
- (3) To prevent contamination by foreign matter, cover the connecting portions of the No. 5 hydrogen tank tube with plastic bags.

5. REMOVE NO. 1 HYDROGEN TANK ASSEMBLY

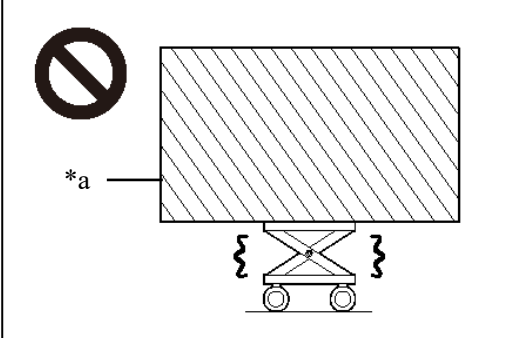
	<p>CAUTION:</p> <ul style="list-style-type: none"> • Because the hydrogen tank assembly is extremely heavy, make sure to follow the work procedures described in the repair manual. • If work is not performed according to the procedures described in the repair manual, there is a danger that the engine lifter could drop and components could fall down. 	<div style="border: 1px solid black; padding: 5px; margin-bottom: 5px;">  </div> <table border="1" style="width: 100%; border-collapse: collapse;"> <tr> <td style="width: 50px; text-align: center; vertical-align: middle;">*a</td> <td>Heavy load exceeding the weight limits or size limits of the engine lifter</td> </tr> </table>	*a	Heavy load exceeding the weight limits or size limits of the engine lifter
*a	Heavy load exceeding the weight limits or size limits of the engine lifter			

a.

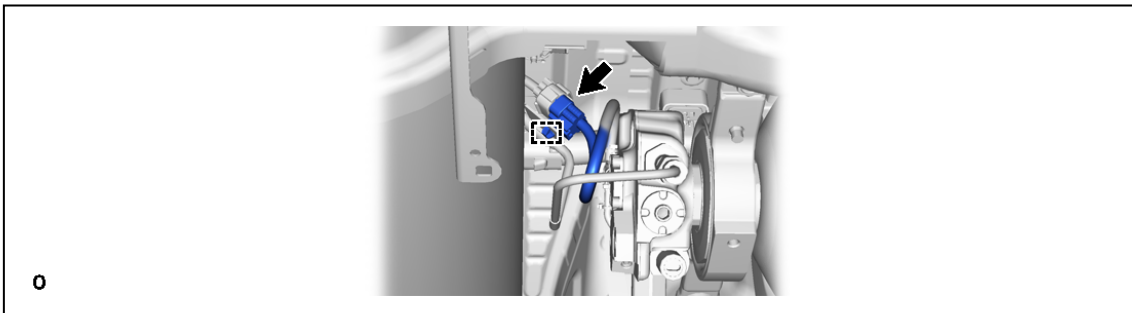

o

b.

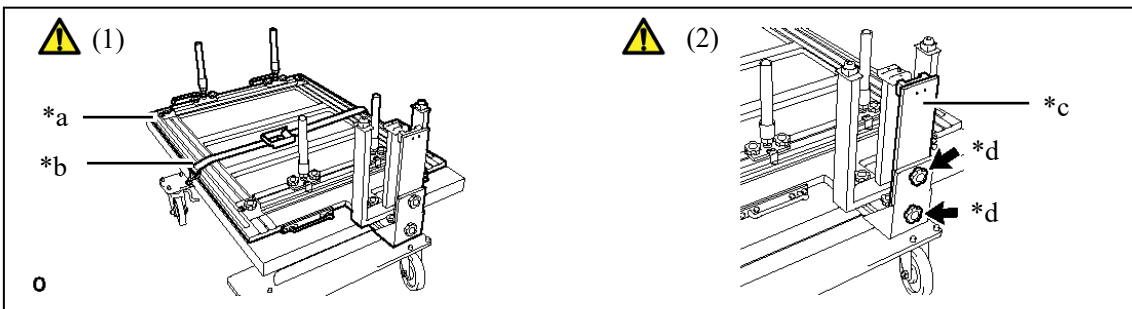

o

*a	SST (Hydrogen Tank Stand No. 2)	*b	Belt
*c	SST (Support No. 1)	*d	SST (Set Bolt A)

(1) Set SST (hydrogen tank stand No. 2) on the engine lifter and secure it with the belt.

SST

09403-62030

Notice:

Set SST (hydrogen tank stand No. 2) in the middle of the engine lifter and secure the center portion with the belt.

(2) Remove 2 SST (set bolt A) and SST (support No. 1).

SST

09403-62030 (09403-06200, 09403-06210)

c.

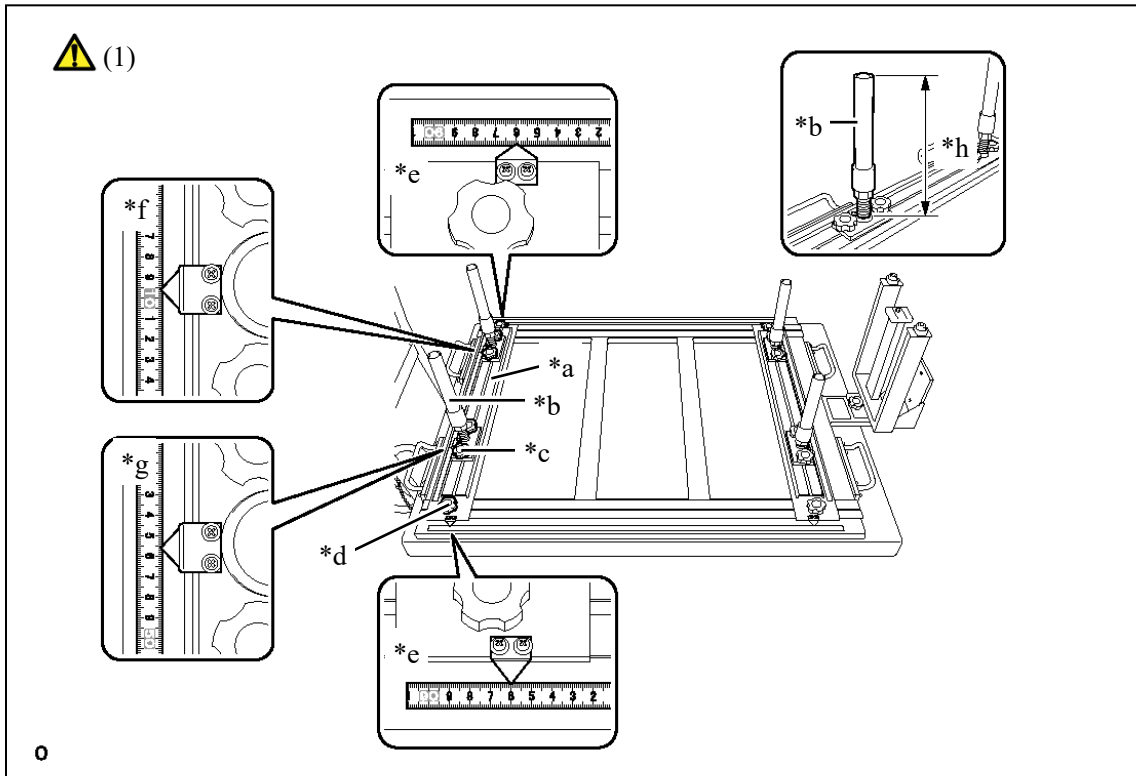

*a	SST (Support Rail No. 1)	*b	SST (Support No. 3)
*c	SST (Set Bolt C)	*d	SST (Set Bolt B)
*e	Scale surface: 860 mm (33.9 in.)	*f	Scale surface: 96 mm (3.78 in.)
*g	Scale surface: 156 mm (6.14 in.)	*h	Scale surface: 265 mm (10.4 in.)

(1) Adjust SST (support No. 3), SST (support rail No. 1), and tighten SST (set bolt B), SST (set bolt C).

SST

09403-62030 (09403-06230, 09403-06240, 09403-06250, 09403-06260)

Hint:

This is done to align SST (hydrogen tank stand No. 2) with the installation condition of the No. 1 hydrogen tank assembly on the vehicle.

d.

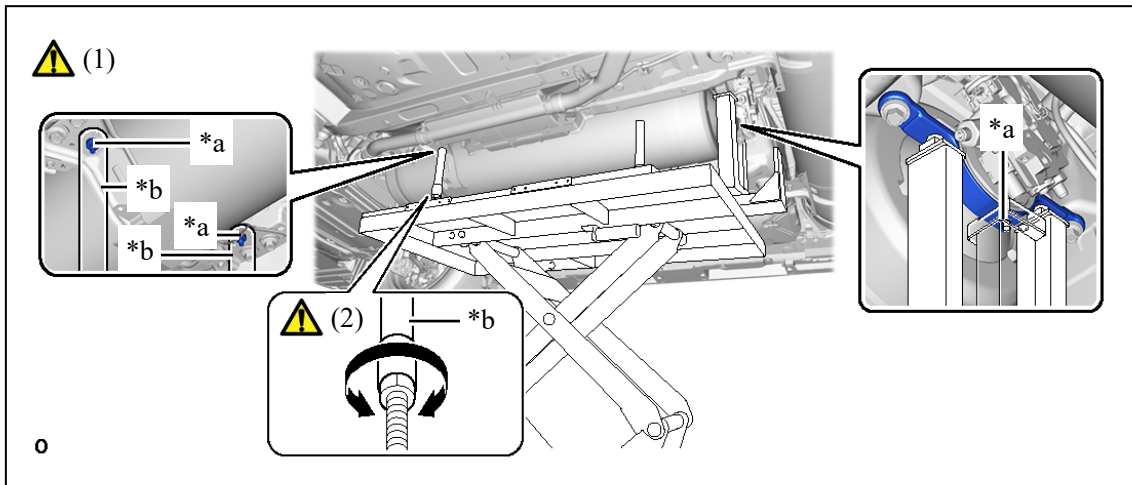

*a	Protrusion	*b	SST (Support No. 3)
----	------------	----	---------------------

- (1) Operate the engine lifter, and set SST (hydrogen tank stand No. 2) against the No. 1 hydrogen tank assembly.

Notice:

- The rear side SST (support No. 3) is not used. Therefore, put it between the No. 1 hydrogen tank assembly and body.
- Align the protrusions of each No. 1 hydrogen tank frame sub-assembly with the holes of SST (support No. 3).
- Align the protrusion of SST (support No. 2) with the hole of the lower hydrogen tank bracket.

- (2) When the gap between the No. 1 hydrogen tank frame sub-assembly and SST (support No. 3) is large, rotate SST (support No. 3) to adjust the height.

e.

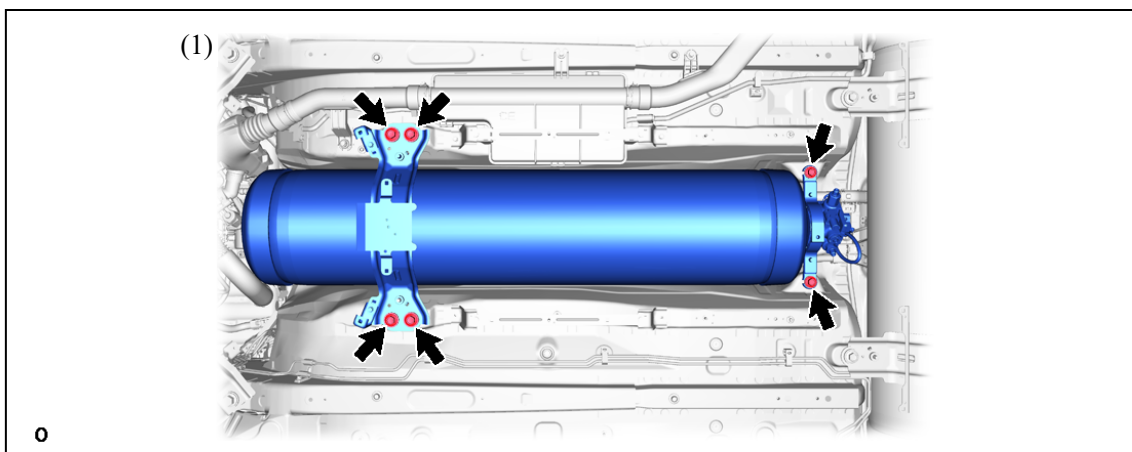

- (1) Remove the 6 bolts.
- (2) Operate the engine lifter and slowly remove the No. 1 hydrogen tank assembly from the vehicle.

Notice:

Make sure that the No. 1 hydrogen tank assembly does not interfere with the hydrogen tank tube.

6. REMOVE FRONT HYDROGEN TANK SPRING BOLT CUP

a.

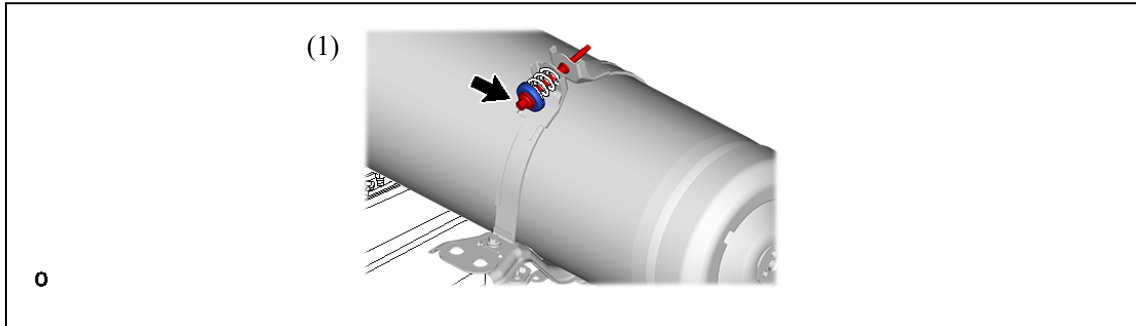

(1) Remove the bolt, front hydrogen tank spring bolt cup and compression spring

7. REMOVE NO. 1 HYDROGEN TANK BAND SUB-ASSEMBLY RH

a.

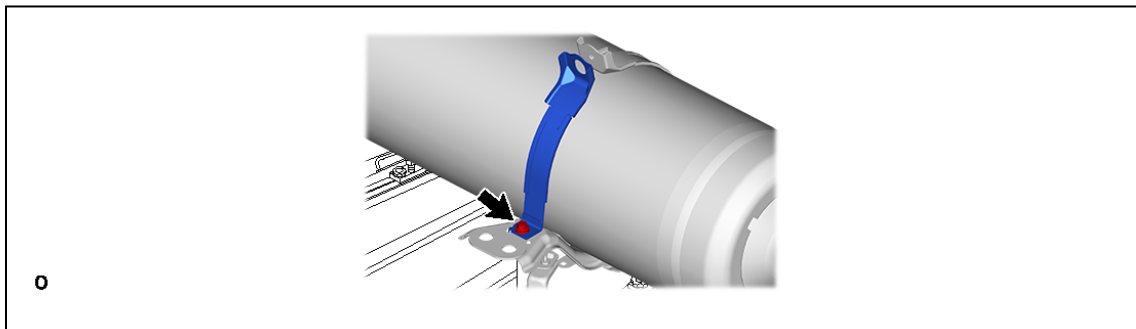

8. REMOVE NO. 1 HYDROGEN TANK BAND SUB-ASSEMBLY LH

a.

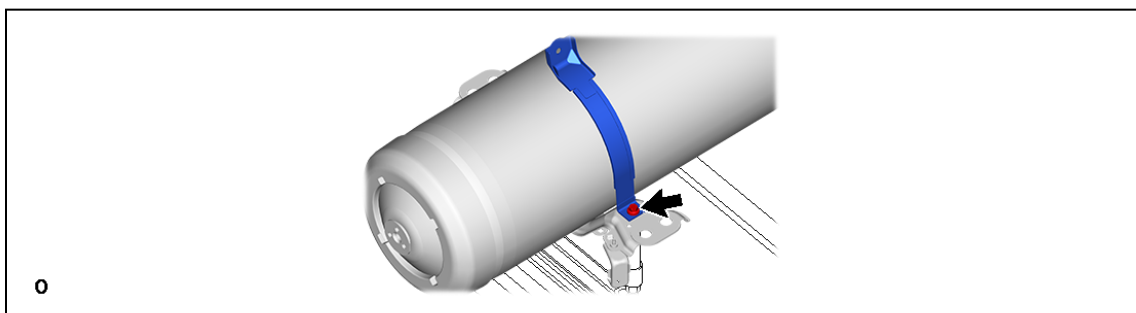

9. REMOVE UPPER HYDROGEN TANK BRACKET SUB-ASSEMBLY

a.

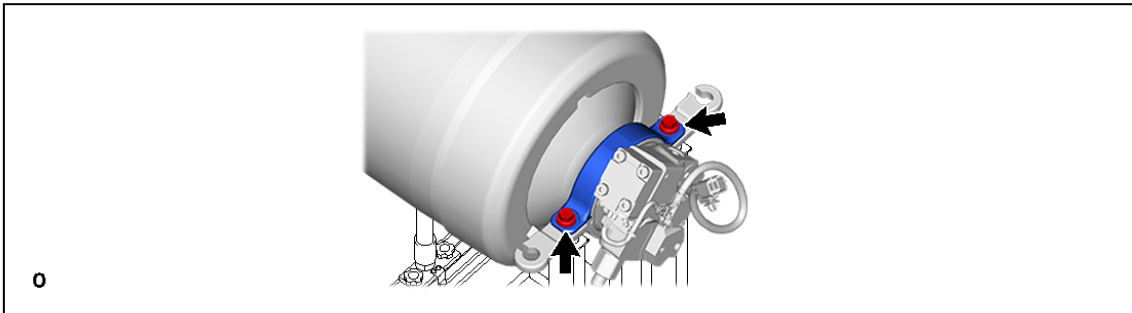

10. REMOVE NO. 1 HYDROGEN TANK ASSEMBLY

a.

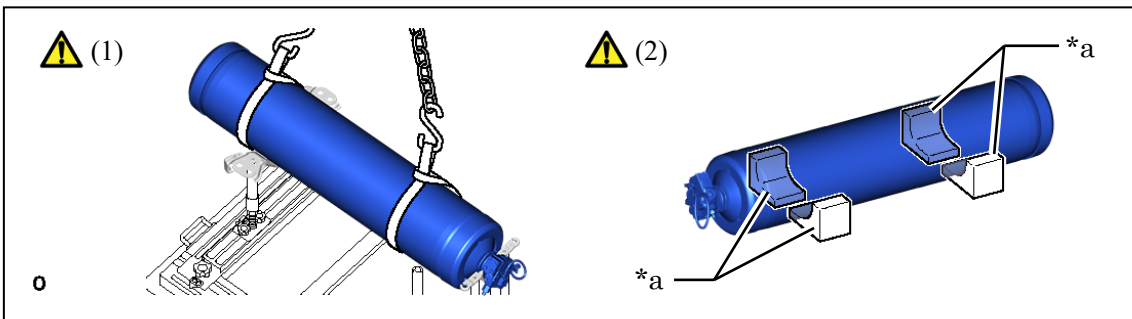

*a	Wheel Chocks	-	-
----	--------------	---	---

- (1) Using an engine sling device and belts, remove the No. 1 hydrogen tank assembly from the No. 1 hydrogen tank frame sub-assembly.

Caution:

- When hoisting up the hydrogen tank assembly, do not hoist it when not properly balanced.
- The hydrogen tank assembly could fall, resulting in a serious accident.

- (2) Place the No. 1 hydrogen tank assembly on wheel chocks or similar.

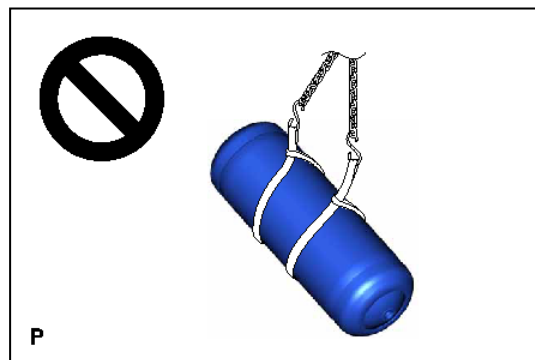

11. REMOVE REAR FLOOR SIDE MEMBER COVER RH

a.

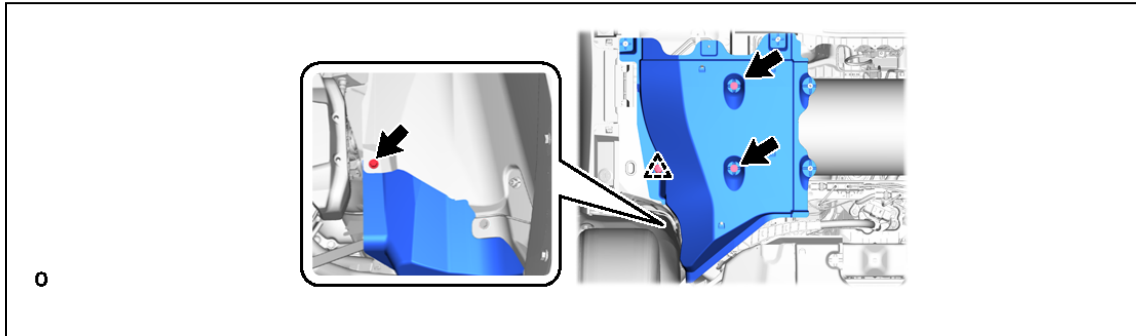

12. REMOVE NO. 1 DIFFERENTIAL SUPPORT PROTECTOR

a.

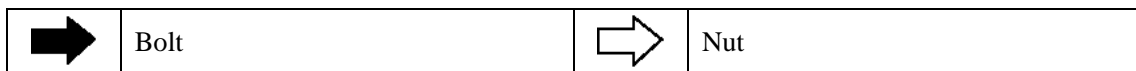
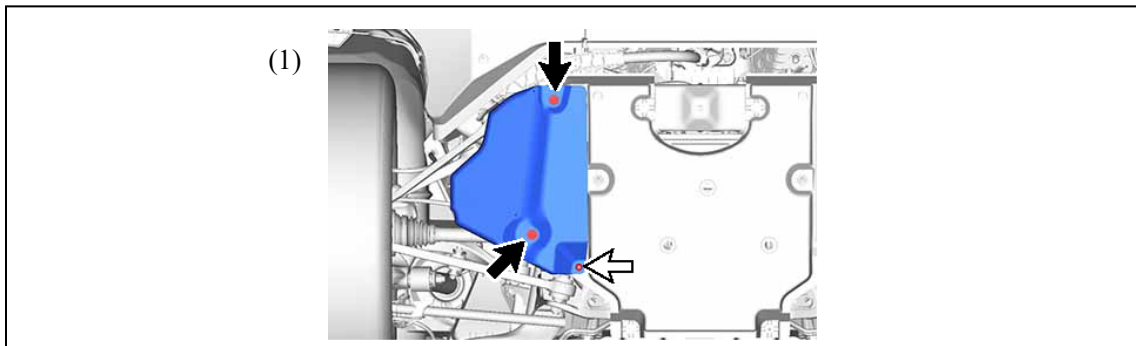

(1) Remove the 2 bolts, nut and No. 1 differential support protector.

13. REMOVE NO. 2 DIFFERENTIAL SUPPORT PROTECTOR

a.

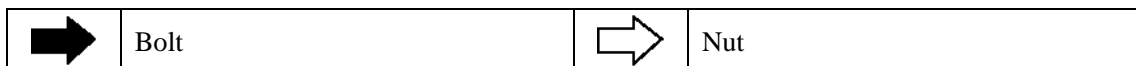
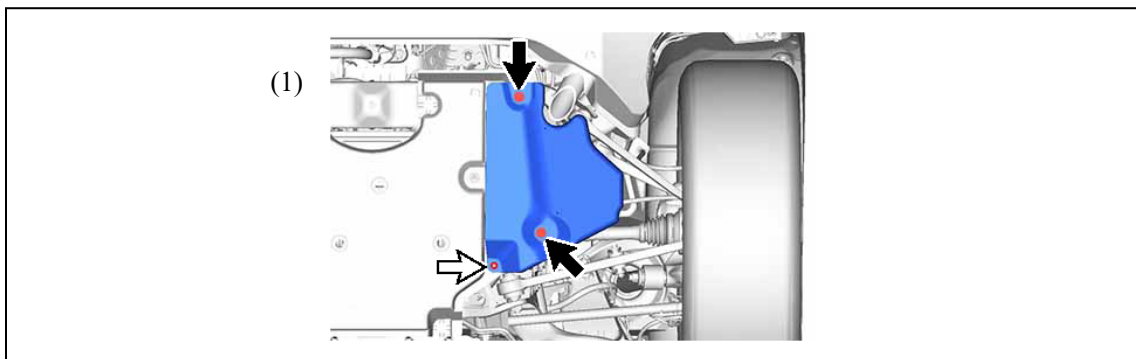

(1) Remove the 2 bolts, nut and No. 2 differential support protector.

14. REMOVE REAR SUSPENSION BRACE COVER

a.

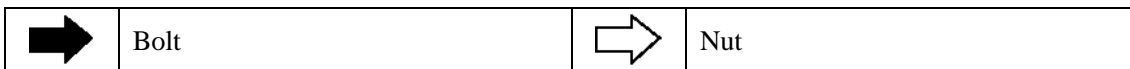
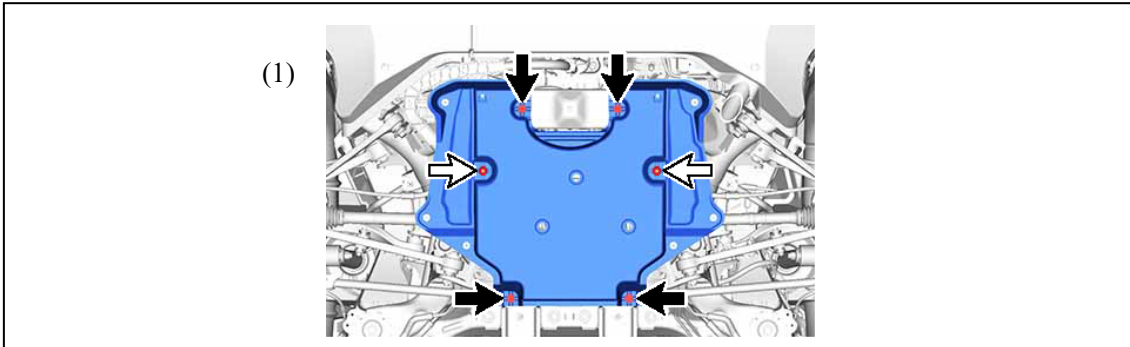

(1) Remove the 4 bolts and 2 nuts from the rear suspension brace cover.

15. DISCONNECT NO. 8 HYDROGEN TANK TUBE

	CAUTION:
	<ul style="list-style-type: none">• After performing depressurization procedures, when first loosening the union nut of the high pressure hydrogen piping, do not loosen the union nut by hand without wearing protective glasses and gloves.• Even when depressurization procedures are performed, the pressurized hydrogen gas inside the high pressure hydrogen piping cannot be completely depressurized, so the highly pressurized hydrogen gas remaining in the high pressure hydrogen piping could blow out, resulting in a serious accident.

a.

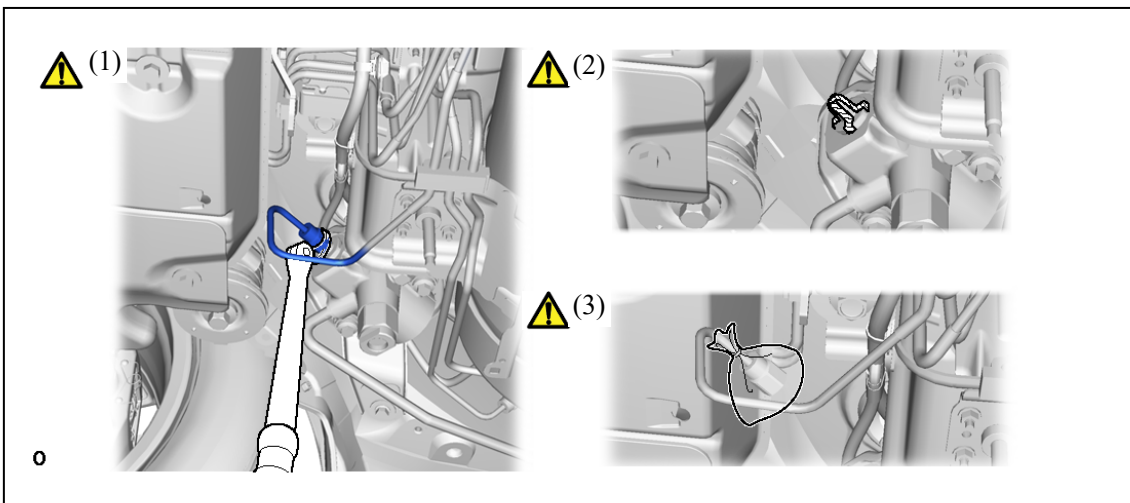

- (1) Using a 19 mm union nut wrench, loosen the union nut and disconnect the No. 8 hydrogen tank tube from the hydrogen supply regulator.
- (2) To prevent contamination by foreign matter, cover the openings of the hydrogen supply regulator with protective tape.
- (3) To prevent contamination by foreign matter, cover the connecting portions of the No. 8 hydrogen tank tube with plastic bags.

16. DISCONNECT NO. 3 HYDROGEN SUPPLY TUBE SUB-ASSEMBLY

a.

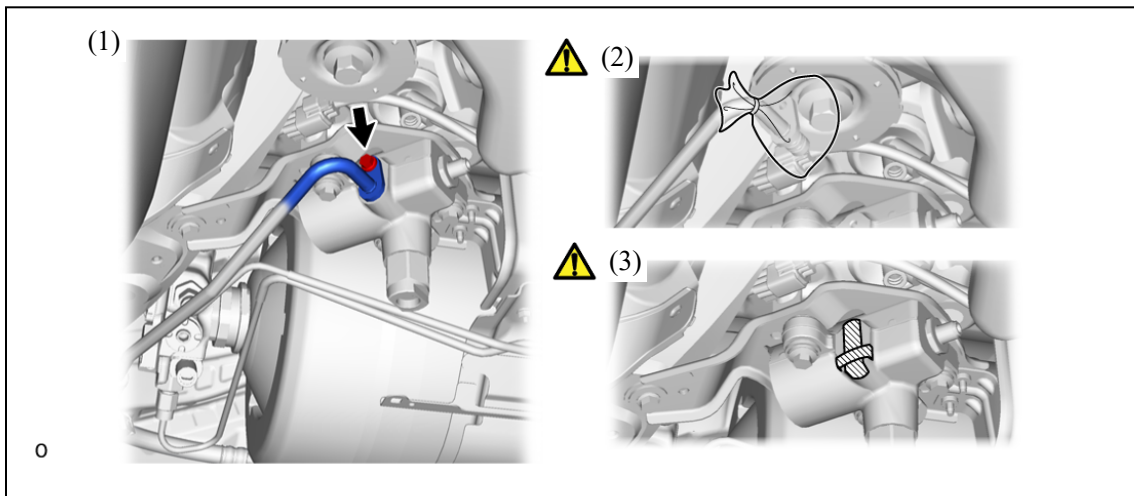

- (1) Remove the bolt and disconnect the No. 3 hydrogen supply tube sub-assembly from the hydrogen supply regulator.
- (2) To prevent contamination by foreign matter, cover the connecting portions of the No. 3 hydrogen supply tube sub-assembly with plastic bags.
- (3) To prevent contamination by foreign matter, cover the openings of the hydrogen supply regulator with protective tape.

17. REMOVE HYDROGEN SUPPLY REGULATOR



NOTICE:

Do not damage or deform the No. 8 hydrogen tank tube or No. 3 hydrogen supply tube sub-assembly.

a.

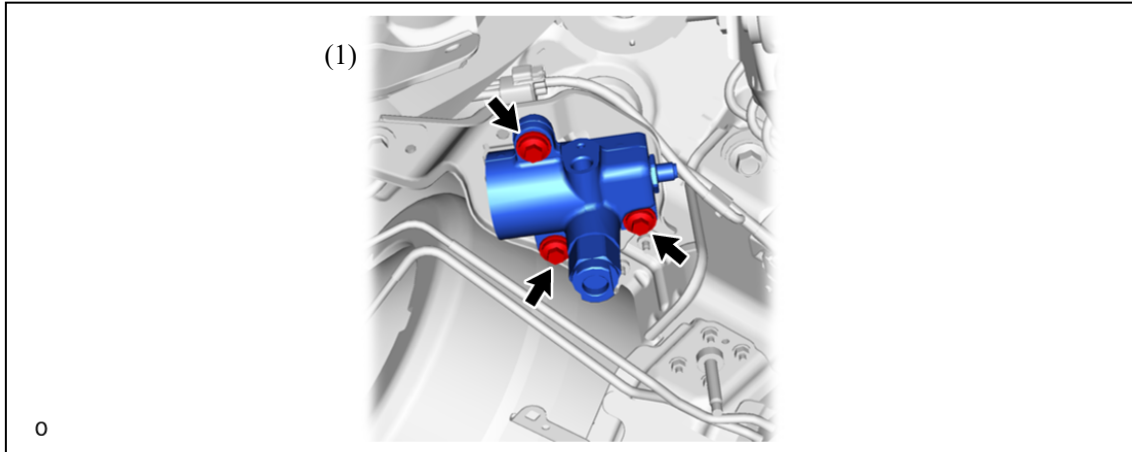

(1) Remove the 3 bolts and hydrogen supply regulator.

18. DISCONNECT FLOOR WIRE

a.

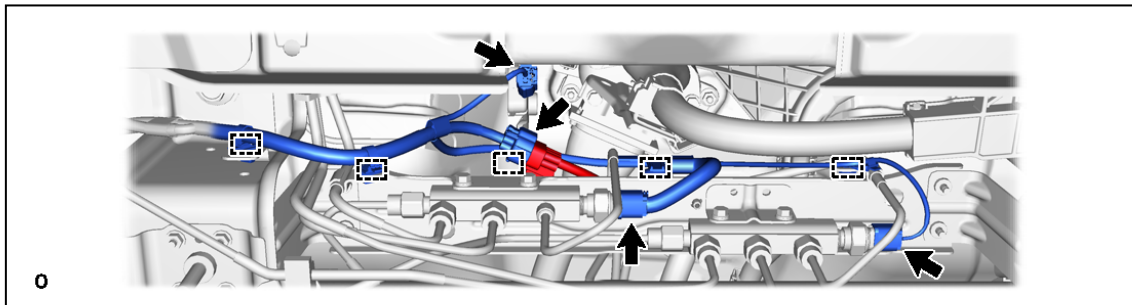

19. DISCONNECT NO. 2 HYDROGEN TANK TUBE

	<p>CAUTION:</p> <ul style="list-style-type: none">• After performing depressurization procedures, when first loosening the union nut of the high pressure hydrogen piping, do not loosen the union nut by hand without wearing protective glasses and gloves.• Even when depressurization procedures are performed, the pressurized hydrogen gas inside the high pressure hydrogen piping cannot be completely depressurized, so the highly pressurized hydrogen gas remaining in the high pressure hydrogen piping could blow out, resulting in a serious accident.
---	--

a.

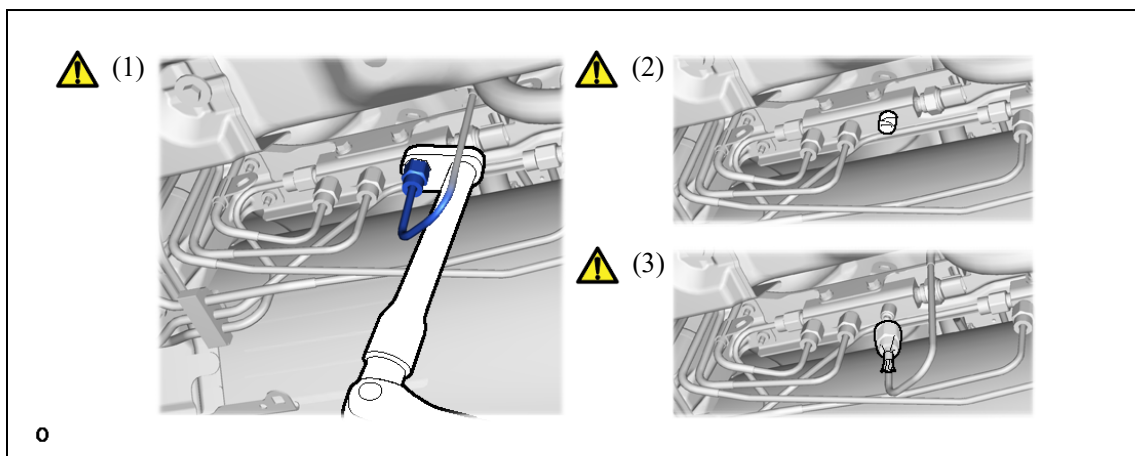

- (1) Using a 19 mm union nut wrench, loosen the union nut and disconnect the No. 2 hydrogen tank tube from the hydrogen tank tube joint assembly.
- (2) To prevent contamination by foreign matter, cover the openings of the hydrogen tank tube joint assembly with protective tape.
- (3) To prevent contamination by foreign matter, cover the connecting portions of the No. 2 hydrogen tank tube with plastic bags.

20. DISCONNECT NO. 4 HYDROGEN TANK TUBE (for 3 Hydrogen Tank)

	<p>CAUTION:</p> <ul style="list-style-type: none">• After performing depressurization procedures, when first loosening the union nut of the high pressure hydrogen piping, do not loosen the union nut by hand without wearing protective glasses and gloves.• Even when depressurization procedures are performed, the pressurized hydrogen gas inside the high pressure hydrogen piping cannot be completely depressurized, so the highly pressurized hydrogen gas remaining in the high pressure hydrogen piping could blow out, resulting in a serious accident.
---	--

a.

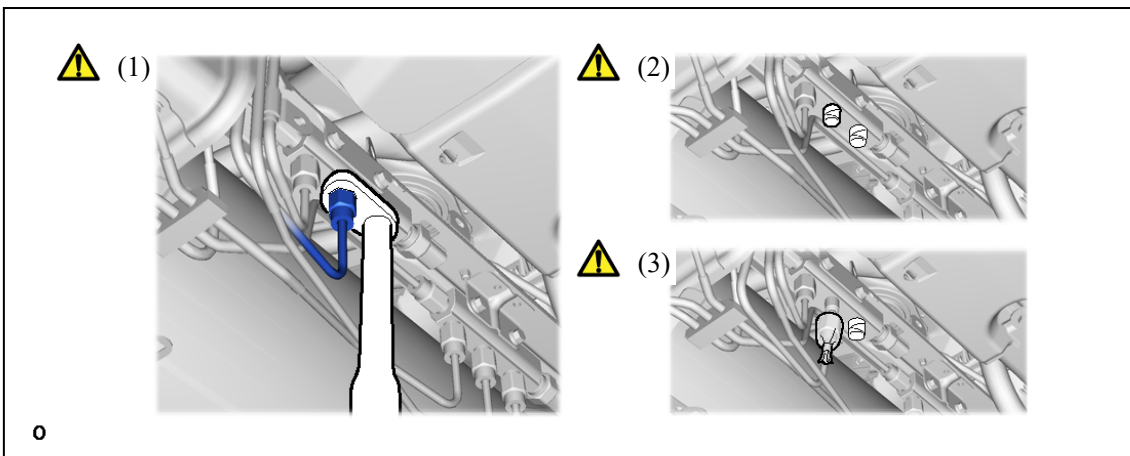

- (1) Using a 19 mm union nut wrench, loosen the union nut and disconnect the No. 4 hydrogen tank tube from the hydrogen tank tube joint assembly.
- (2) To prevent contamination by foreign matter, cover the openings of the hydrogen tank tube joint assembly with protective tape.
- (3) To prevent contamination by foreign matter, cover the connecting portions of the No. 4 hydrogen tank tube with plastic bags.

21. DISCONNECT NO. 1 HYDROGEN TANK TUBE

	<p>CAUTION:</p> <ul style="list-style-type: none">• After performing depressurization procedures, when first loosening the union nut of the high pressure hydrogen piping, do not loosen the union nut by hand without wearing protective glasses and gloves.• Even when depressurization procedures are performed, the pressurized hydrogen gas inside the high pressure hydrogen piping cannot be completely depressurized, so the highly pressurized hydrogen gas remaining in the high pressure hydrogen piping could blow out, resulting in a serious accident.
---	--

a.

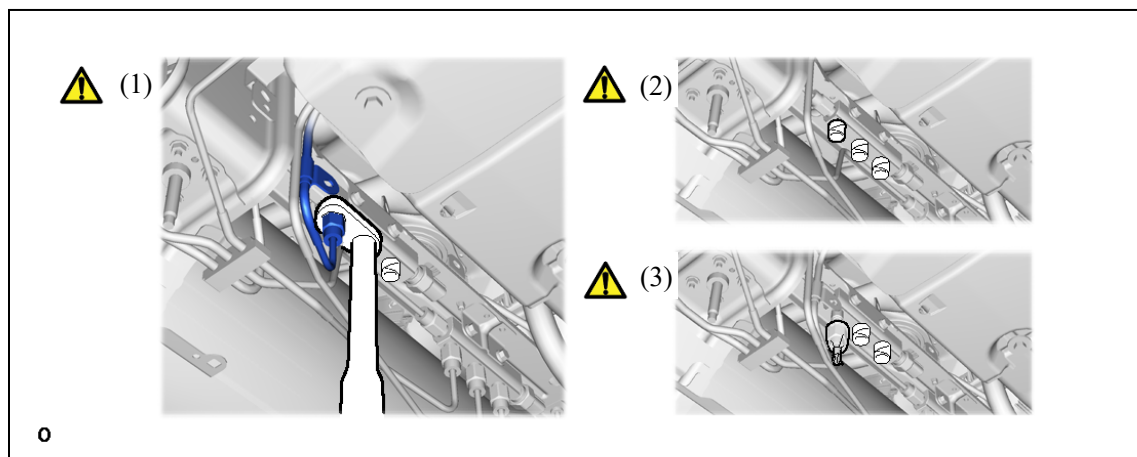

- (1) Using a 19 mm union nut wrench, loosen the union nut and disconnect the No. 1 hydrogen tank tube from the hydrogen tank tube joint assembly.
- (2) To prevent contamination by foreign matter, cover the openings of the hydrogen tank tube joint assembly with protective tape.
- (3) To prevent contamination by foreign matter, cover the connecting portions of the No. 1 hydrogen tank tube with plastic bags.

22. DISCONNECT NO. 3 HYDROGEN TANK TUBE

	<p>CAUTION:</p> <ul style="list-style-type: none">• After performing depressurization procedures, when first loosening the union nut of the high pressure hydrogen piping, do not loosen the union nut by hand without wearing protective glasses and gloves.• Even when depressurization procedures are performed, the pressurized hydrogen gas inside the high pressure hydrogen piping cannot be completely depressurized, so the highly pressurized hydrogen gas remaining in the high pressure hydrogen piping could blow out, resulting in a serious accident.
---	--

a.

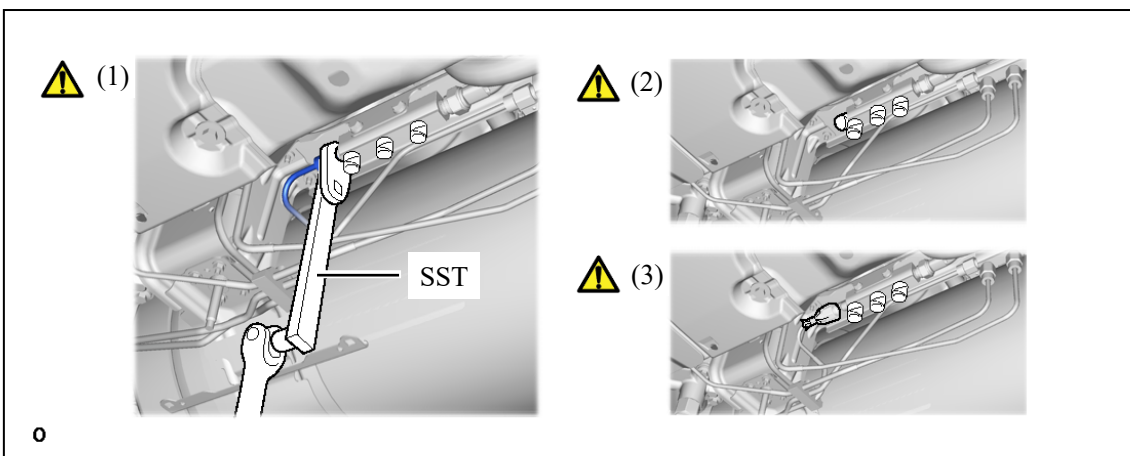

- (1) Using SST and a 19 mm union nut wrench, loosen the union nut and disconnect the No. 3 hydrogen tank tube from the hydrogen tank tube joint assembly.

SST

09961-01270

- (2) To prevent contamination by foreign matter, cover the openings of the hydrogen tank tube joint assembly with protective tape.
- (3) To prevent contamination by foreign matter, cover the connecting portions of the No. 3 hydrogen tank tube with plastic bags.

23. REMOVE HYDROGEN TANK TUBE JOINT ASSEMBLY

a.

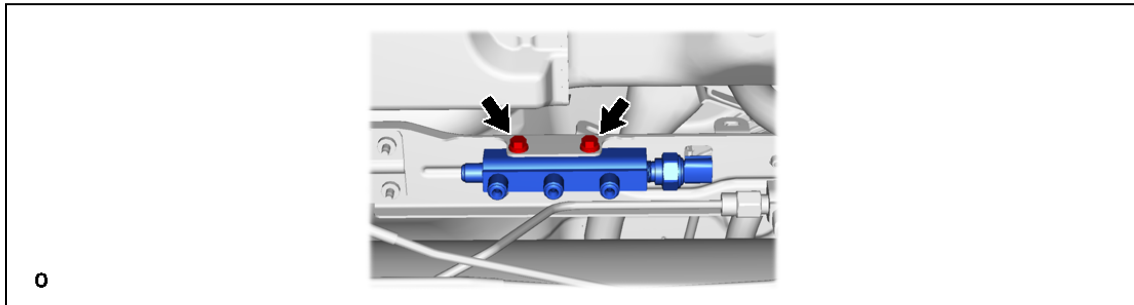

24. DISCONNECT NO. 5 HYDROGEN TANK TUBE

	CAUTION:
	<ul style="list-style-type: none">• After performing depressurization procedures, when first loosening the union nut of the high pressure hydrogen piping, do not loosen the union nut by hand without wearing protective glasses and gloves.• Even when depressurization procedures are performed, the pressurized hydrogen gas inside the high pressure hydrogen piping cannot be completely depressurized, so the highly pressurized hydrogen gas remaining in the high pressure hydrogen piping could blow out, resulting in a serious accident.

a.

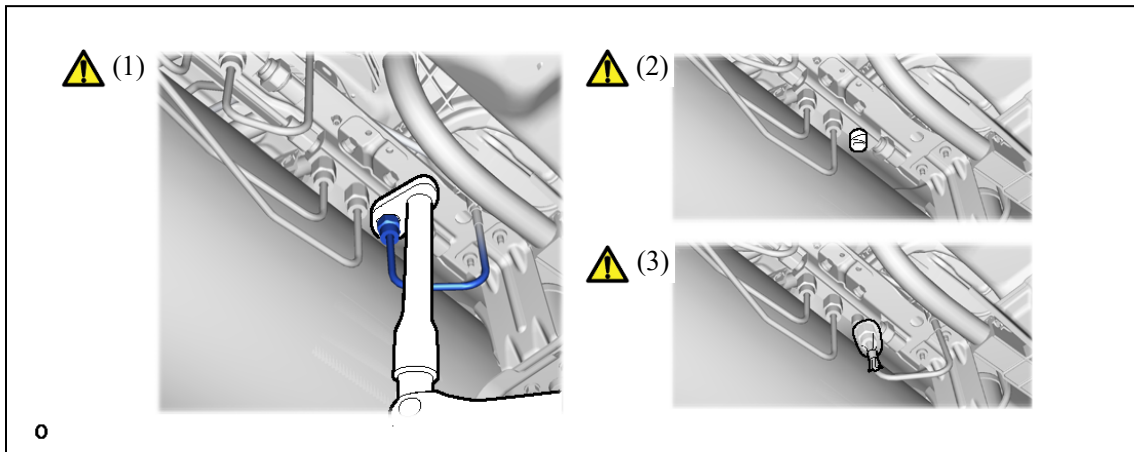

- (1) Using a 19 mm union nut wrench, loosen the union nut and disconnect the No. 5 hydrogen tank tube from the hydrogen tank tube joint assembly.
- (2) To prevent contamination by foreign matter, cover the openings of the hydrogen tank tube joint assembly with protective tape.
- (3) To prevent contamination by foreign matter, cover the connecting portions of the No. 5 hydrogen tank tube with plastic bags.

25. DISCONNECT NO. 7 HYDROGEN TANK TUBE (for 3 Hydrogen Tank)

	<p>CAUTION:</p> <ul style="list-style-type: none">• After performing depressurization procedures, when first loosening the union nut of the high pressure hydrogen piping, do not loosen the union nut by hand without wearing protective glasses and gloves.• Even when depressurization procedures are performed, the pressurized hydrogen gas inside the high pressure hydrogen piping cannot be completely depressurized, so the highly pressurized hydrogen gas remaining in the high pressure hydrogen piping could blow out, resulting in a serious accident.
---	--

a.

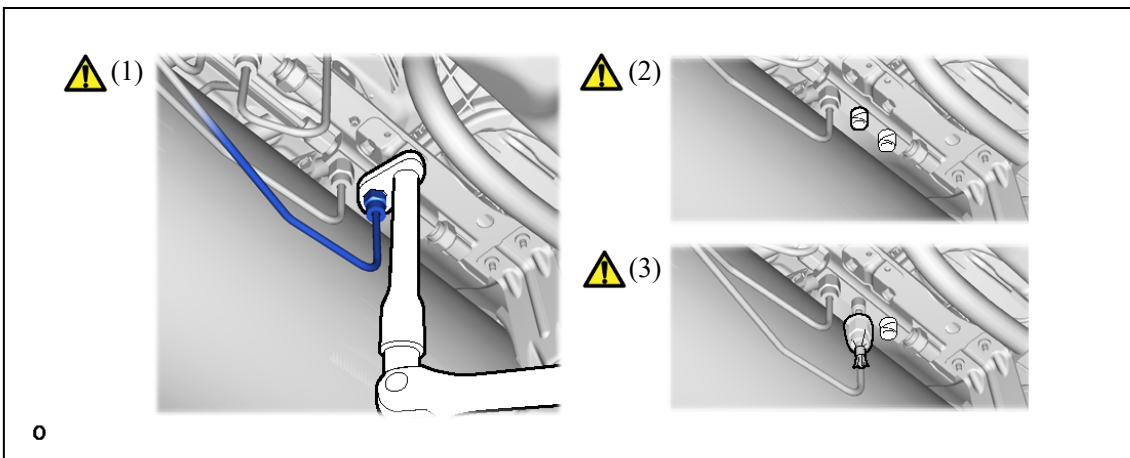

- (1) Using a 19 mm union nut wrench, loosen the union nut and disconnect the No. 7 hydrogen tank tube from the hydrogen tank tube joint assembly.
- (2) To prevent contamination by foreign matter, cover the openings of the hydrogen tank tube joint assembly with protective tape.
- (3) To prevent contamination by foreign matter, cover the connecting portions of the No. 7 hydrogen tank tube with plastic bags.

26. DISCONNECT NO. 8 HYDROGEN TANK TUBE

	<p>CAUTION:</p> <ul style="list-style-type: none">• After performing depressurization procedures, when first loosening the union nut of the high pressure hydrogen piping, do not loosen the union nut by hand without wearing protective glasses and gloves.• Even when depressurization procedures are performed, the pressurized hydrogen gas inside the high pressure hydrogen piping cannot be completely depressurized, so the highly pressurized hydrogen gas remaining in the high pressure hydrogen piping could blow out, resulting in a serious accident.
---	--

a.

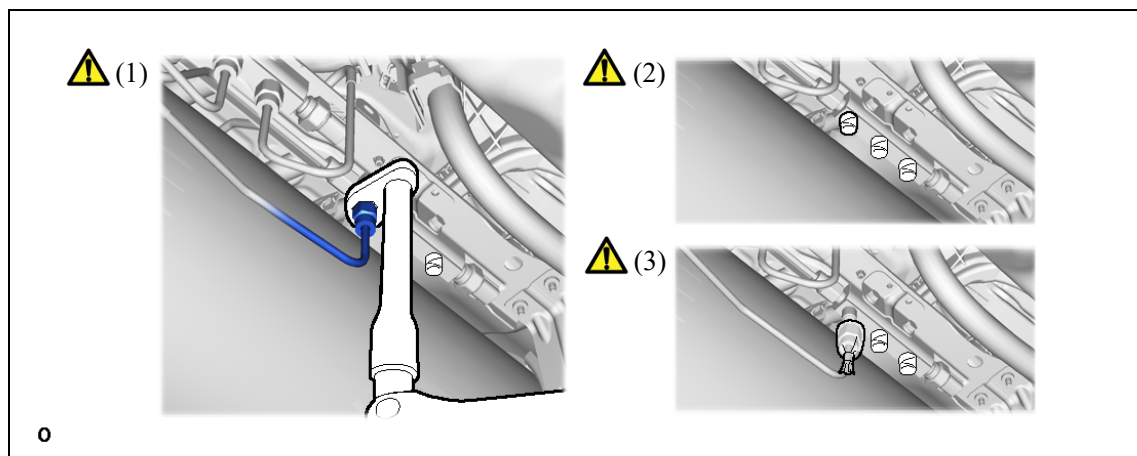

- (1) Using a 19 mm union nut wrench, loosen the union nut and disconnect the No. 8 hydrogen tank tube from the hydrogen tank tube joint assembly.
- (2) To prevent contamination by foreign matter, cover the openings of the hydrogen tank tube joint assembly with protective tape.
- (3) To prevent contamination by foreign matter, cover the connecting portions of the No. 8 hydrogen tank tube with plastic bags.

27. DISCONNECT NO. 6 HYDROGEN TANK TUBE

	<p>CAUTION:</p> <ul style="list-style-type: none">• After performing depressurization procedures, when first loosening the union nut of the high pressure hydrogen piping, do not loosen the union nut by hand without wearing protective glasses and gloves.• Even when depressurization procedures are performed, the pressurized hydrogen gas inside the high pressure hydrogen piping cannot be completely depressurized, so the highly pressurized hydrogen gas remaining in the high pressure hydrogen piping could blow out, resulting in a serious accident.
---	--

a.

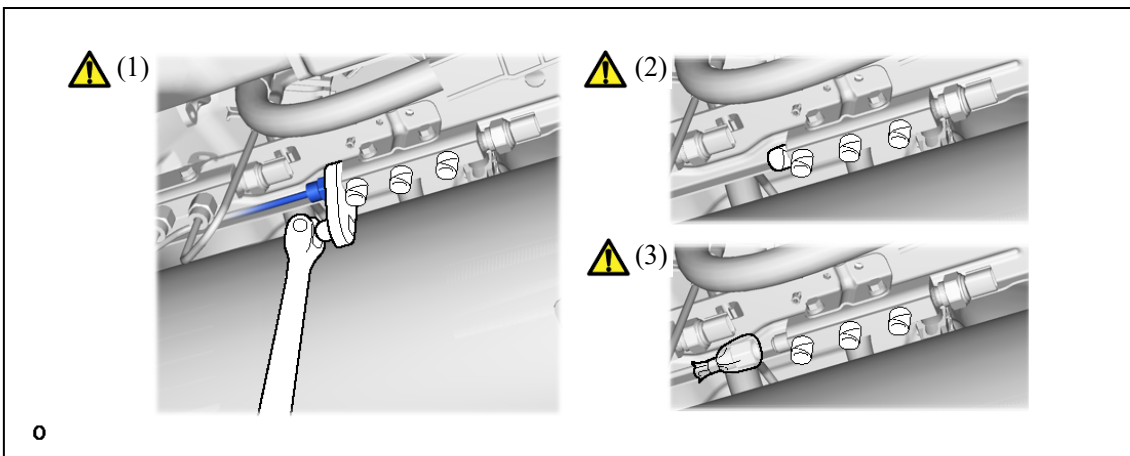

- (1) Using a 19 mm union nut wrench, loosen the union nut and disconnect the No. 6 hydrogen tank tube from the hydrogen tank tube joint assembly.
- (2) To prevent contamination by foreign matter, cover the openings of the hydrogen tank tube joint assembly with protective tape.
- (3) To prevent contamination by foreign matter, cover the connecting portions of the No. 6 hydrogen tank tube with plastic bags.

28. REMOVE HYDROGEN TANK TUBE JOINT ASSEMBLY

a.

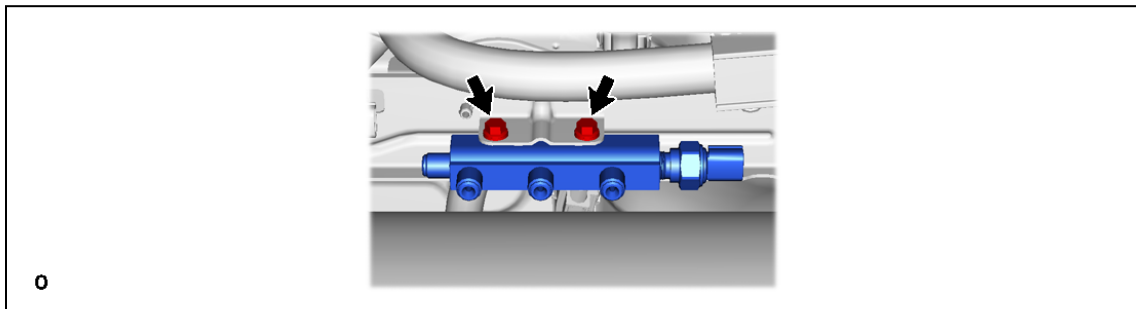

29. REMOVE MOTOR CABLE

a.

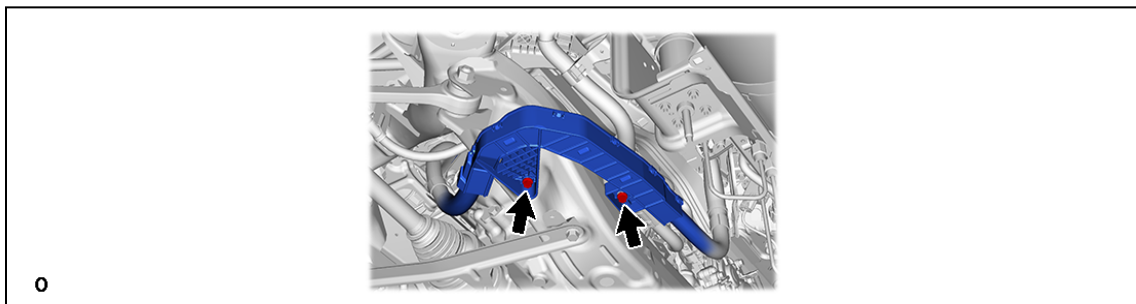

30. REMOVE NO. 3 FLOOR WIRE

a.

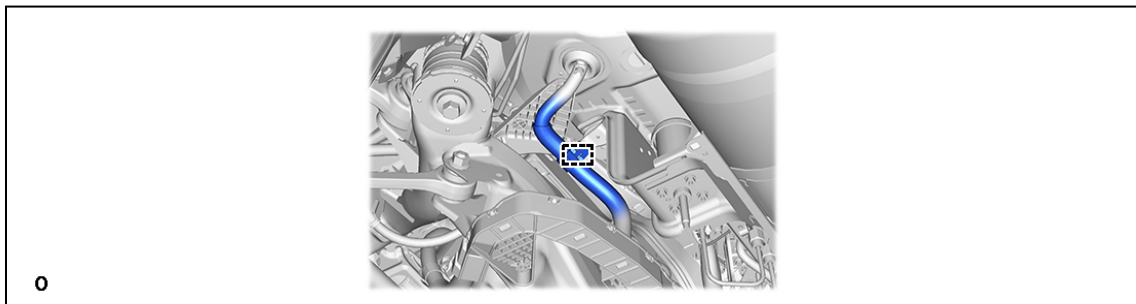

31. REMOVE NO. 3 FUEL TUBE CLAMP

a.

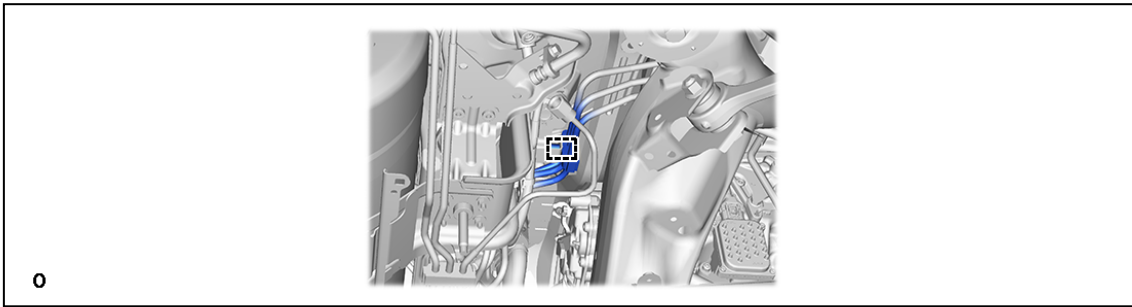

32. REMOVE NO. 5 FUEL TUBE CLAMP

a.

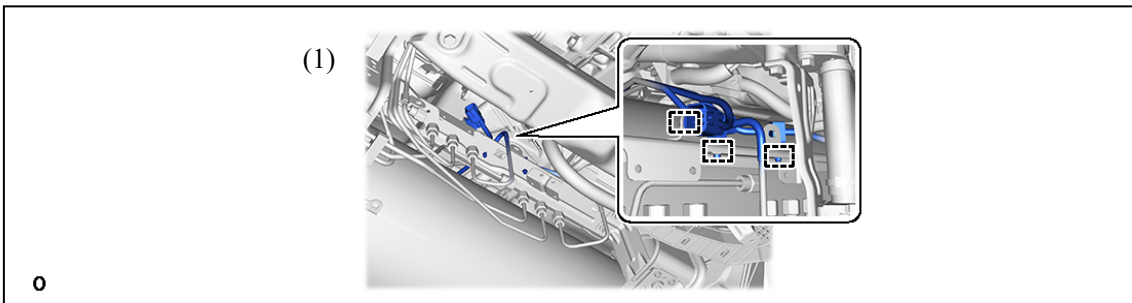

(1) Detach the 3 clamp and disconnect the connector and 2 No. 5 fuel tube clamps from the No. 1 hydrogen tank bracket.

33. REMOVE NO. 2 HYDROGEN TANK ASSEMBLY

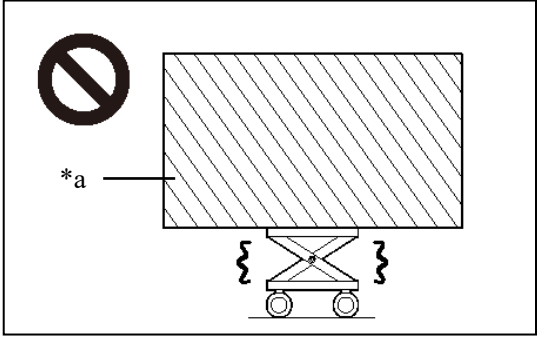
	CAUTION: <ul style="list-style-type: none">• Because the hydrogen tank assembly is extremely heavy, make sure to follow the work procedures described in the repair manual.• If work is not performed according to the procedures described in the repair manual, there is a danger that the engine lifter could drop and components could fall down.		
		<table border="1"><tr><td style="text-align: center; vertical-align: middle;">*a</td><td>Heavy load exceeding the weight limits or size limits of the engine lifter</td></tr></table>	*a
*a	Heavy load exceeding the weight limits or size limits of the engine lifter		

a.

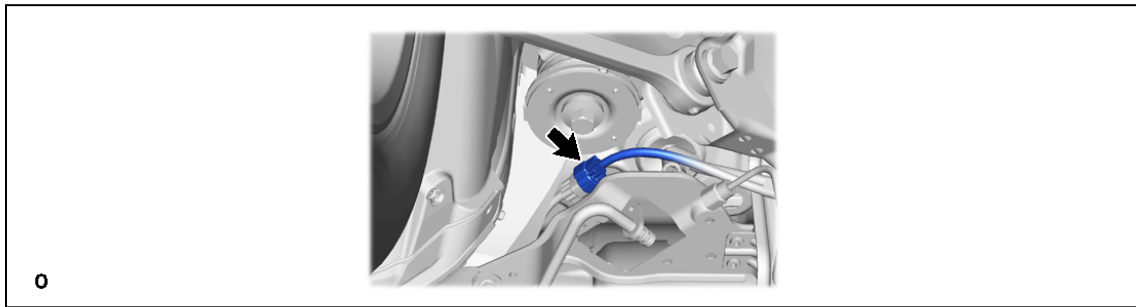

b.

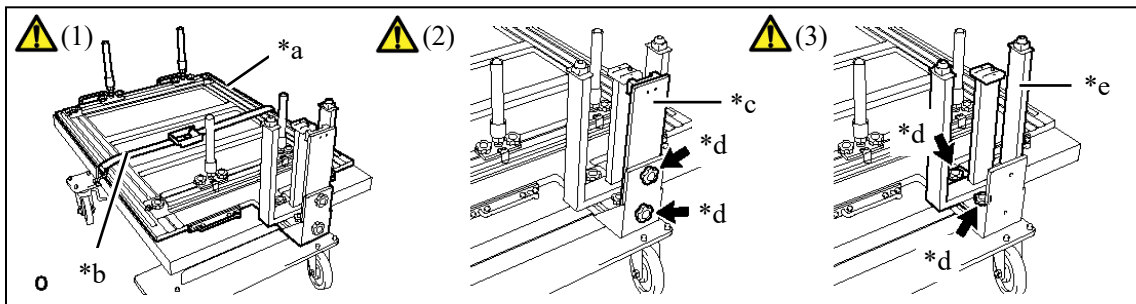

*a	SST (Hydrogen Tank Stand No. 2)	*b	Belt
*c	SST (Support No. 1)	*d	SST (Set Bolt A)
*e	SST (Support No. 2)	-	-

(1) Set SST (hydrogen tank stand No. 2) on the engine lifter and secure it with the belt.

SST

09403-62030

Notice:

Set SST (hydrogen tank stand No. 2) in the middle of the engine lifter and secure the center portion with the belt.

(2) Remove 2 SST (set bolt A) and SST (support No. 1).

SST

09403-62030 (09403-06200, 09403-06210)

(3) Remove 2 SST (set bolt A) and SST (support No. 2).

SST

09403-62030 (09403-06210, 09403-06220)

c.

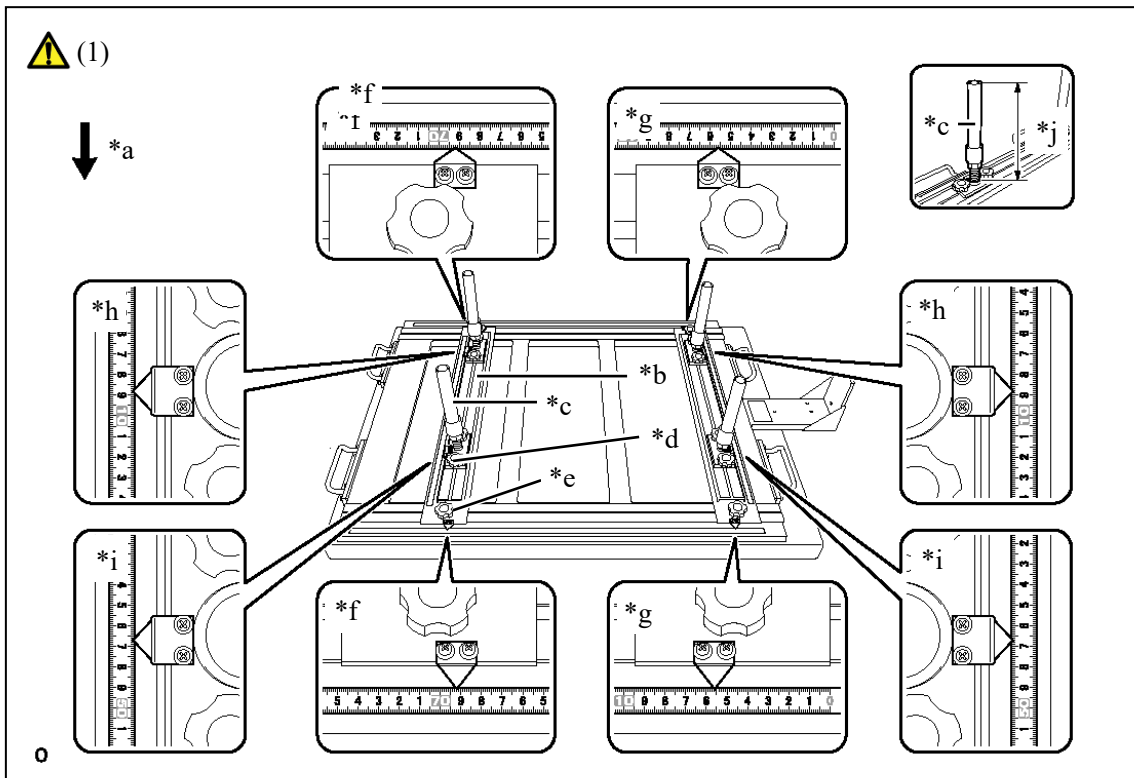

*a	Front side of vehicle	*b	SST (Support Rail No. 1)
*c	SST (Support No. 3)	*d	SST (Set Bolt C)
*e	SST (Set Bolt B)	*f	Scale surface: 692 mm (27.2 in.)
*g	Scale surface: 56 mm (2.20 in.)	*h	Scale surface: 88 mm (3.47 in.)
*i	Scale surface: 467 mm (18.4 in.)	*j	Front side of vehicle: 244 mm (9.61 in.) Rear side of vehicle: 265 mm (10.4 in.)

(1) Adjust SST (support No. 3), SST (support rail No. 1), and tighten SST (set bolt B), SST (set bolt C).

SST

09403-62030 (09403-06230, 09403-06240, 09403-06250, 09403-06260)

Hint:

This is done to align SST (hydrogen tank stand No. 2) with the installation condition of the No. 2 hydrogen tank assembly on the vehicle.

e.

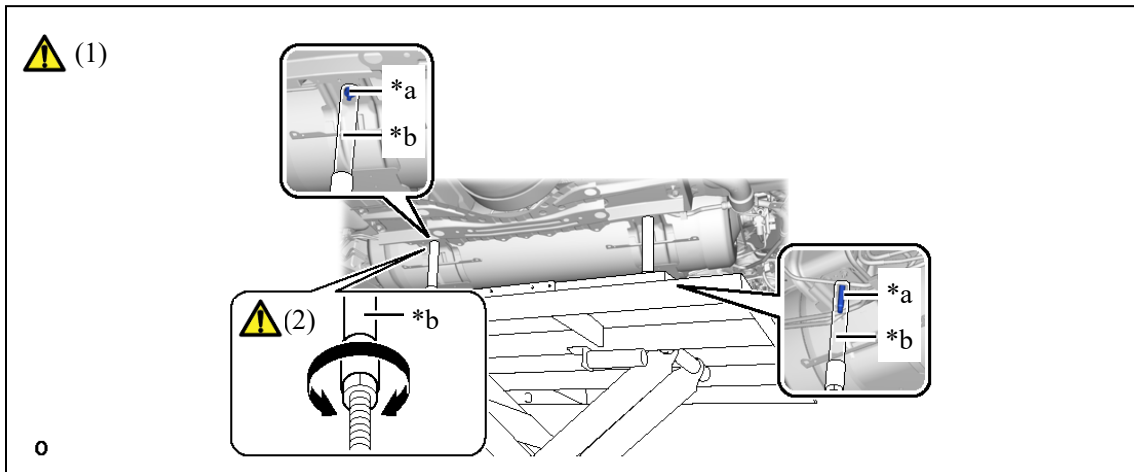

*a	Protrusion	*b	SST (Support No. 3)
----	------------	----	---------------------

- (1) Operate the engine lifter, and set SST (hydrogen tank stand No. 2) against the No. 2 hydrogen tank assembly.

Notice:

Align the protrusions of each No. 2 hydrogen tank frame sub-assembly with the holes of SST (support No. 3).

- (2) When the gap between the No. 2 hydrogen tank frame sub-assembly and SST (support No. 3) is large, rotate SST (support No. 3) to adjust the height.

f.

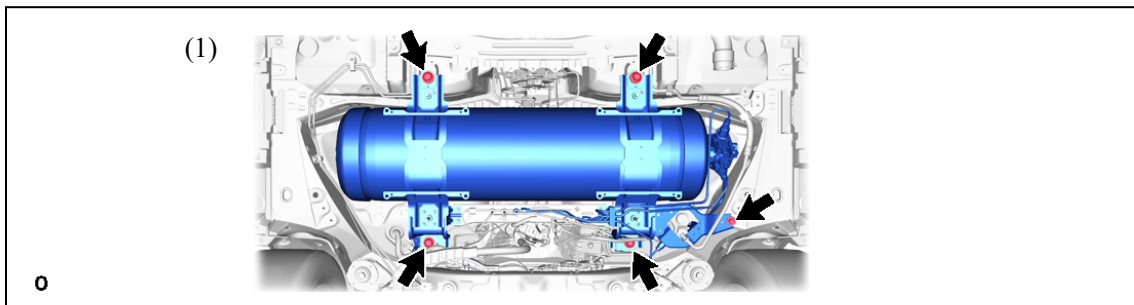

- (1) Remove the 5 bolts.
- (2) Operate the engine lifter and slowly remove the No. 2 hydrogen tank assembly from the vehicle.

Notice:

Make sure that the No. 2 hydrogen tank assembly does not interfere with the hydrogen tank tube.

34. REMOVE HYDROGEN DETECTOR

a.

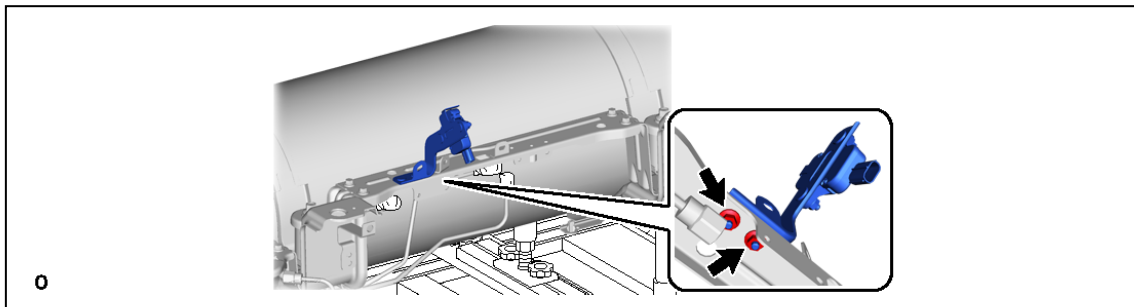

35. REMOVE NO. 8 HYDROGEN TANK TUBE

a.

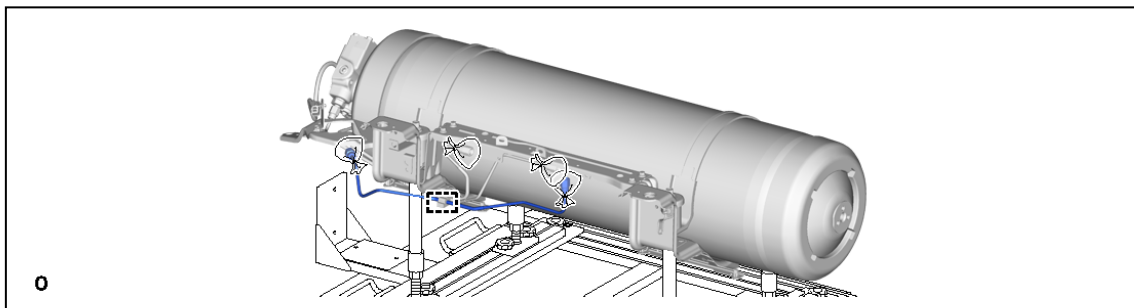

36. REMOVE NO. 6 HYDROGEN TANK TUBE



CAUTION:

- **After performing depressurization procedures, when first loosening the union nut of the high pressure hydrogen piping, do not loosen the union nut by hand without wearing protective glasses and gloves.**
- **Even when depressurization procedures are performed, the pressurized hydrogen gas inside the high pressure hydrogen piping cannot be completely depressurized, so the highly pressurized hydrogen gas remaining in the high pressure hydrogen piping could blow out, resulting in a serious accident.**

b.

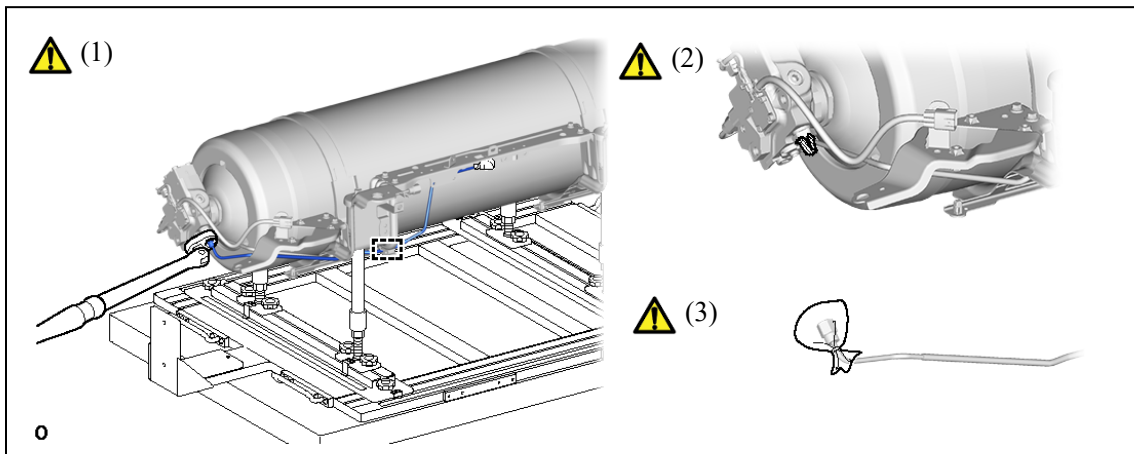

- (1) Detach the clamp and using a 19 mm union nut wrench, loosen the union nut and remove the No. 6 hydrogen tank tube from the No. 2 hydrogen tank assembly.
- (2) To prevent contamination by foreign matter, cover the openings of the No. 2 hydrogen tank assembly with protective tape.
- (3) To prevent contamination by foreign matter, cover the connecting portions of the No. 6 hydrogen tank tube with plastic bags.

37. REMOVE NO. 3 HYDROGEN TANK TUBE

	<p>CAUTION:</p> <ul style="list-style-type: none">• After performing depressurization procedures, when first loosening the union nut of the high pressure hydrogen piping, do not loosen the union nut by hand without wearing protective glasses and gloves.• Even when depressurization procedures are performed, the pressurized hydrogen gas inside the high pressure hydrogen piping cannot be completely depressurized, so the highly pressurized hydrogen gas remaining in the high pressure hydrogen piping could blow out, resulting in a serious accident.
--	--

a.

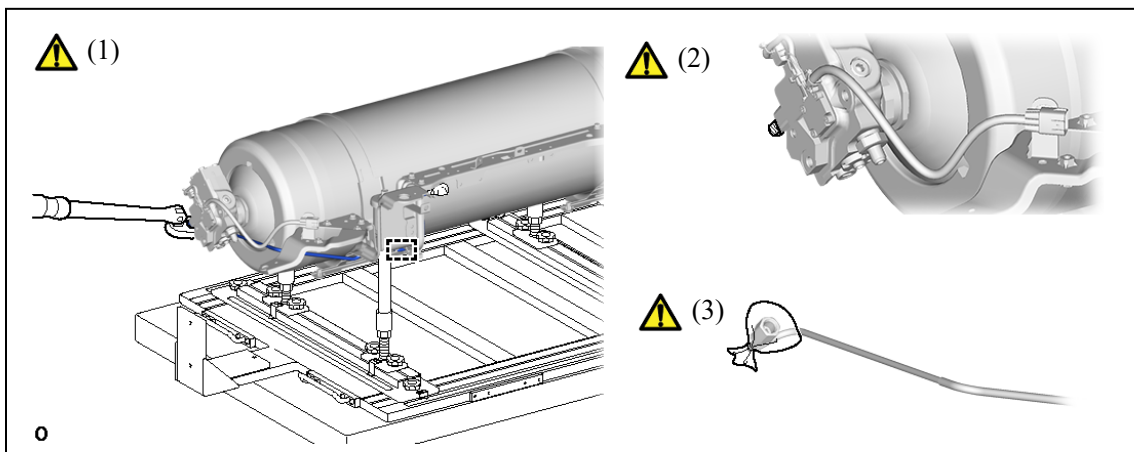

- (1) Detach the clamp and using a 19 mm union nut wrench, loosen the union nut and remove the No. 3 hydrogen tank tube from the No. 2 hydrogen tank assembly.
- (2) To prevent contamination by foreign matter, cover the openings of the No. 2 hydrogen tank assembly with protective tape.
- (3) To prevent contamination by foreign matter, cover the connecting portions of the No. 3 hydrogen tank tube with plastic bags.

38. REMOVE NO. 4 FUEL TUBE CLAMP

a.

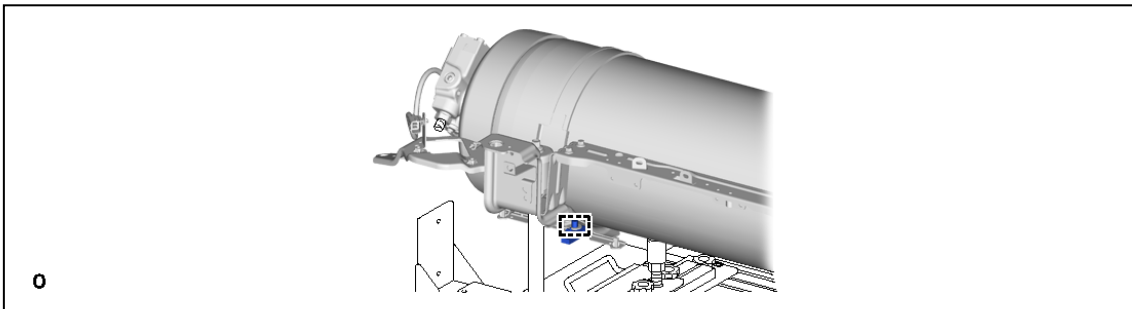

39. REMOVE NO. 2 HYDROGEN TANK BRACKET

a.

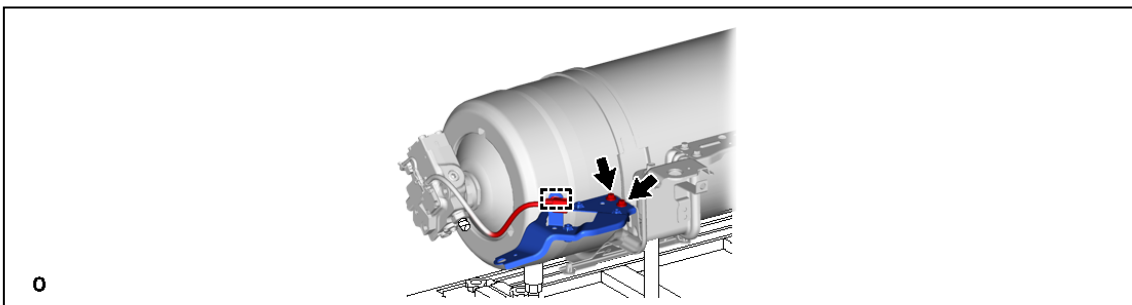

40. REMOVE NO. 1 HYDROGEN TANK BRACKET

a.

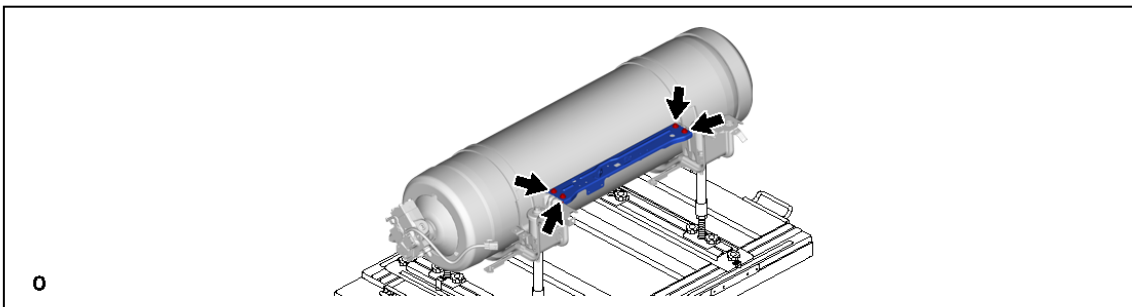

41. REMOVE NO. 2 HYDROGEN TANK SPRING BOLT CUP

a.

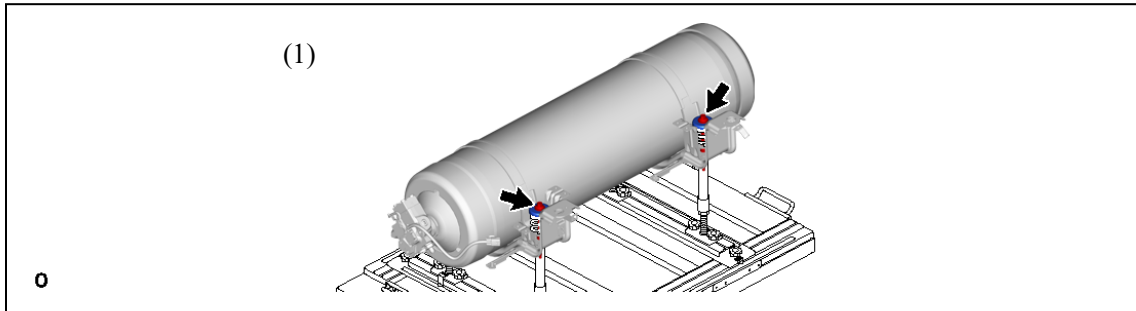

(1) Remove the 2 bolts, 2 No. 2 hydrogen tank spring bolt cups and 2 compression springs.

42. REMOVE NO. 2 HYDROGEN TANK BAND SUB-ASSEMBLY

a.

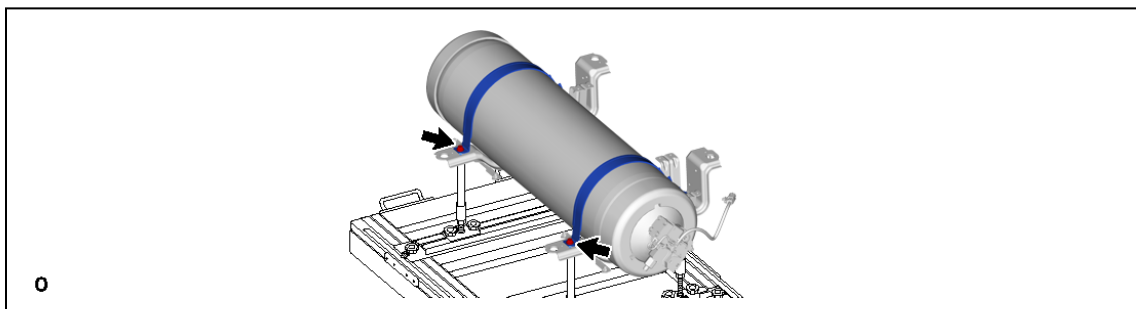

43. REMOVE NO. 2 HYDROGEN TANK ASSEMBLY

a.

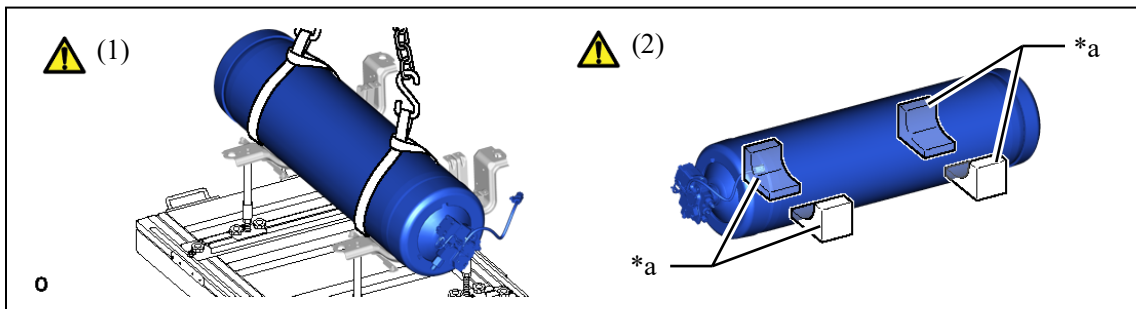

*a	Wheel Chocks	-	-
----	--------------	---	---

(1) Using an engine sling device and belts, remove the No. 2 hydrogen tank assembly from the No. 2 hydrogen tank frame sub-assembly.

Caution:

- When hoisting up the hydrogen tank assembly, do not hoist it when not properly balanced.
- The hydrogen tank assembly could fall, resulting in a serious accident.

- (2) Place the No. 2 hydrogen tank assembly on wheel chocks or similar.

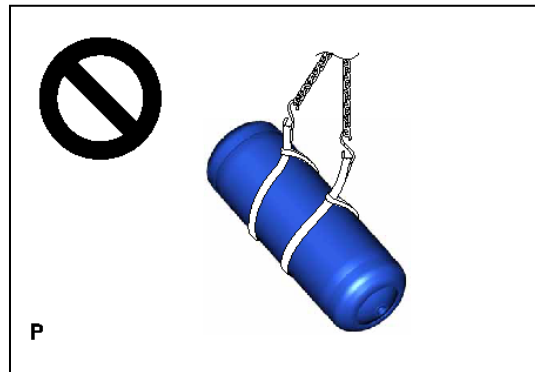

44. DISCONNECT NO. 4 HYDROGEN TANK TUBE (for 3 Hydrogen Tank)



CAUTION:

- After performing depressurization procedures, when first loosening the union nut of the high pressure hydrogen piping, do not loosen the union nut by hand without wearing protective glasses and gloves.
- Even when depressurization procedures are performed, the pressurized hydrogen gas inside the high pressure hydrogen piping cannot be completely depressurized, so the highly pressurized hydrogen gas remaining in the high pressure hydrogen piping could blow out, resulting in a serious accident.

a.

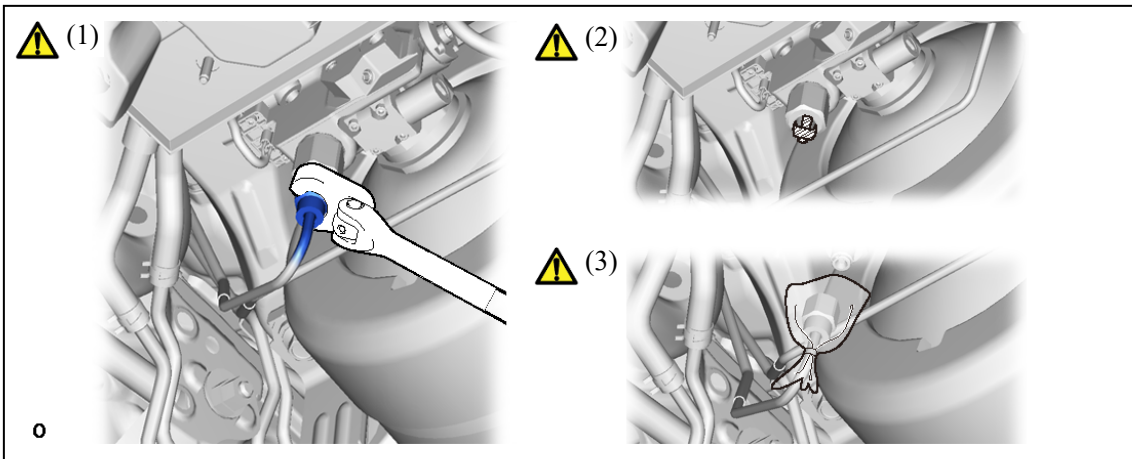

- (1) Using a 19 mm union nut wrench, loosen the union nut and disconnect the No. 4 hydrogen tank tube from the No. 3 hydrogen tank assembly.
- (2) To prevent contamination by foreign matter, cover the openings of the No. 3 hydrogen tank assembly with protective tape.
- (3) To prevent contamination by foreign matter, cover the connecting portions of the No. 4 hydrogen tank tube with plastic bags.

45. DISCONNECT NO. 7 HYDROGEN TANK TUBE (for 3 Hydrogen Tank)

	<p>CAUTION:</p> <ul style="list-style-type: none">• After performing depressurization procedures, when first loosening the union nut of the high pressure hydrogen piping, do not loosen the union nut by hand without wearing protective glasses and gloves.• Even when depressurization procedures are performed, the pressurized hydrogen gas inside the high pressure hydrogen piping cannot be completely depressurized, so the highly pressurized hydrogen gas remaining in the high pressure hydrogen piping could blow out, resulting in a serious accident.
---	--

a.

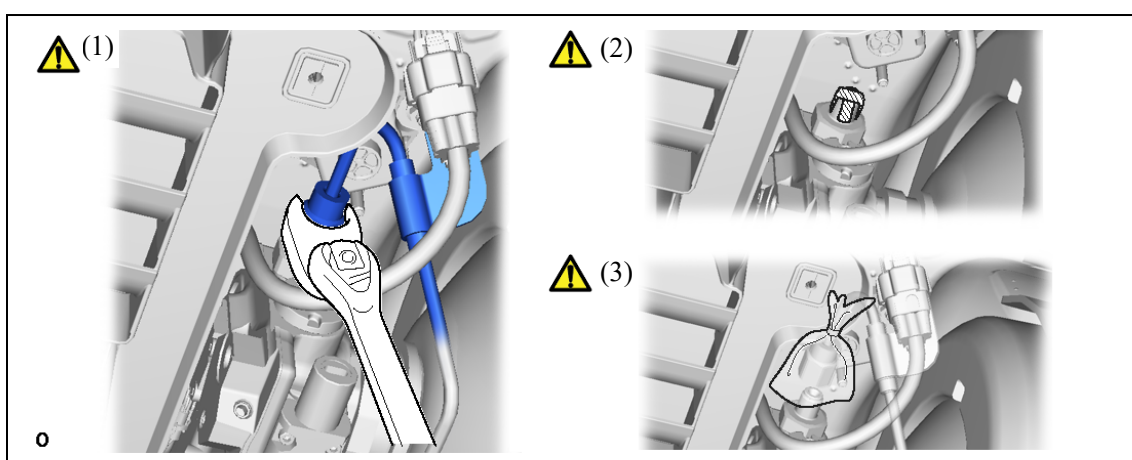

- (1) Using a 19 mm union nut wrench, loosen the union nut and disconnect the No. 7 hydrogen tank tube from the No. 3 hydrogen tank assembly.
- (2) To prevent contamination by foreign matter, cover the openings of the No. 3 hydrogen tank assembly with protective tape.
- (3) To prevent contamination by foreign matter, cover the connecting portions of the No. 7 hydrogen tank tube with plastic bags.

46. REMOVE NO. 3 HYDROGEN TANK ASSEMBLY (for 3 Hydrogen Tank)

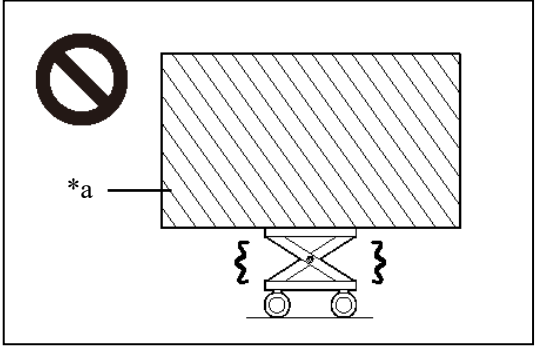
	<p>CAUTION:</p> <ul style="list-style-type: none"> Because the hydrogen tank assembly is extremely heavy, make sure to follow the work procedures described in the repair manual. If work is not performed according to the procedures described in the repair manual, there is a danger that the engine lifter could drop and components could fall down. 	
		<p>*a Heavy load exceeding the weight limits or size limits of the engine lifter</p>

a.

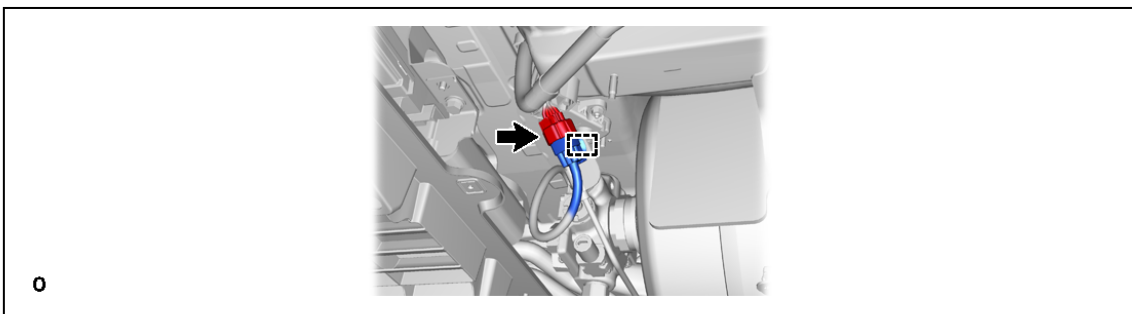

o

b.

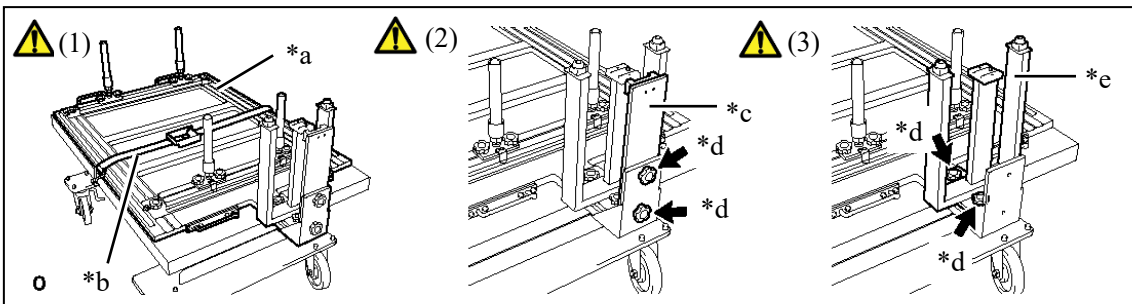

*a	SST (Hydrogen Tank Stand No. 2)	*b	Belt
*c	SST (Support No. 1)	*d	SST (Set Bolt A)
*e	SST (Support No. 2)	-	-

(1) Set SST (hydrogen tank stand No. 2) on the engine lifter and secure it with the belt.

SST

09403-62030

Notice:

Set SST (hydrogen tank stand No. 2) in the middle of the engine lifter and secure the center portion with the belt.

(2) Remove 2 SST (set bolt A) and SST (support No. 1).

SST

09403-62030 (09403-06200, 09403-06210)

(3) Remove 2 SST (set bolt A) and SST (support No. 2).

SST

09403-62030 (09403-06210, 09403-06220)

c.

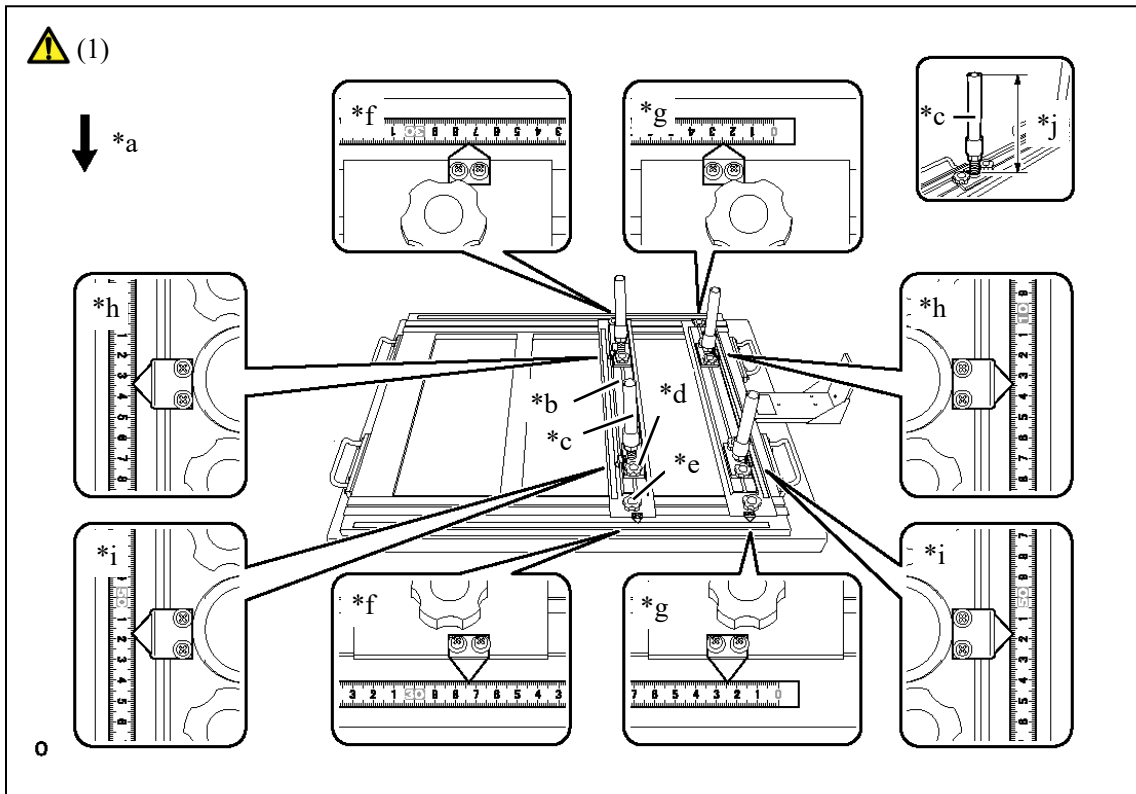

*a	Front side of vehicle	*b	SST (Support Rail No. 1)
*c	SST (Support No. 3)	*d	SST (Set Bolt C)
*e	SST (Set Bolt B)	*f	Scale surface: 273.5 mm (10.8 in.)
*g	Scale surface: 24.5 mm (0.965 in.)	*h	Scale surface: 134 mm (5.28 in.)
*i	Scale surface: 517.5 mm (20.4 in.)	*j	Front side of vehicle: 235 mm (9.25 in.) Rear side of vehicle: 248 mm (9.76 in.)

(1) Adjust SST (support No. 3), SST (support rail No. 1), and tighten SST (set bolt B), SST (set bolt C).

SST

09403-62030 (09403-06230, 09403-06240, 09403-06250, 09403-06260)

Hint:

This is done to align SST (hydrogen tank stand No. 2) with the installation condition of the No. 3 hydrogen tank assembly on the vehicle.

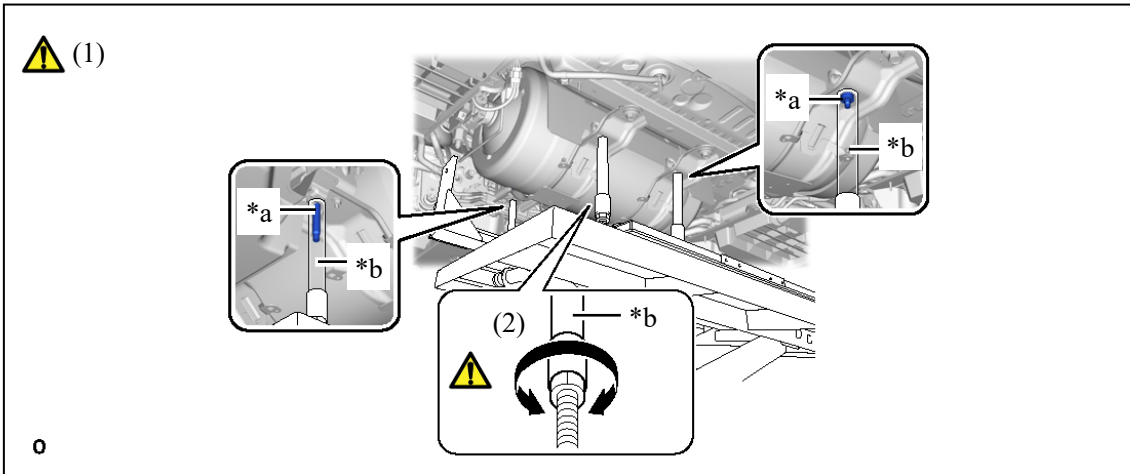

*a	Protrusion	*b	SST (Support No. 3)
----	------------	----	---------------------

- (1) Operate the engine lifter, and set SST (hydrogen tank stand No. 2) against the No. 3 hydrogen tank assembly.

Notice:

Align the protrusions of each No. 3 hydrogen tank frame sub-assembly with the holes of SST (support No. 3).

- (2) When the gap between the No. 3 hydrogen tank frame sub-assembly and SST (support No. 3) is large, rotate SST (support No. 3) to adjust the height.

e.

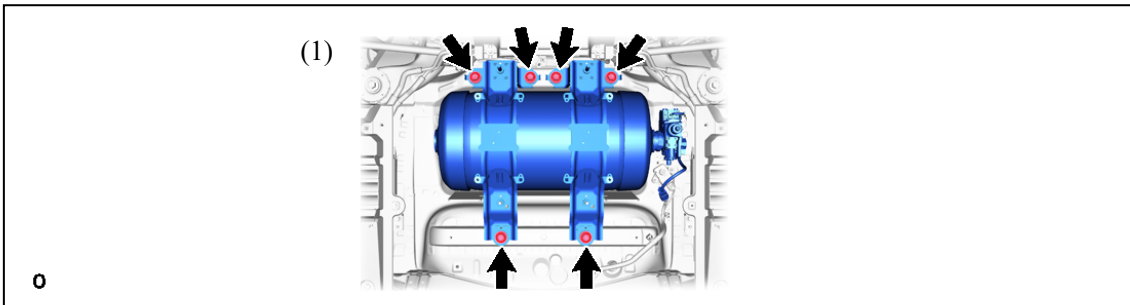

- (1) Remove the 6 bolts.
- (2) Operate the engine lifter and slowly remove the No. 3 hydrogen tank assembly from the vehicle.

Notice:

Make sure that the No. 3 hydrogen tank assembly does not interfere with the hydrogen tank tube.

47. REMOVE HYDROGEN TANK PROTECTOR PLATE (for 3 Hydrogen Tank)

a.

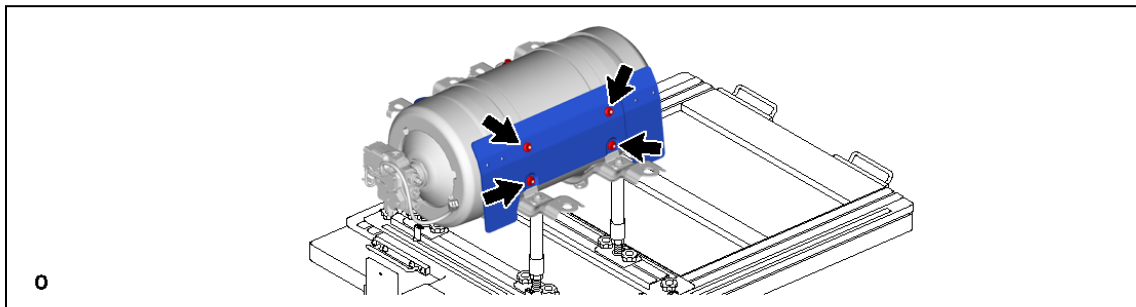

48. REMOVE NO. 3 HYDROGEN TANK SPRING BOLT CUP (for 3 Hydrogen Tank)

a.

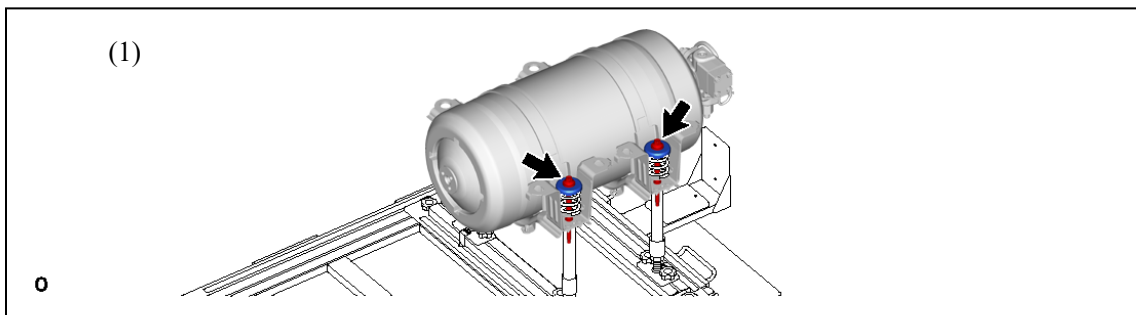

(1) Remove the 2 bolts, 2 No. 3 hydrogen tank spring bolt cups and 2 compression springs.

49. REMOVE NO. 3 HYDROGEN TANK BAND SUB-ASSEMBLY (for 3 Hydrogen Tank)

a.

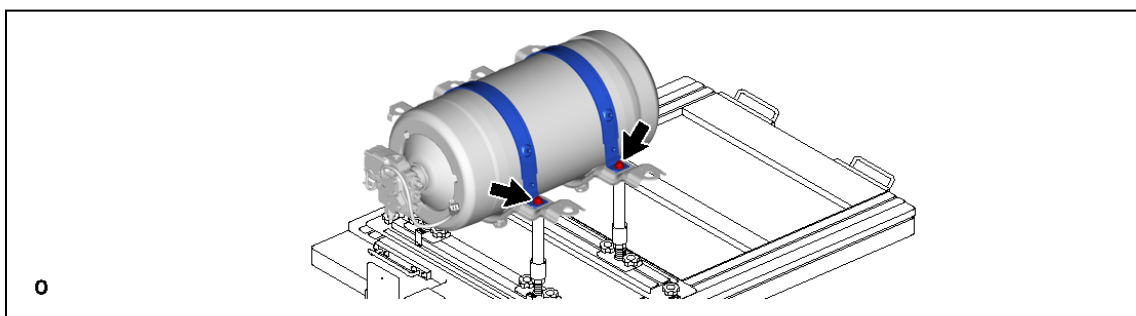

50. REMOVE NO. 3 HYDROGEN TANK ASSEMBLY (for 3 Hydrogen Tank)

a.

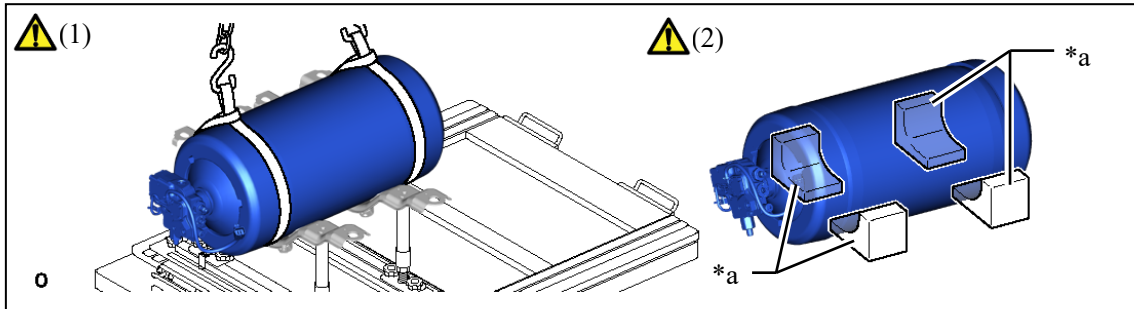

*a	Wheel Chocks	-	-
----	--------------	---	---

- (1) Using an engine sling device and belts, remove the No. 3 hydrogen tank assembly from the No. 3 hydrogen tank frame sub-assembly.

Caution:

- **When hoisting up the hydrogen tank assembly, do not hoist it when not properly balanced.**
- **The hydrogen tank assembly could fall, resulting in a serious accident.**

- (2) Place the No. 3 hydrogen tank assembly on wheel chocks or similar.

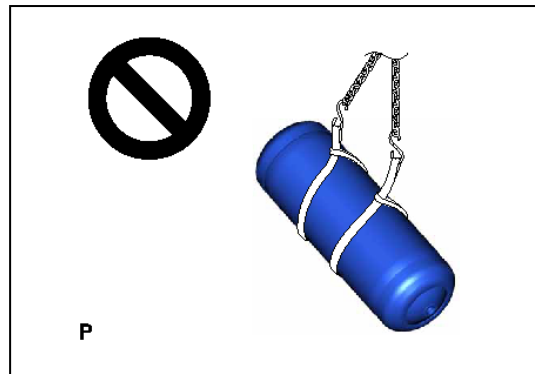

Dispose of Hydrogen Tank Assembly

Caution:

- Do not perform these procedures with the hydrogen tank assembly filled with compressed hydrogen gas.
- Because the hydrogen tank assembly is extremely heavy, be sure to perform these procedures with 2 people or more.
- Perform the procedures outdoors in a well-ventilated area.
- Do not perform the procedures within 8 meters of any ignition sources. (A distance of 10 meters or more is recommended.)
- To prevent static electricity, spray water on the hydrogen tank assembly and around the work area.
- Before performing work procedures, touch a metal object in contact with the ground in order to discharge any static electricity from your body.
- While releasing compressed hydrogen gas, the temperature inside the tank decreases and frost may form on the outside. Do not touch tanks or SST (hydrogen tank venting tool (high pressure)) when frost has formed on them.
- Touching tanks or SST (hydrogen tank venting tool (high pressure)) on which frost has formed could result in burn-like injuries due to frostbite.

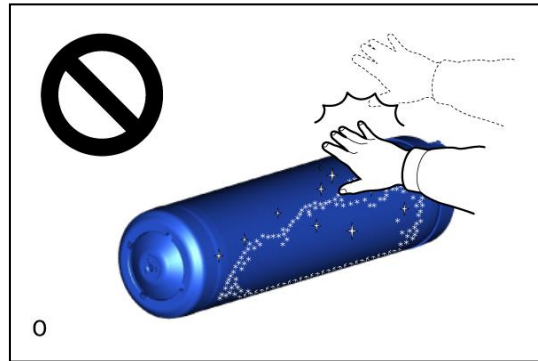

Hint:

Before performing this procedure, make sure that the compressed hydrogen gas has been fully released from the hydrogen tank assembly.

- b. Use a belt to secure the hydrogen tank assembly to the work table.

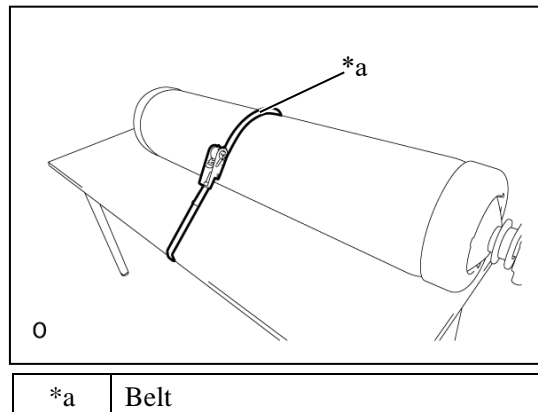

- c. Using a T20 "TORX" socket wrench, disconnect the 2 screws and disconnect the wire harness from the hydrogen tank valve assembly.

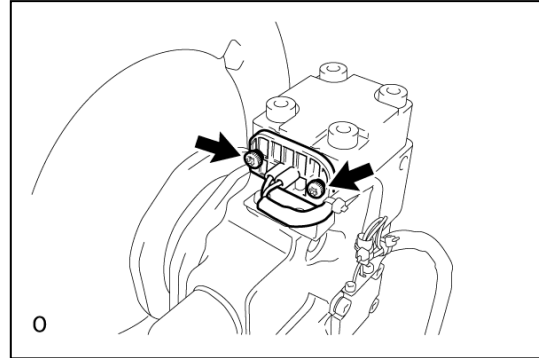

- d. Using a 13 mm socket wrench, install SST (hydrogen tank holding tool) to the hydrogen tank valve assembly.

SST

09403-62021 (09403-00010)

Torque:

28 N*m (286 kgf*cm, 21 ft.*lbf)

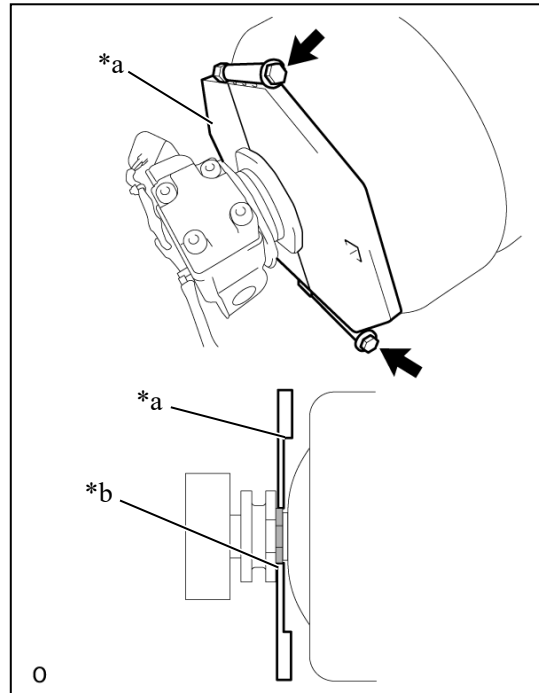

*a	SST
*b	SST Installation Area

- e. Remove the hydrogen tank valve assembly.
- (1) While holding SST (hydrogen tank holding tool), rotate the hydrogen tank valve assembly to loosen the valve.

Tightening torque (reference):
Hydrogen tank valve assembly
485 N*m (4946 kgf*cm, 358 ft.*lbf)

Caution:
Because the tightening torque of the hydrogen tank valve assembly is extremely high, perform this operation with 2 people.

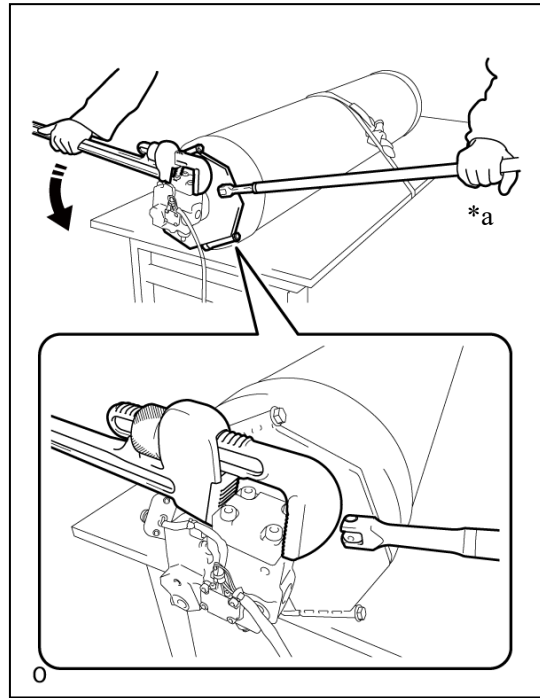

*a	Hold
▶▶▶	Turn

- (2) Remove SST (hydrogen tank holding tool) from the hydrogen tank valve assembly.

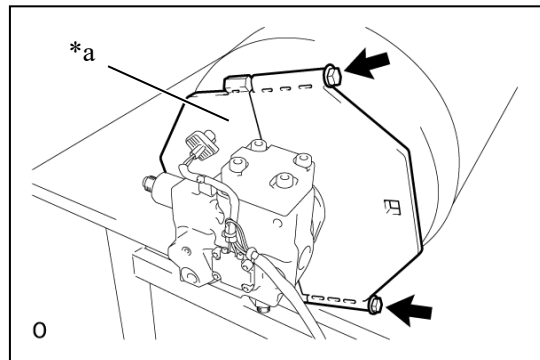

*a	SST
----	-----

- (3) Remove the hydrogen tank valve assembly.

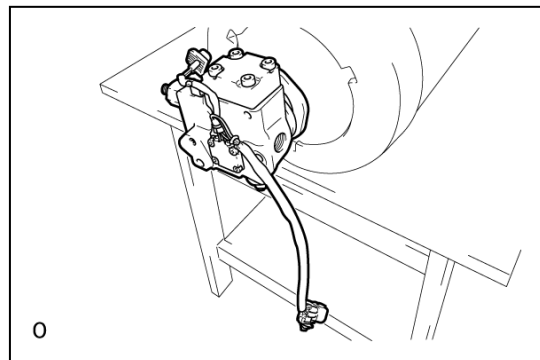

- f. Remove the hydrogen tank assembly from the work table.
- g. Soak the interior of the hydrogen tank assembly with water.

- (1) Spray water into the hydrogen tank assembly through the valve installation hole as shown in the illustration.

Notice:

To prevent static electricity from being generated when blowing compressed air into the hydrogen tank assembly through the valve installation hole, make sure to perform this procedure.

Hint:

Water filling amount: Approx. 10 L

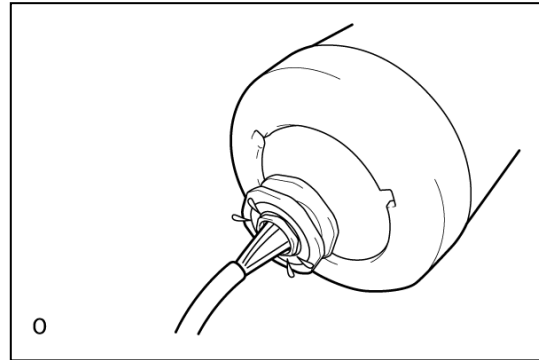

- (2) Rotate the hydrogen tank assembly 1 or more times so that the water is completely spread throughout the inside of the hydrogen tank assembly.

Notice:

To prevent static electricity from being generated when blowing compressed air into the hydrogen tank assembly through the valve installation hole, make sure to perform this procedure.

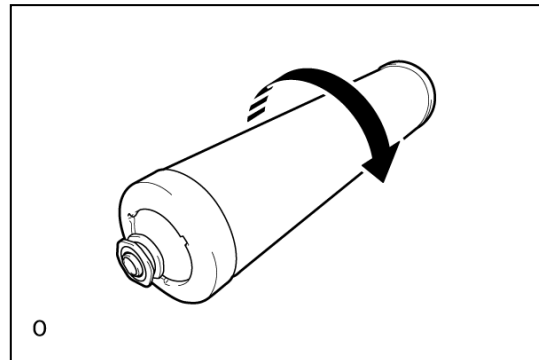

- h. Use a belt to secure the hydrogen tank assembly vertically

Caution:

Because the hydrogen tank assembly is extremely heavy, be sure to perform these procedures with 2 people or more.

Notice:

To prevent the hydrogen tank assembly from falling over, use a belt to secure the hydrogen tank assembly.

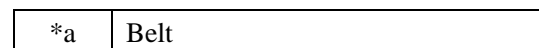
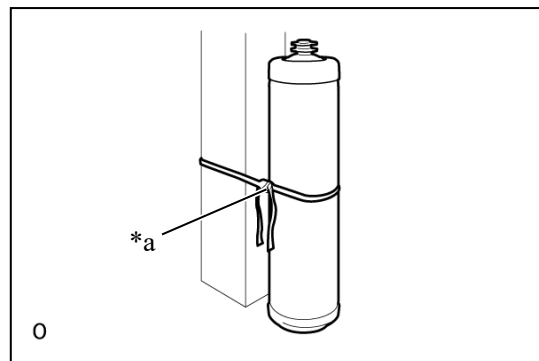

i. Measure the hydrogen gas concentration.

- (1) Before measuring the hydrogen gas concentration, blow compressed air into the hydrogen tank assembly through the hydrogen tank valve installation hole.

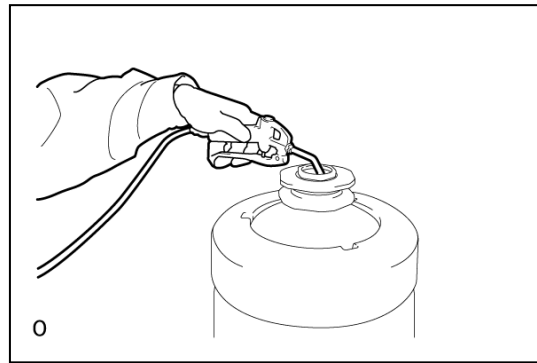

Hint:

Perform in order to force out hydrogen gas that may remain in the hydrogen tank assembly and release it into the atmosphere.

- (2) If there are any water droplets, etc. adhering to the measurement locations, wipe them away before measuring the hydrogen gas concentration.

Notice:

Performing the measurement while any water droplets, etc. are adhering could damage the hydrogen gas detector.

- (3) Using SST and a hydrogen gas detector, measure the hydrogen gas concentration at the location shown in the illustration.

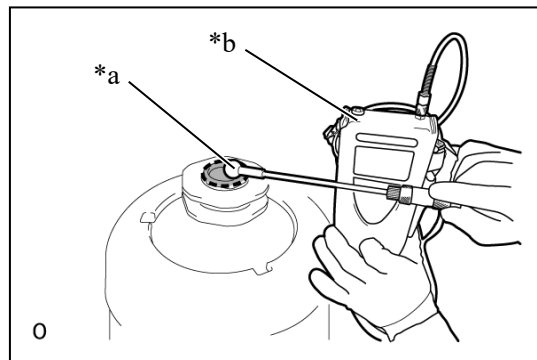

SST

09401-62020

Specified value:

Less than 500 ppm

Hint:

- If the hydrogen tank assembly is left standing vertically for approximately 1 day, the hydrogen concentration becomes 500 ppm or less. (Make sure to leave it in an area with good ventilation for at least 8 hours.)
- Immediately after the measurement starts, the measured value may be unstable.
- Measure the gas concentration for approximately 10 seconds continuously.

*a	SST
*b	Hydrogen Gas Detector
	Hydrogen Concentration Measurement Area

- j. Place the hydrogen tank assembly on wheel chocks or similar.

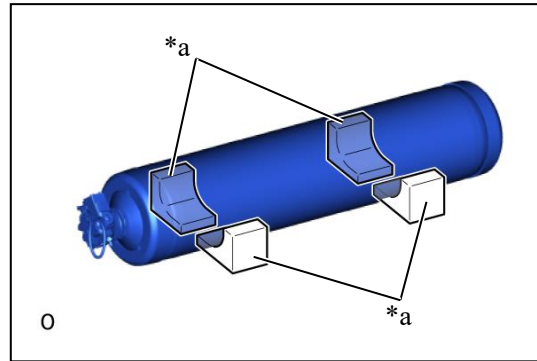

*a	Wheel Chocks
----	--------------

- k. Using a drill, open 2 or more holes on the hydrogen tank assembly.

Hole diameter:

12.5 mm (0.492 in.) or more

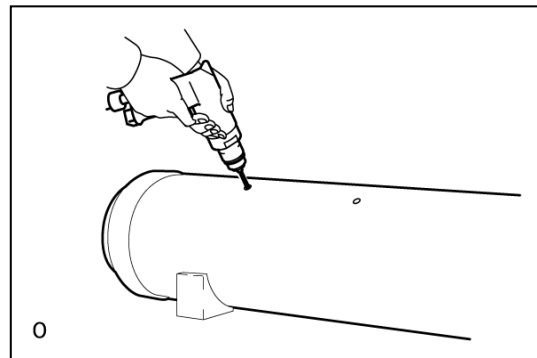

Caution:

- **Make sure to wear protective glasses when drilling the holes.**
- **Drilling the holes without wearing protective glasses could result in a serious accident.**

Hint:

Perform this procedure so that the hydrogen tank assembly is not reused.



- l. Destroy the threads of the valve installation hole of the hydrogen tank assembly as shown in the illustration.

Hint:

Perform this procedure so that the hydrogen tank assembly is not reused.

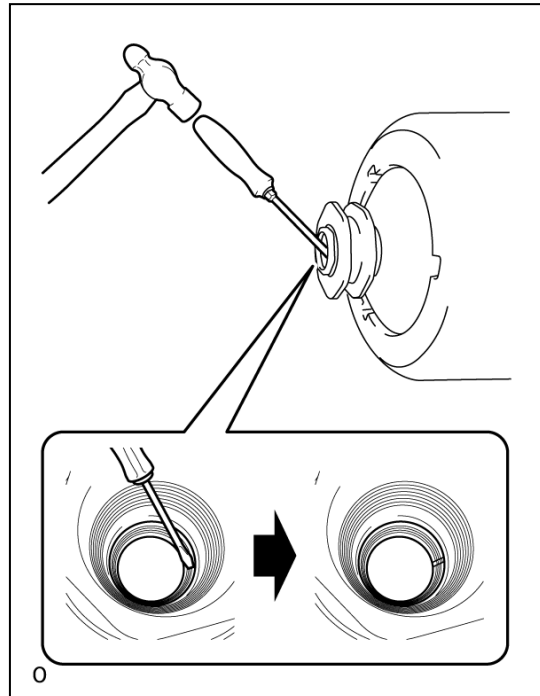

- m. Destroy the threads of the valve of the hydrogen tank assembly as shown in the illustration.

Hint:

Perform this procedure so that the hydrogen tank valve assembly is not reused.

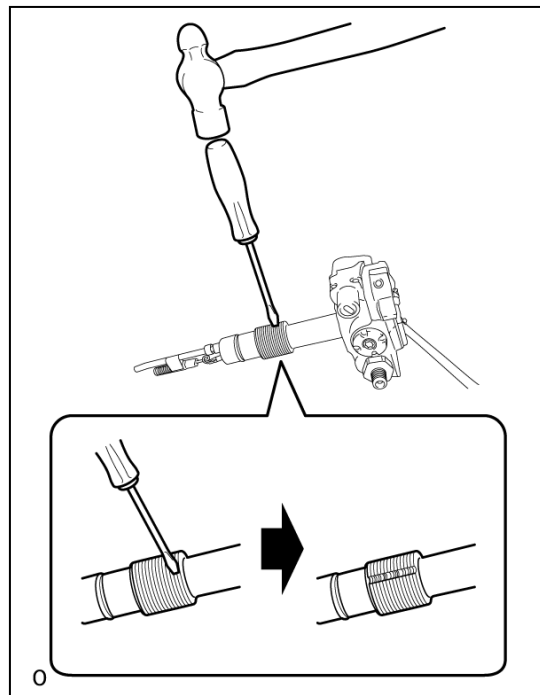

Removal of FC Converter with FC Stack Assembly

1. CAUTIONS FOR HIGH VOLTAGE SYSTEM COMPONENTS

	<p>NOTICE:</p> <ul style="list-style-type: none">• Do not allow foreign matter to enter the opening of the connector.• Do not touch the connector terminals.• Do not turn the power switch on (READY) before filling the coolant (for inverter).• When turning power switch on (IG), do not also turn the power switch on (READY).• Do not apply oil or grease to the bolts.
---	---

2. REMOVE FRONT WIPER ARM HEAD CAP

a.

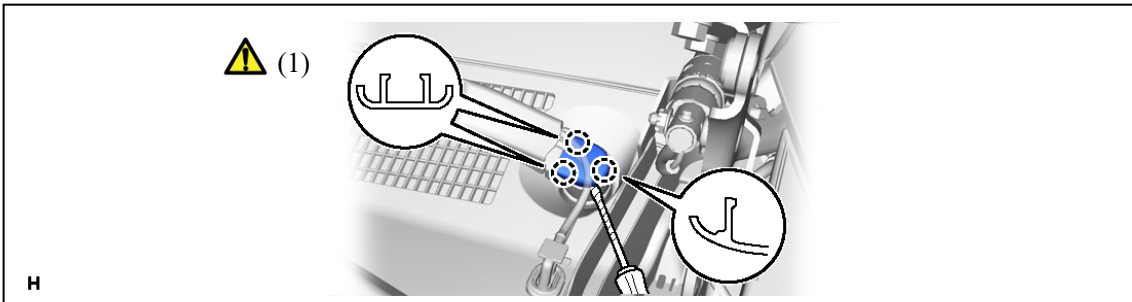

(1) Using a screwdriver, disengage the 3 claws as shown in the illustration to remove the front wiper arm head cap.

Hint:

Use the same procedure for the RH side and LH side.

3. REMOVE FRONT WIPER ARM AND BLADE ASSEMBLY RH

a.

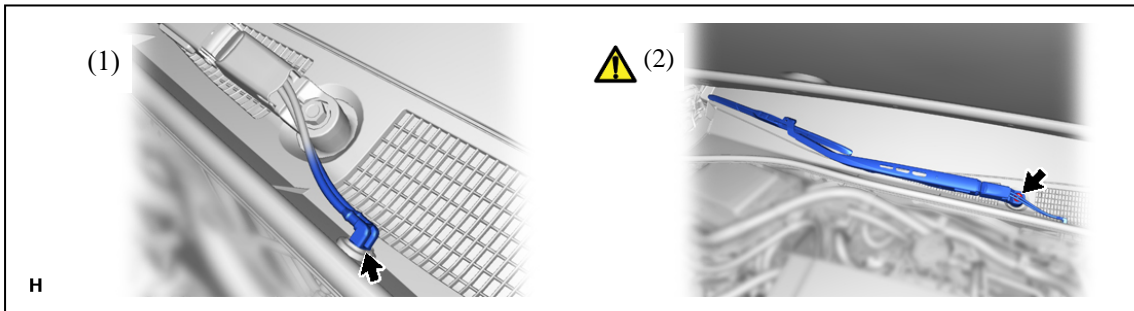

(1) Disconnect the 2 windshield washer hose assemblies.

(2) Remove the nut and front wiper arm and blade assembly RH.

Hint:

While holding the front wiper arm and blade assembly RH, loosen the nut.

4. REMOVE FRONT WIPER ARM AND BLADE ASSEMBLY LH

a.

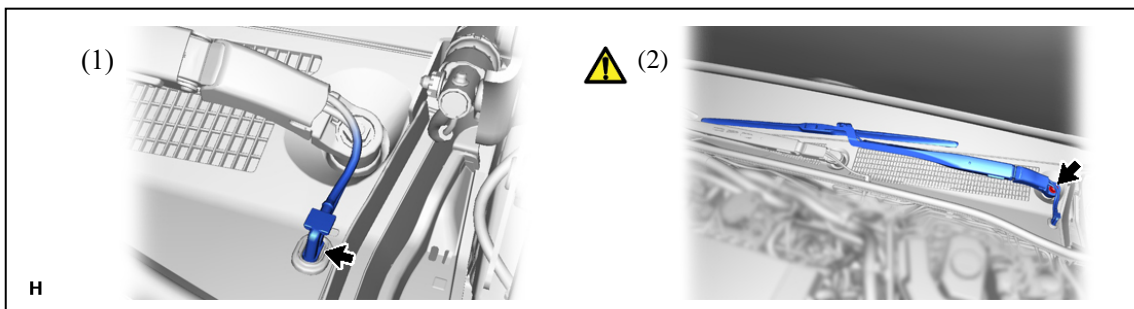

(1) Disconnect the 2 windshield washer hose assemblies.

(2) Remove the nut and the front wiper arm and blade assembly LH.



Hint:

While holding the front wiper arm and blade assembly LH, loosen the nut.

5. REMOVE FRONT FENDER UPPER PROTECTOR LH

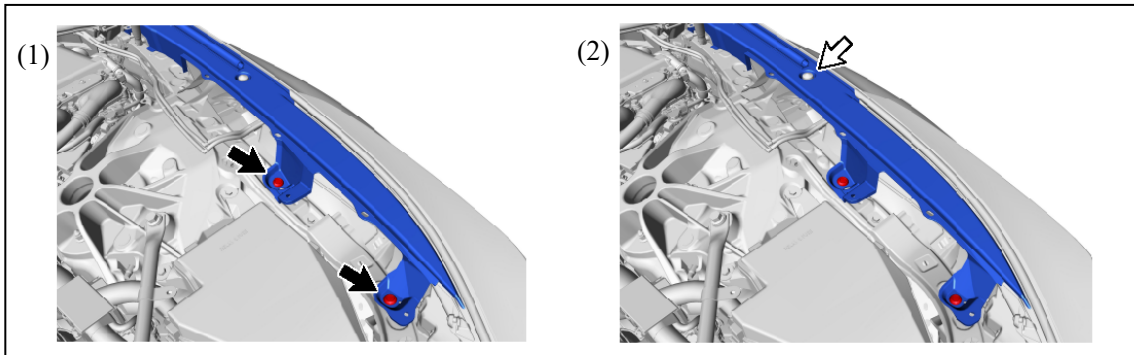
a.





	Clip		Center Hood Cushion
---	------	---	---------------------

- (1) Remove the 2 clips.
- (2) Remove the center hood cushion.

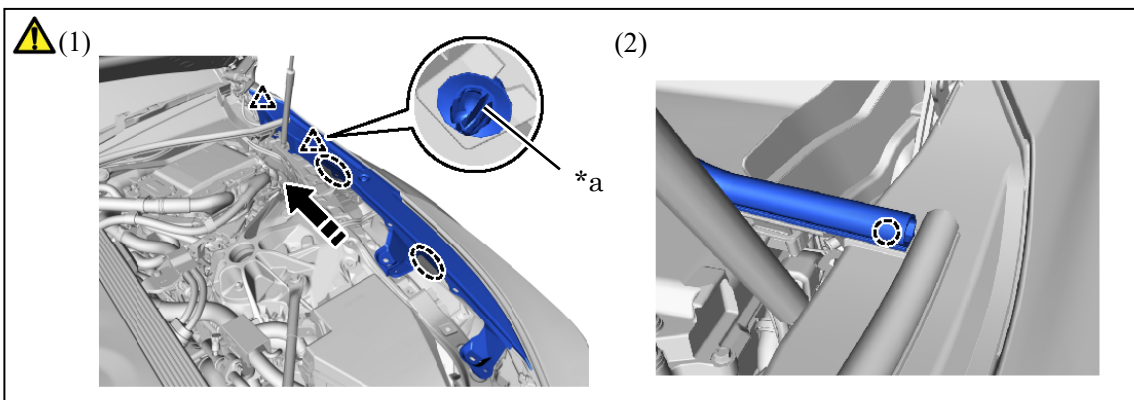
b.



*a	Seat	-	-
	Place Hand Here		Move in this Direction

- (1) Hold the areas shown in the illustration and pull toward the rear of the vehicle to disconnect the seat from the clip.
- (2) Detach the claw of the hood to cowl top seal and remove the front fender protector upper LH.

6. REMOVE COWL TOP VENTILATOR LOUVER PROTECTOR RH

a.

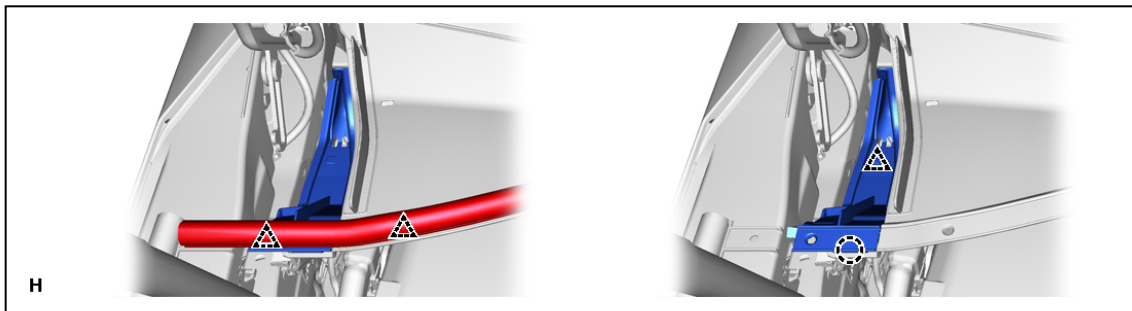

7. REMOVE COWL TOP VENTILATOR LOUVER PROTECTOR LH

a.

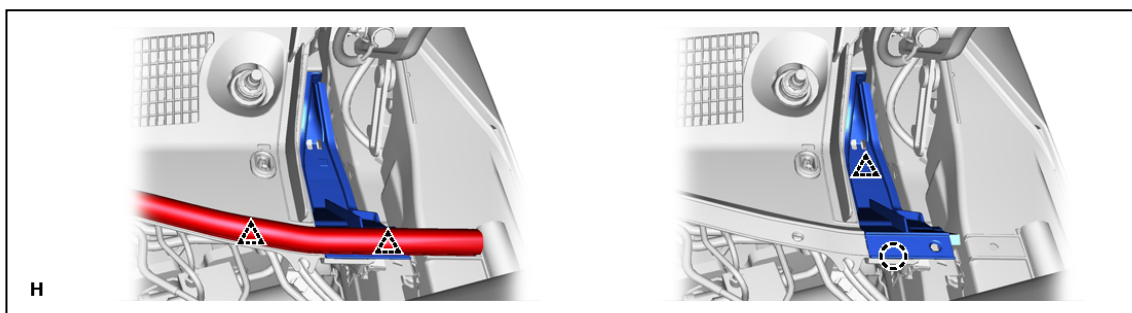

8. REMOVE LOWER WINDSHIELD MOULDING OUTSIDE LH

a.

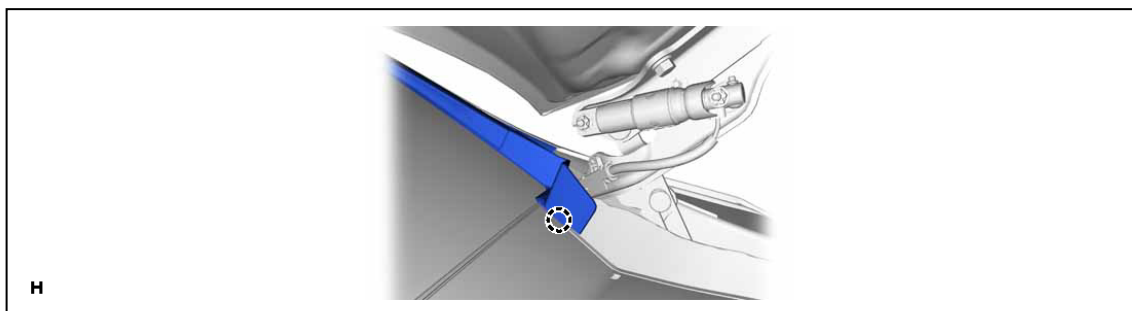

9. REMOVE LOWER WINDSHIELD MOULDING OUTSIDE

a.

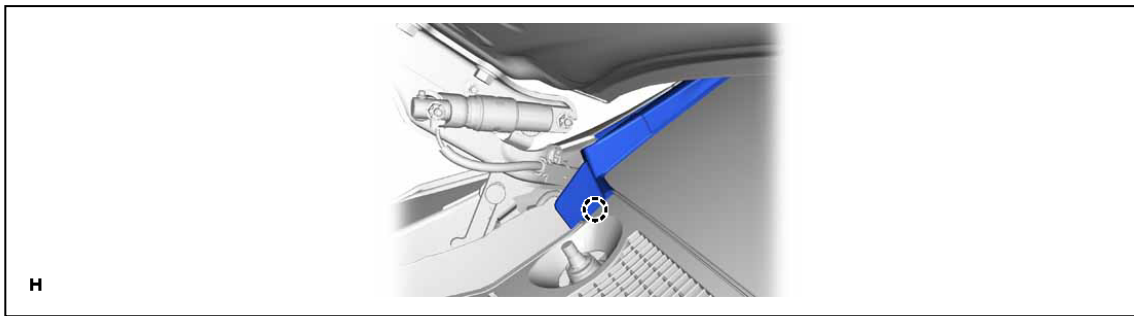

10. REMOVE COWL TOP VENTILATOR LOUVER SUB-ASSEMBLY

a.

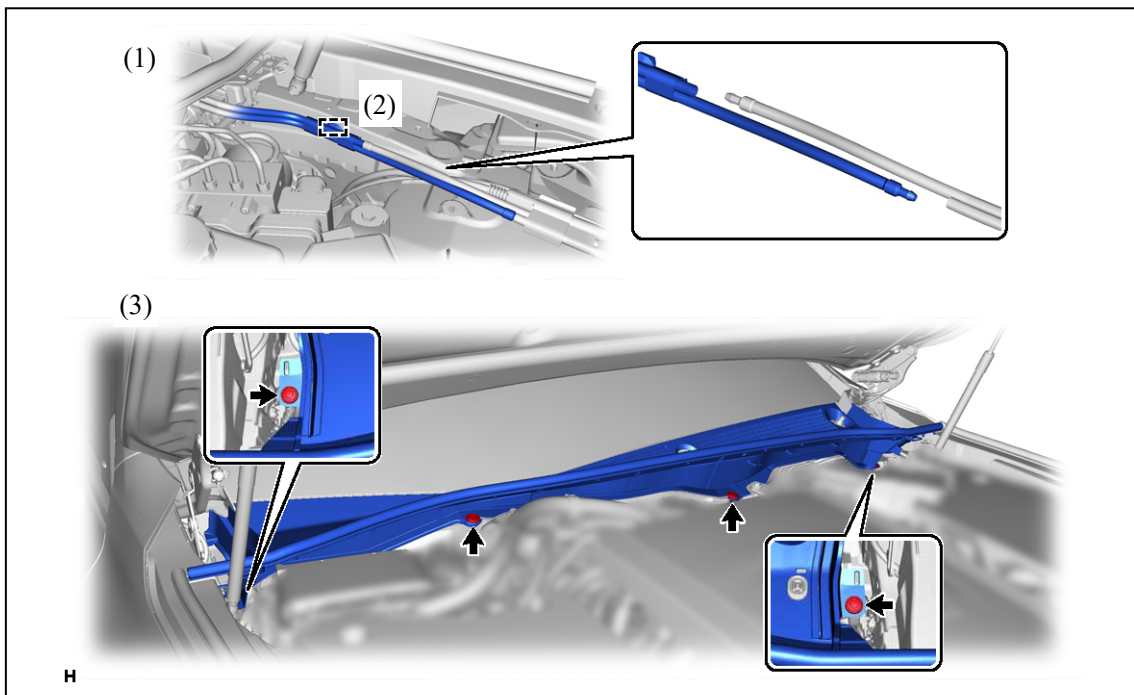

- (1) Disconnect the 2 windshield washer hose assemblies as shown in the illustration.
- (2) Disconnect the clamp.
- (3) Remove the 4 clips.

b.

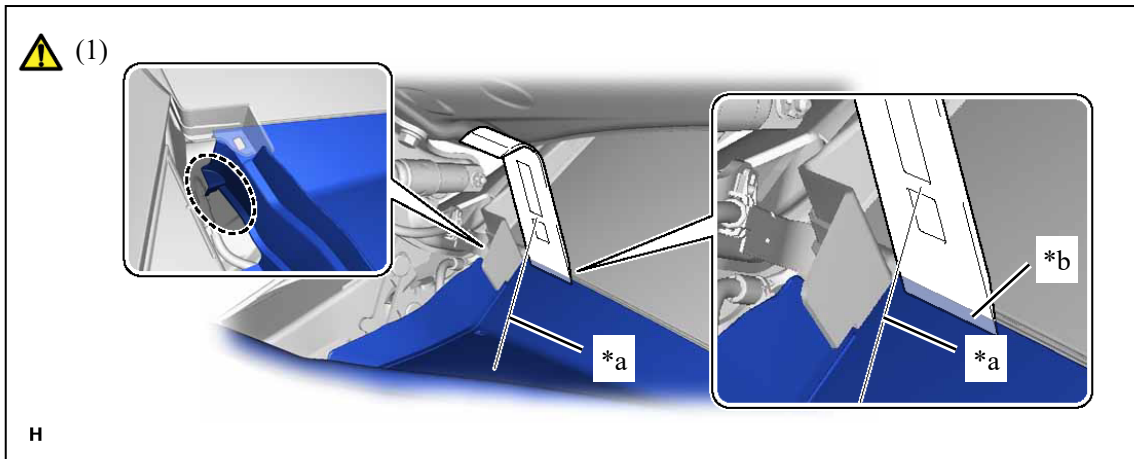

*a	Starting Position: Side of Cowl Top Ventilator Louver Sub-assembly and Moulding Remover Aligned	*b	Inserted as Far as Possible
	Place Hand Here	-	-

- (1) Insert a moulding remover at the starting position, as far as it can be inserted, to lift the cowl top ventilator louver sub-assembly and then hold it as shown in the illustration.

c.

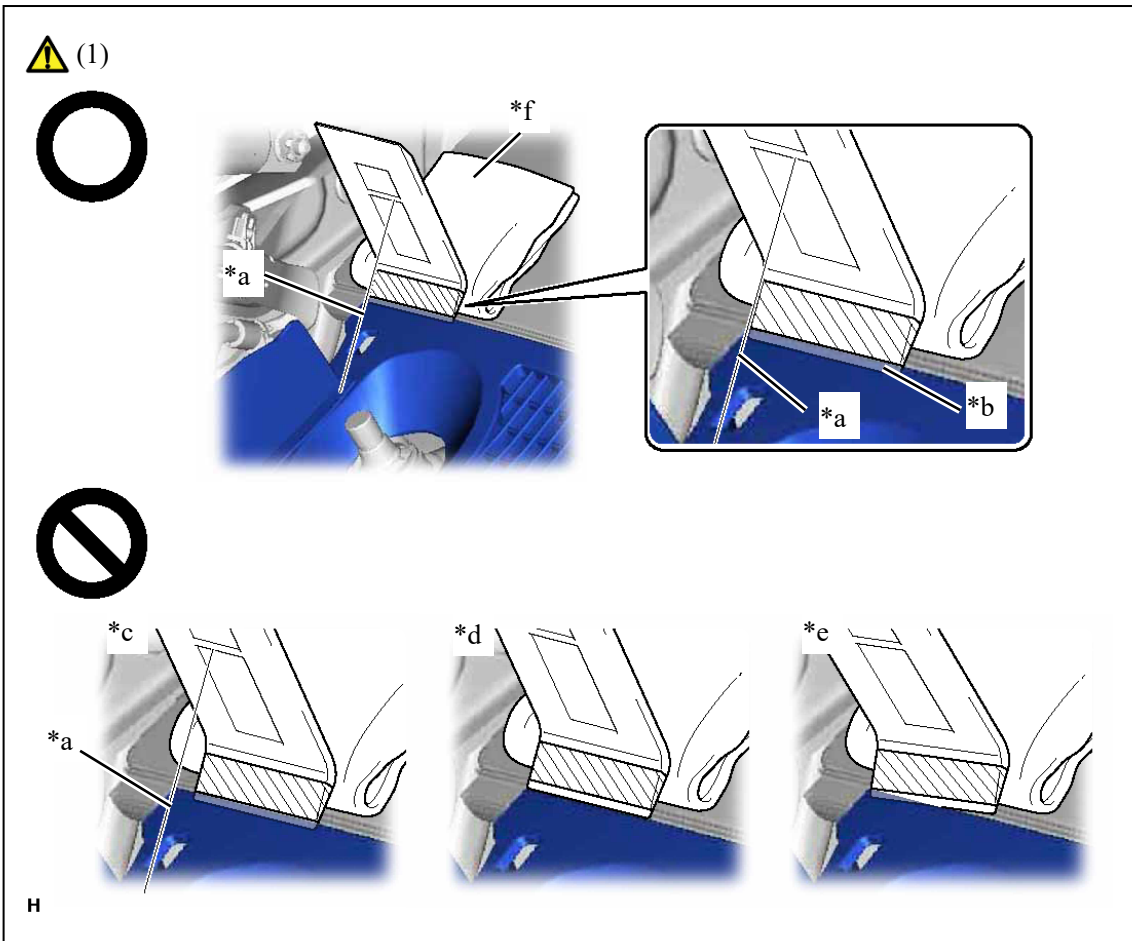



*a	Starting Position: Side of Cowl Top Ventilator Louver Sub-assembly and Moulding Remover Aligned	*b	Inserted to Edge of Protective Tape
*c	Not Inserted at Starting Position	*d	Not Inserted to Edge of Protective Tape
*e	Not Inserted Straight	*f	Piece of Cloth or Equivalent
	Protective Tape	-	-

(1) Insert the moulding remover at the starting position until the edge of the protective tape is aligned with the cowl top ventilator louver sub-assembly as shown in the illustration

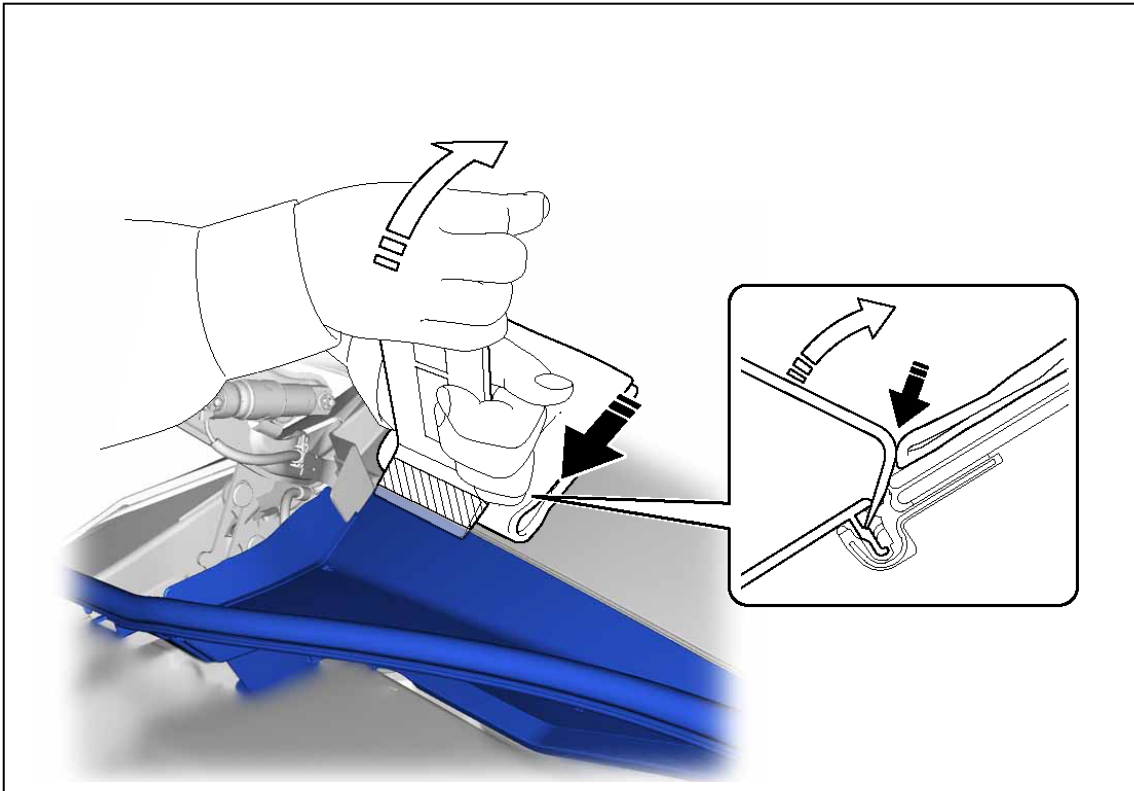
d.



	Push in this Direction (A)		Push in this Direction (B)
---	----------------------------	---	----------------------------

- (1) While pushing the moulding remover in the direction indicated by the arrow (A), push the moulding remover in the direction indicated by the arrow (B) to disengage the cowl top ventilator louver sub-assembly.

Notice:

Make sure to repeat this procedure to disengage the entire cowl top ventilator louver sub-assembly.

e.

 (1)

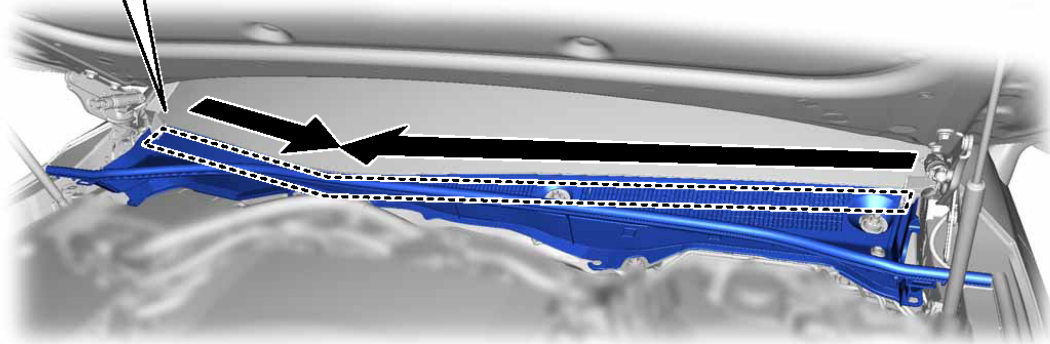
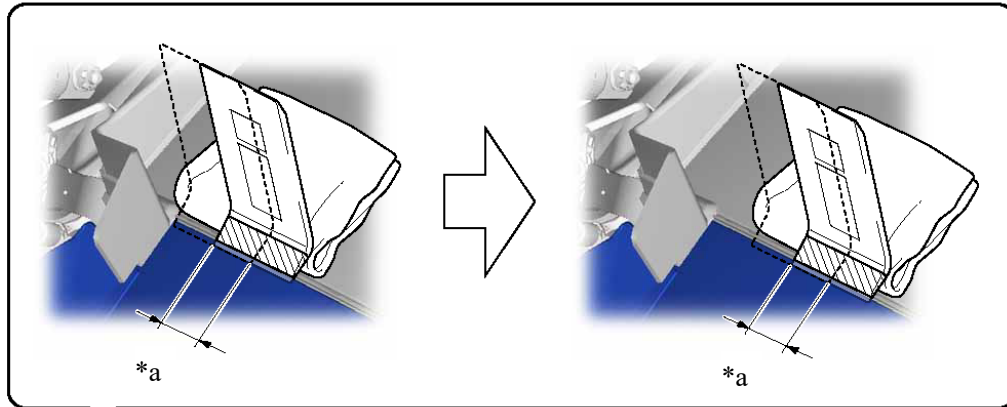



H

*a	Half Width of Moulding Remover	-	-
	Order of Removal	-	-

- (1) Using the moulding remover, repeatedly pry up the cowl top ventilator louver sub-assembly while gradually moving the moulding remover half of its width laterally toward the center of the vehicle and then repeat the procedure from the other side of the vehicle as shown in the illustration to disengage the cowl top ventilator louver sub-assembly from the windshield glass.

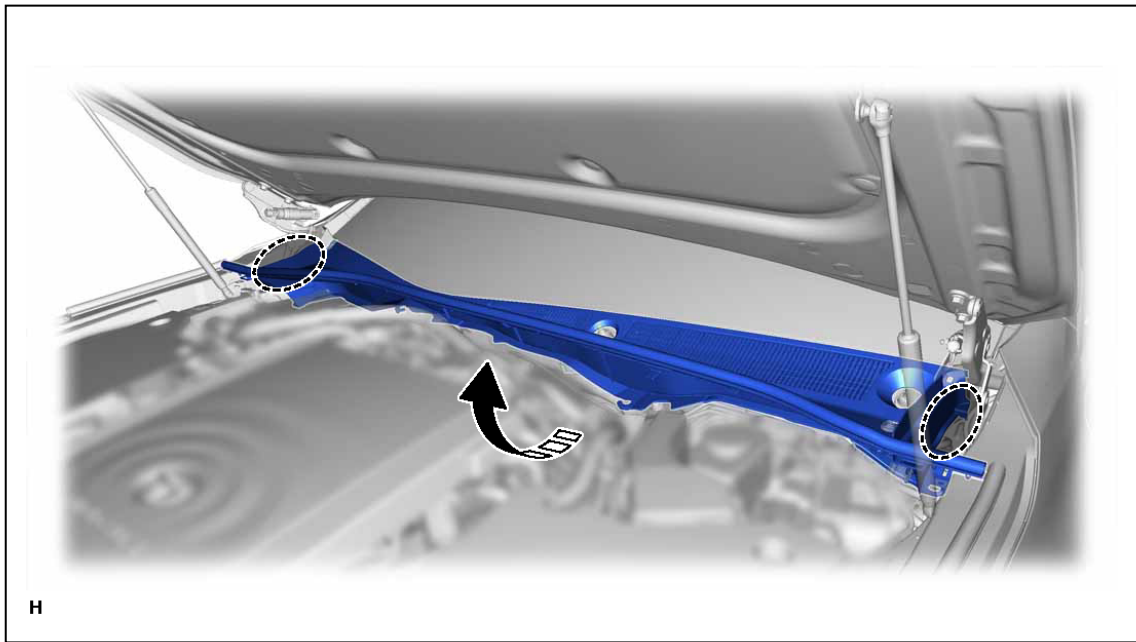
f.



	Place Hand Here		Remove in this Direction
---	-----------------	---	--------------------------

- (1) Pull the front of the cowl top ventilator louver sub-assembly upward and rotate it as shown in the illustration, and remove the cowl top ventilator louver sub-assembly.

11. REMOVE FRONT COMPARTMENT UNDER COVER

a.

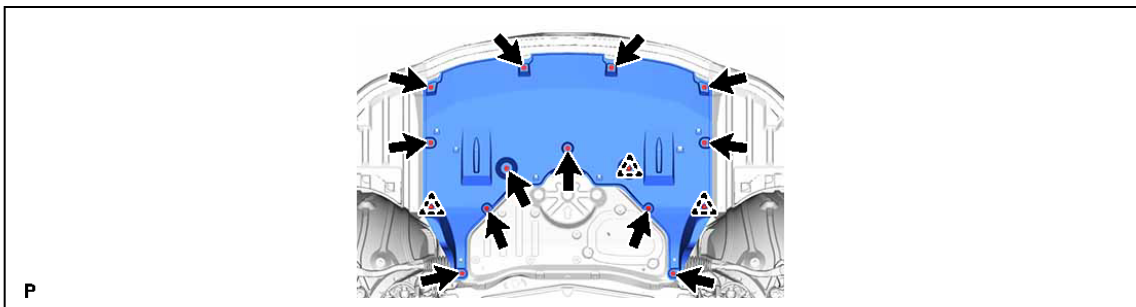

12. REMOVE FRONT LOWER SUSPENSION MEMBER PROTECTOR

a.

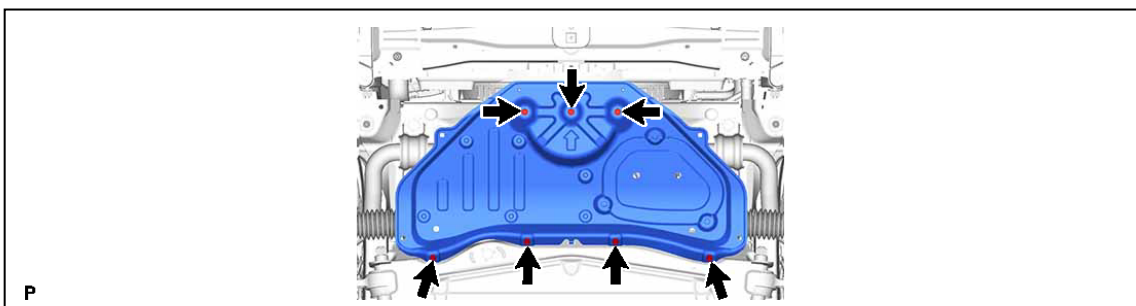

13. REMOVE FRONT COMPARTMENT UNDER COVER ASSEMBLY

a.

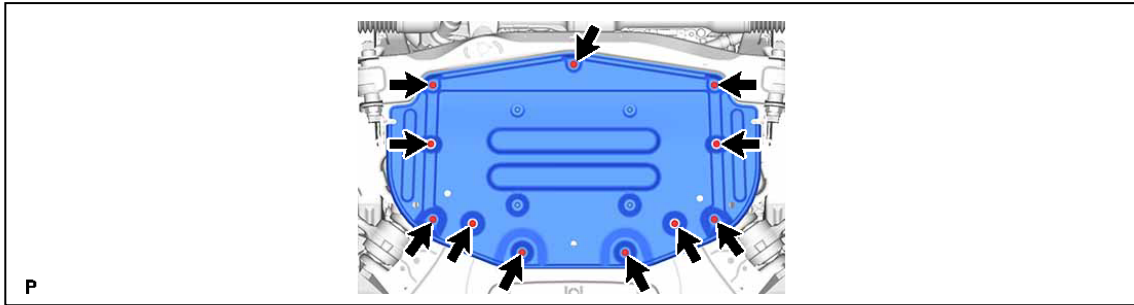

14. DISCONNECT NO. 2 HYDROGEN SUPPLY TUBE SUB-ASSEMBLY (IF EQUIPPED)

a.

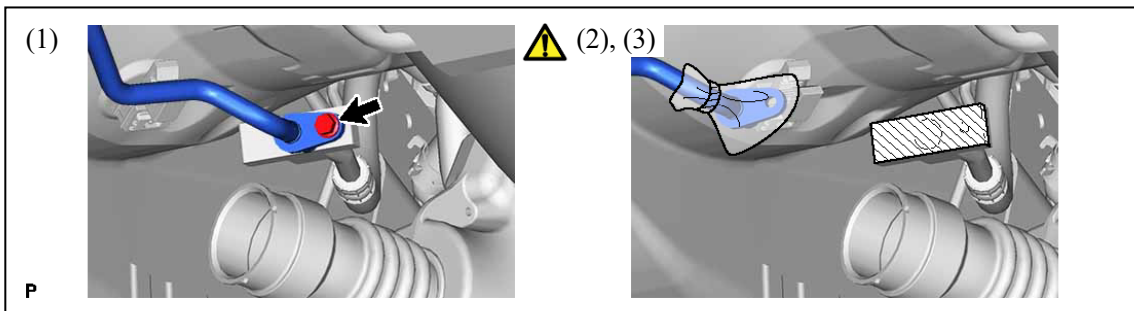

- (1) Remove the bolt and No. 2 hydrogen supply tube sub-assembly.
- (2) Cover the connection of the No. 2 hydrogen supply tube sub-assembly with plastic bags to prevent the foreign matter.
- (3) Protect the openings of the No. 1 hydrogen supply tube sub-assembly with protective tape (non-residue type) to prevent the entry of foreign matter or water.

15. REMOVE INVERTER TERMINAL COVER

	<p>CAUTION: Wear insulated gloves.</p> <p>NOTICE:</p> <ul style="list-style-type: none">• Make sure to pull the inverter terminal cover straight up, as a connector is connected to the bottom of the cover.• Do not touch the inverter terminal cover waterproofing rubber.• Do not allow any foreign matter or water to enter the inverter with converter assembly.
---	--

a.

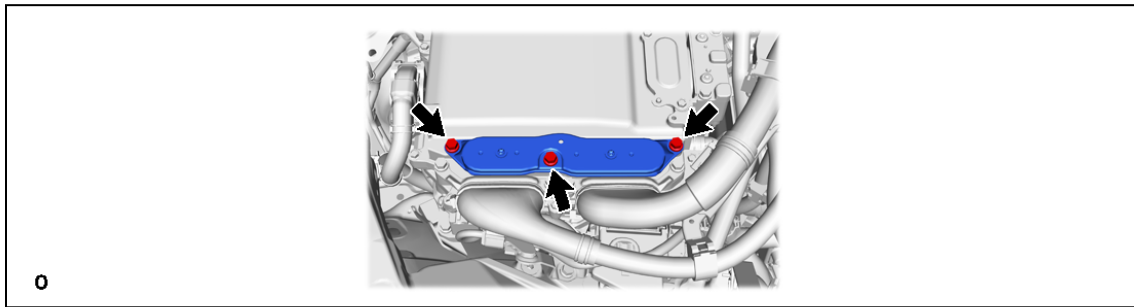

16. DISCONNECT FC AIR COMPRESSOR MOTOR CABLE ASSEMBLY



CAUTION:
Wear insulated gloves.

a.

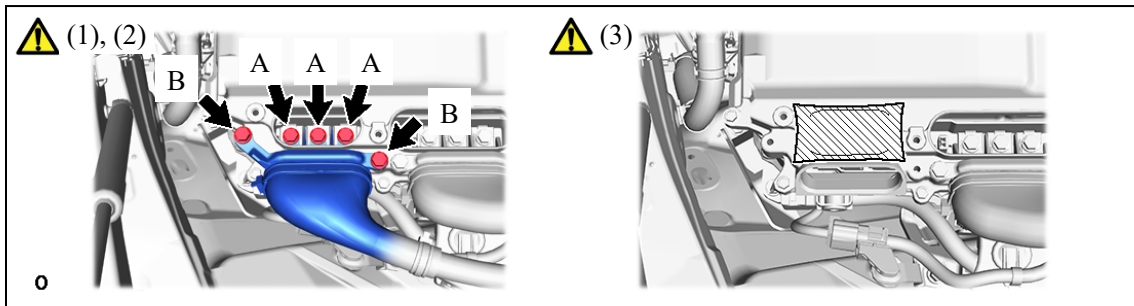

- (1) Using an insulated tool, remove the 3 bolts (A).
- (2) Using an insulated tool, remove the 2 bolts (B), and disconnect the FC air compressor motor cable assembly from the inverter with converter assembly.

Notice:

- Do not allow any foreign matter or water to enter the inverter with converter assembly.
 - Do not touch the connector waterproofing rubber or terminals.
 - Do not damage the terminals, connector housings or inverter with converter assembly during disconnection.
 - Insulate the disconnected terminals with insulating tape.
 - Cover the hole where the cable was connected with tape (non-residue type) or equivalent to prevent entry of foreign matter.
- (3) Protect the openings of the inverter with converter assembly with protective tape (non-residue type) to prevent the entry of foreign matter or water.

17. DISCONNECT NO. 2 BATTERY PACK WIRE



CAUTION:
Wear insulated gloves.

a.

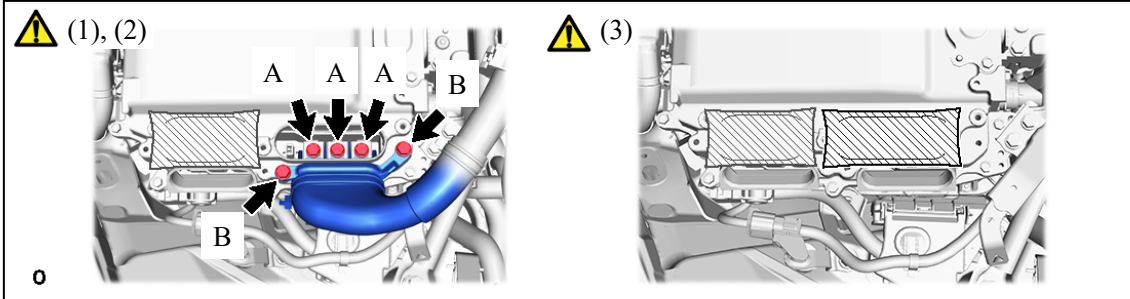

- (1) Using an insulated tool, remove the 3 bolts (A).
- (2) Using an insulated tool, remove the 2 bolts (B), and disconnect the No. 2 battery pack wire from the inverter with converter assembly.

Notice:

- Do not allow any foreign matter or water to enter the inverter with converter assembly.
 - Do not touch the connector waterproofing rubber or terminals.
 - Do not damage the terminals, connector housings or inverter with converter assembly during disconnection.
 - Insulate the disconnected terminals with insulating tape.
 - Cover the hole where the cable was connected with tape (non-residue type) or equivalent to prevent entry of foreign matter.
- (3) Protect the openings of the inverter with converter assembly with protective tape (non-residue type) to prevent the entry of foreign matter or water.

18. REMOVE INVERTER MOTOR CABLE BRACKET ASSEMBLY



CAUTION:
Wear insulated gloves.

a.

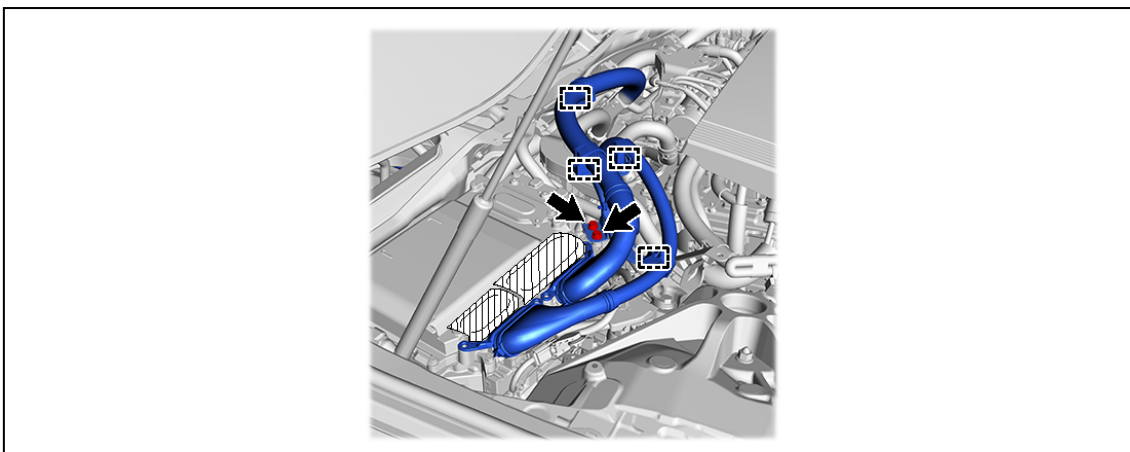

19. DISCONNECT FC CONVERTER POWER OUTLET CABLE (INVERTER WITH CONVERTER ASSEMBLY)



CAUTION:
Wear insulated gloves.

a.

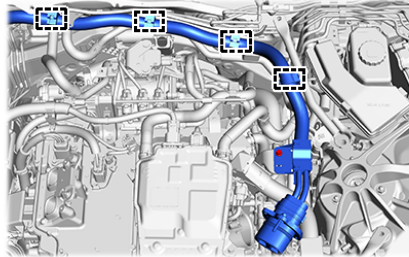

20. REMOVE FENDER APRON BRACE SUB-ASSEMBLY RH

a.

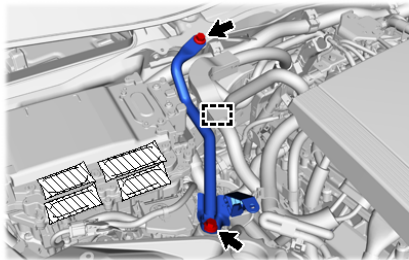

21. DRAIN COOLANT (for Inverter)



CAUTION:

- **To avoid the danger of being burned, do not remove the reserve tank cap or drain cock plug while the coolant (for inverter) is still hot.**
- **Pressurized, hot coolant (for inverter) and steam may be released and cause serious burns.**

- (1) Remove the inverter reserve tank cap from the inverter reserve tank assembly.
- (2) Connect a hose to the drain cock as shown in the illustration.
- (3) Loosen the drain cock plug and drain the coolant.
- (4) Tighten the drain cock plug.
- (5) Disconnect the hose from the radiator drain cock.

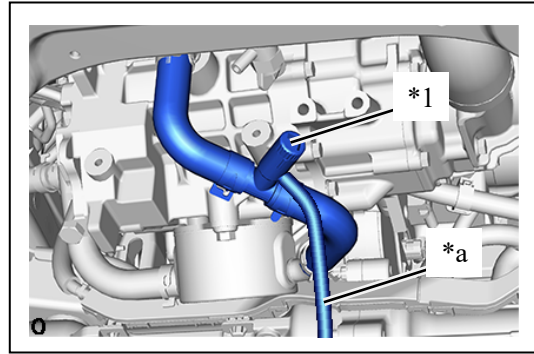

*1	Drain Cock Plug
*a	Hose

22. RECOVER REFRIGERANT FROM REFRIGERATION SYSTEM

- a. Recover the refrigerant from the A/C system using a refrigerant recovery unit.

Hint:

Use the refrigerant recovery unit in accordance with the manufacturer's instruction manual.

23. REMOVE RADIATOR SUPPORT TO CROSS MEMBER BRACE SUB-ASSEMBLY LH

- a.

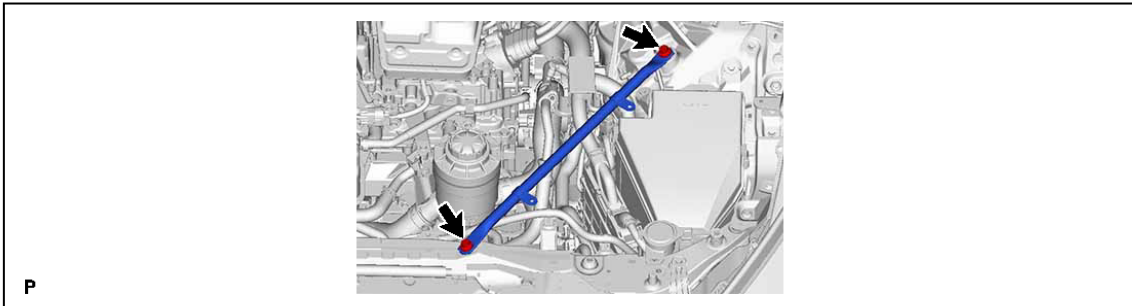

24. REMOVE RADIATOR SUPPORT TO CROSS MEMBER BRACE SUB-ASSEMBLY RH

- a.

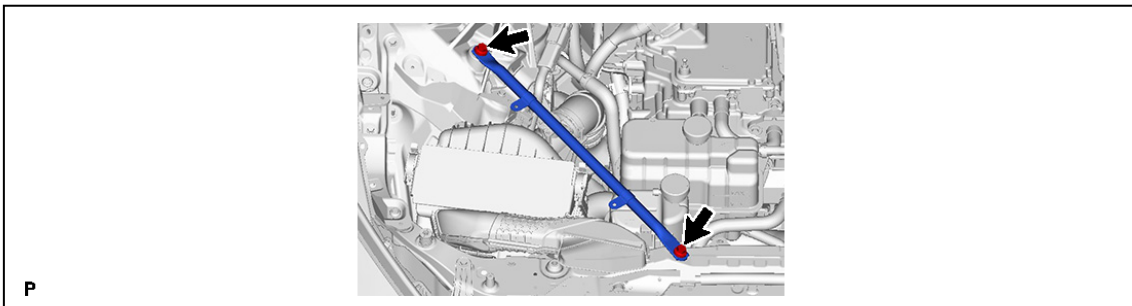

25. REMOVE AIR CLEANER WITH ELEMENT ASSEMBLY WITH AIR CLEANER INLET

a.

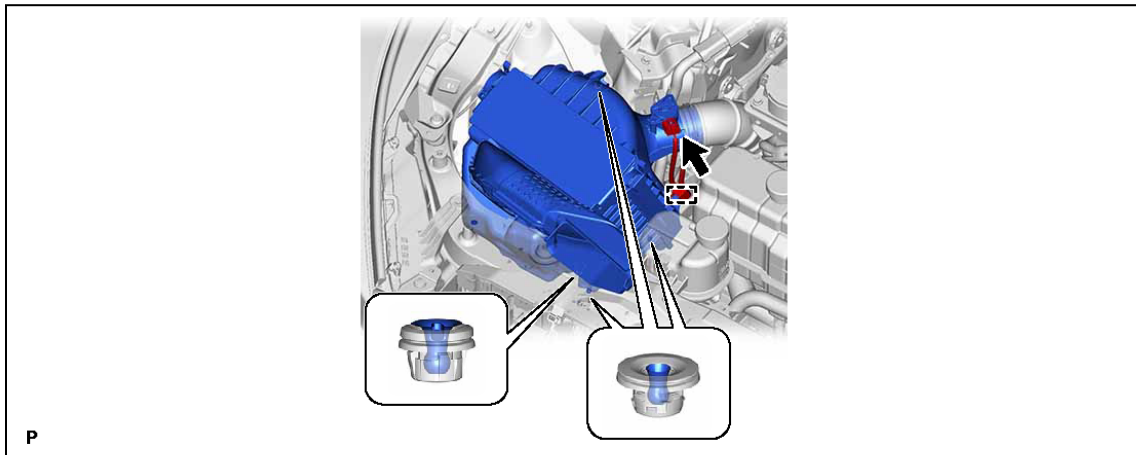

26. REMOVE AIR CLEANER INLET

a.

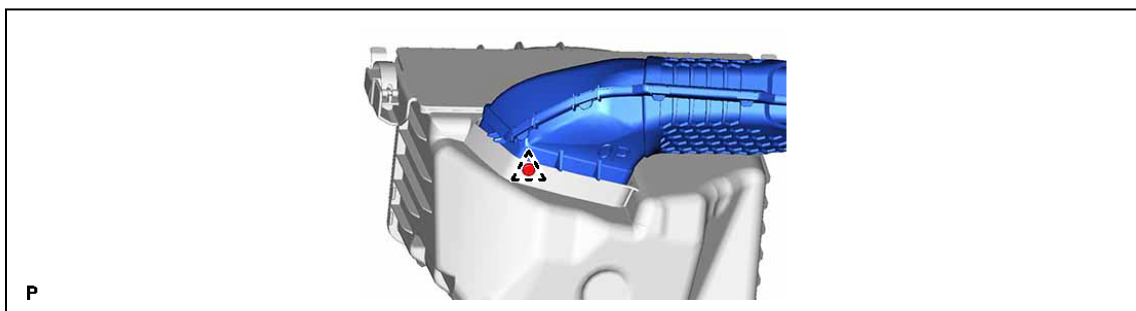

27. REMOVE FC CONTROL ECU

a.

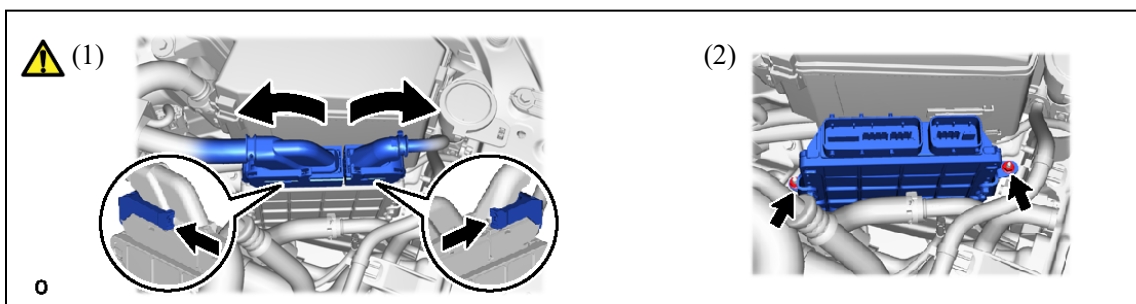

- (1) Lift up the lever to detach the lock, and disconnect the 2 FC control ECU connectors from the FC control ECU.
- (2) Remove the 2 bolts and FC control ECU.

28. REMOVE NO. 2 RELAY BLOCK COVER

a.

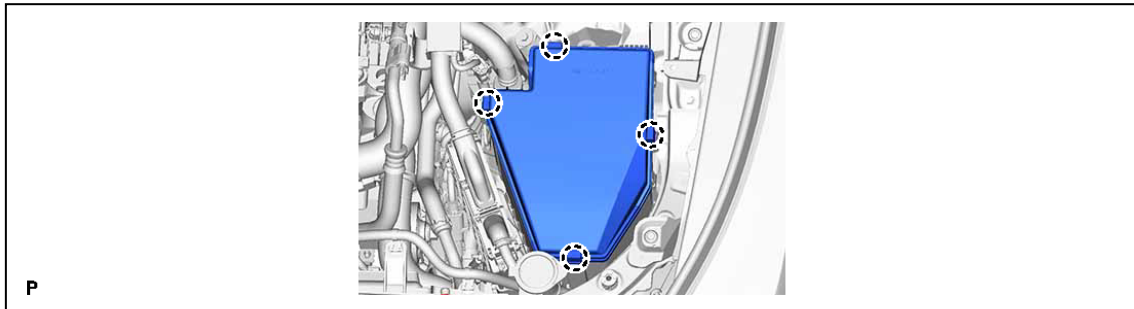

29. REMOVE WIRE HARNESS

a.

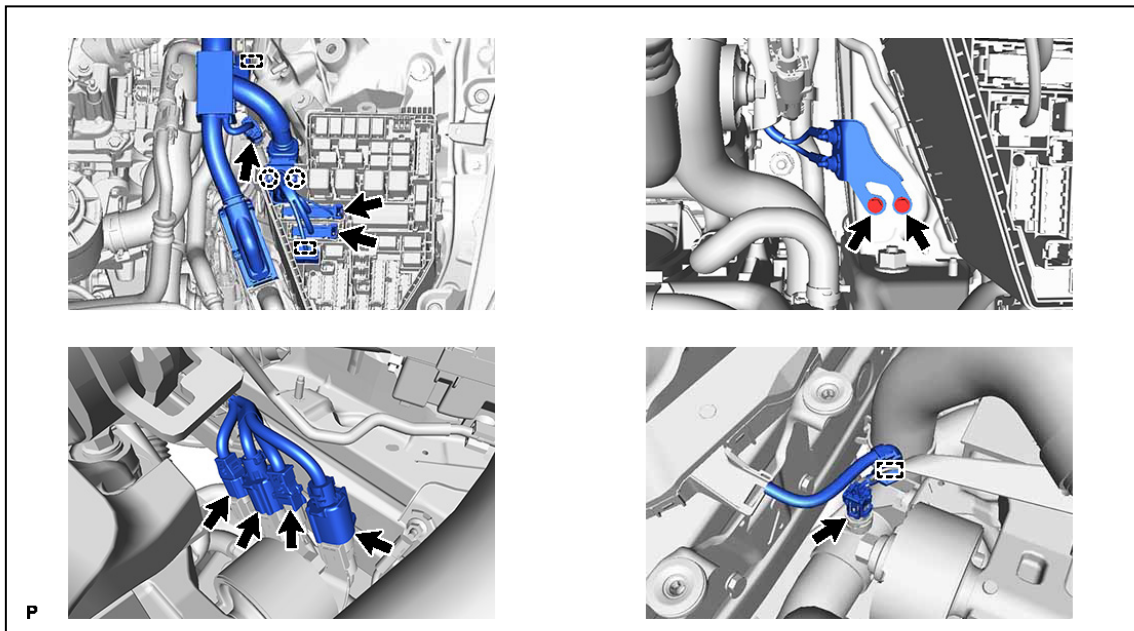

30. REMOVE NO. 1 BATTERY PACK WIRE



CAUTION:
Wear insulated gloves.

a.

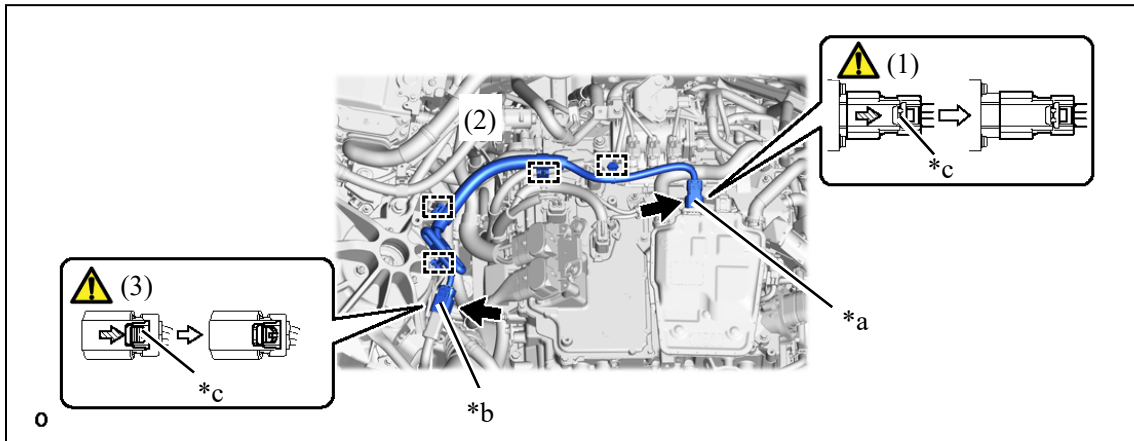

*a	Connector A	*b	Connector B
*c	Green-colored Lock	-	-
	Slide	-	-

- (1) Using a screwdriver, slide the green-colored lock of the connector A as shown in the illustration to release it and disconnect the No. 1 battery pack wire.
- (2) Disengage the clamp.
- (3) Using a screwdriver, slide the green-colored lock of the connector B as shown in the illustration to release it and disconnect the No. 1 battery pack wire.

31. REMOVE NO. 4 FC JUNCTION CABLE BRACKET

	CAUTION: Wear insulated gloves.
--	--

a.

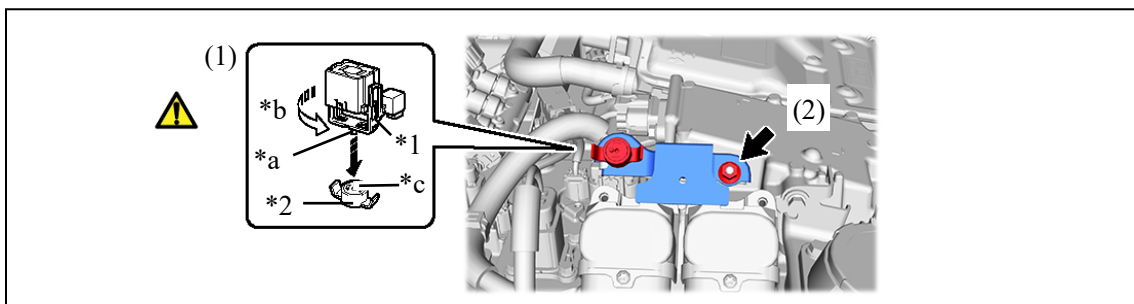

*1	Service Plug Grip	*2	Battery Cover Lock Striker
*a	Projection	*b	Turn
*c	Button	-	-

- (1) Using the service plug grip, remove the battery cover lock striker.

Hint:

Insert the projection of the service plug grip and turn the button of the battery cover lock striker counterclockwise to release the lock.

- (2) Remove the nut and No. 4 FC junction cable bracket.

32. DISCONNECT FLOOR UNDER WIRE



CAUTION:
Wear insulated gloves.

a.

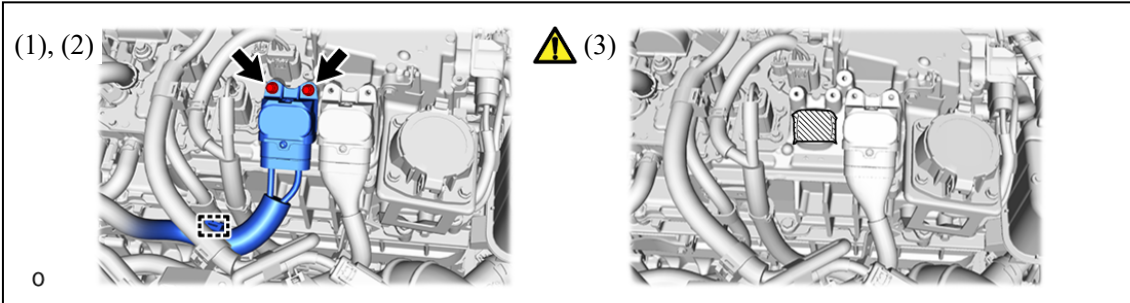

- (1) Disengage the clamp.
- (2) Remove the 2 bolts and disconnect the floor under wire from the FC stack assembly.
- (3) Protect the openings of the FC stack assembly with protective tape (non-residue type) to prevent the entry of foreign matter or water.

33. DISCONNECT FC JUNCTION CABLE



CAUTION:
Wear insulated gloves.

a.

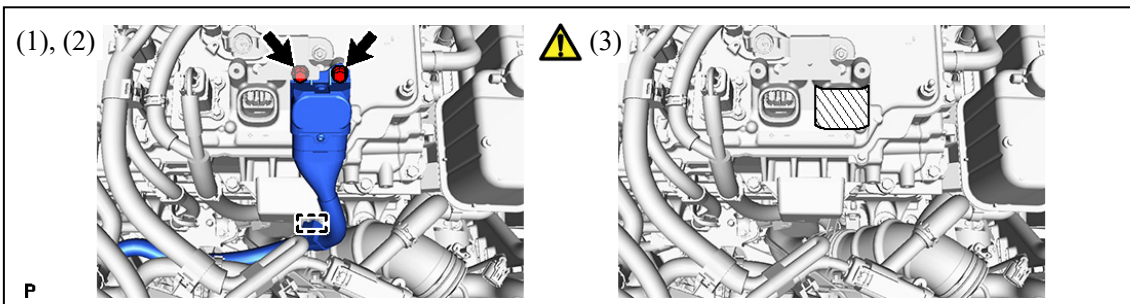

- (1) Detach the clamp.
- (2) Remove the 2 bolts and disconnect the FC junction cable from the FC converter assembly.
- (3) Protect the openings of the FC converter assembly with protective tape (non-residue type) to prevent the entry of foreign matter or water.

34. REMOVE EV RESERVE TANK ASSEMBLY

a.

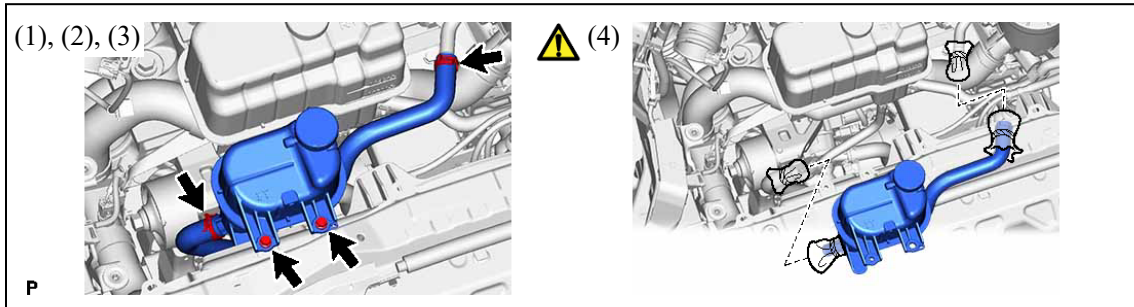

- (1) Slide the clip, disconnect the No. 6 FC inverter cooling hose from the No. 4 FC inverter cooling pipe.
- (2) Slide the clip, disconnect the No. 7 FC inverter cooling hose from the EV reserve tank assembly.
- (3) Remove the 2 bolts and EV reserve tank assembly.
- (4) Cover the connection of the EV reserve tank assembly, No. 6 FC inverter cooling hose, No. 7 FC inverter cooling hose and No. 4 FC inverter cooling pipe with plastic bags to prevent the foreign matter.

35. REMOVE FC RADIATOR RESERVE TANK ASSEMBLY

a.

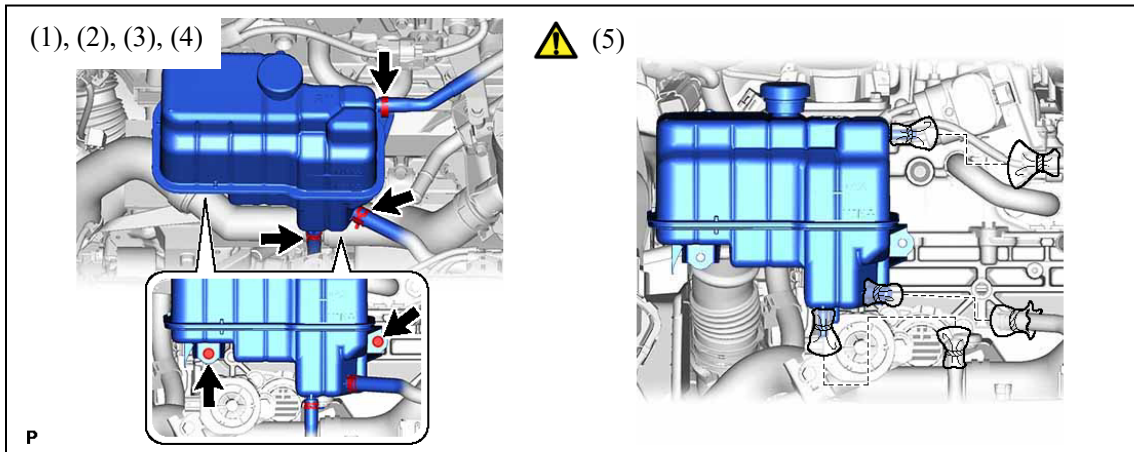

- (1) Slide the clip, disconnect the reserve tank inlet hose.
- (2) Slide the clip, disconnect the radiator to reserve tank hose.
- (3) Slide the clip, disconnect the reserve tank outlet hose.
- (4) Remove the 2 bolts and FC radiator reserve tank assembly.
- (5) Cover the connection of the FC radiator reserve tank assembly, reserve tank inlet hose, radiator to reserve tank hose and reserve tank outlet hose with plastic bags to prevent the foreign matter.

36. DISCONNECT NO. 9 FC RADIATOR HOSE

a.

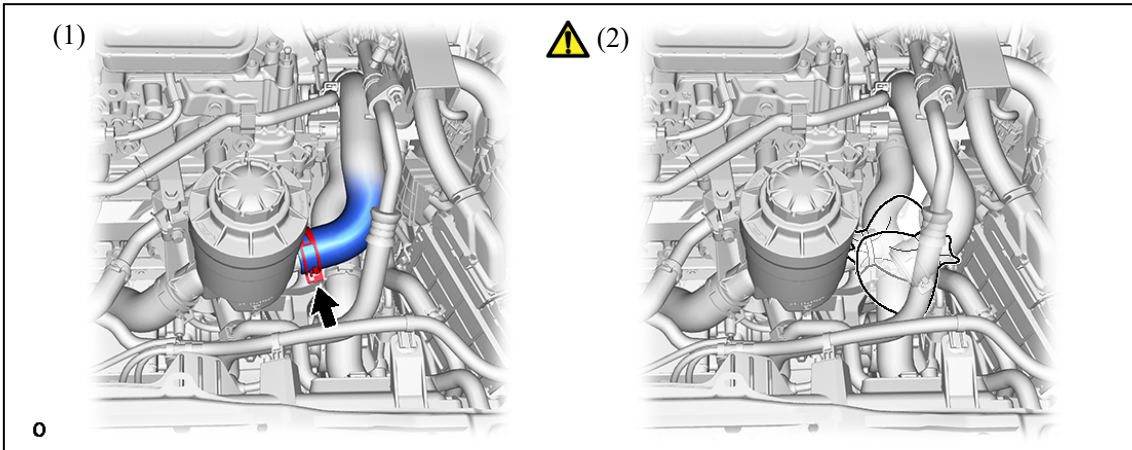

- (1) Slide the hose clip and disconnect the No. 9 FC radiator hose from the FC cooling ion water exchanger assembly.
- (2) To prevent contamination by foreign matter, cover the connecting portions of the No. 9 FC radiator hose and FC cooling ion water exchanger assembly with plastic bags.

37. DISCONNECT NO. 13 FC RADIATOR HOSE

a.

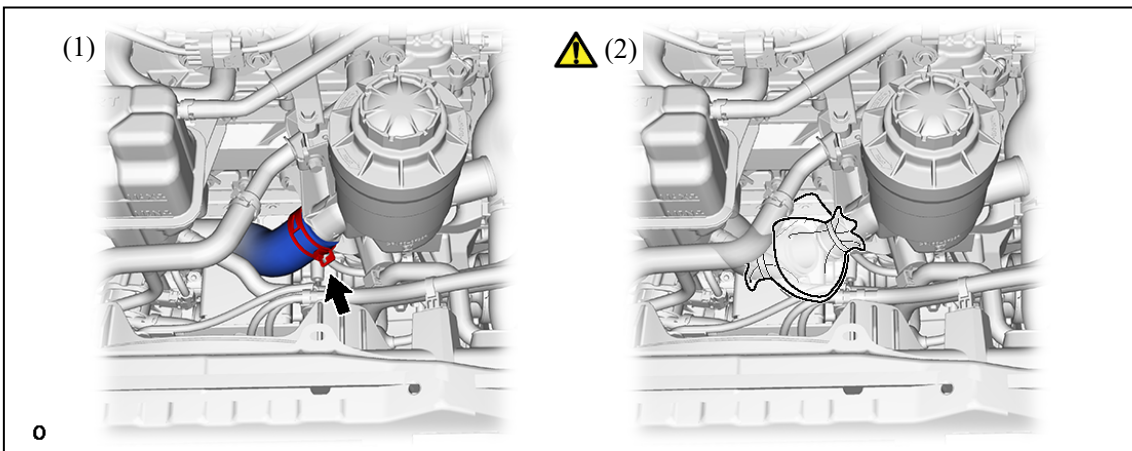

- (1) Slide the hose clip and disconnect the No. 13 FC radiator hose from the FC cooling ion water exchanger assembly.
- (2) To prevent contamination by foreign matter, cover the connecting portions of the No. 13 FC radiator hose and FC cooling ion water exchanger assembly with plastic bags.

38. DISCONNECT RADIATOR TO RESERVE TANK HOSE

a.

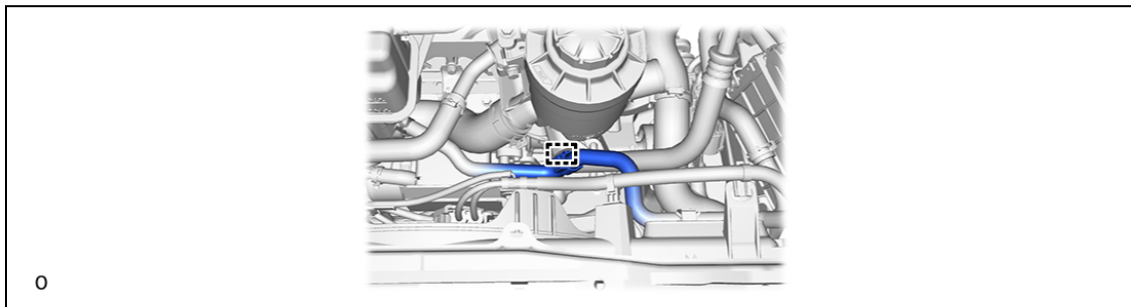

39. DISCONNECT NO. 4 FC INVERTER COOLING PIPE

a.

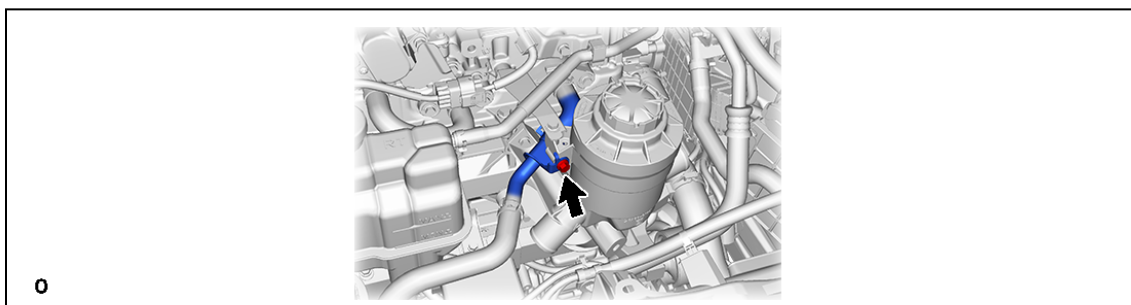

40. REMOVE FC COOLING WATER ION EXCHANGER BRACKET

a.

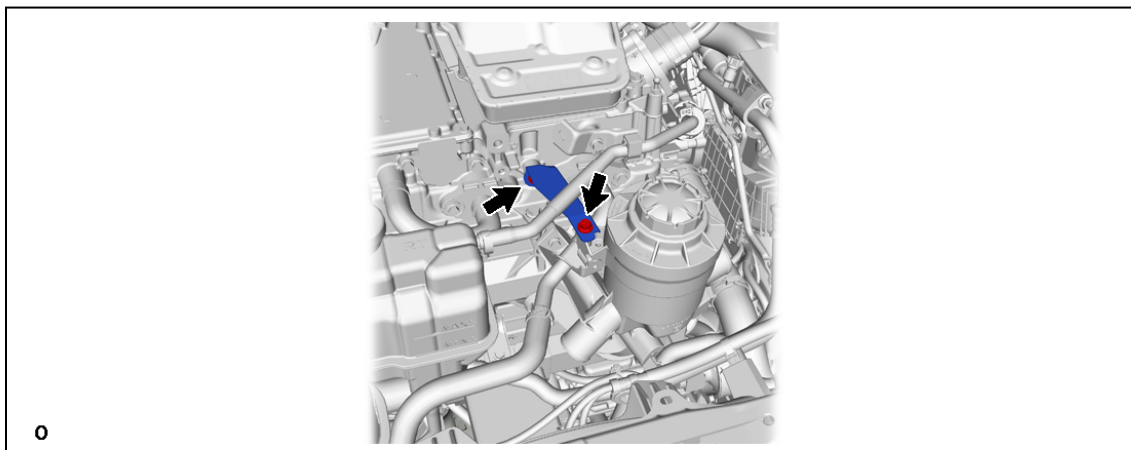

41. REMOVE FC COOLING WATER ION EXCHANGER ASSEMBLY

a.

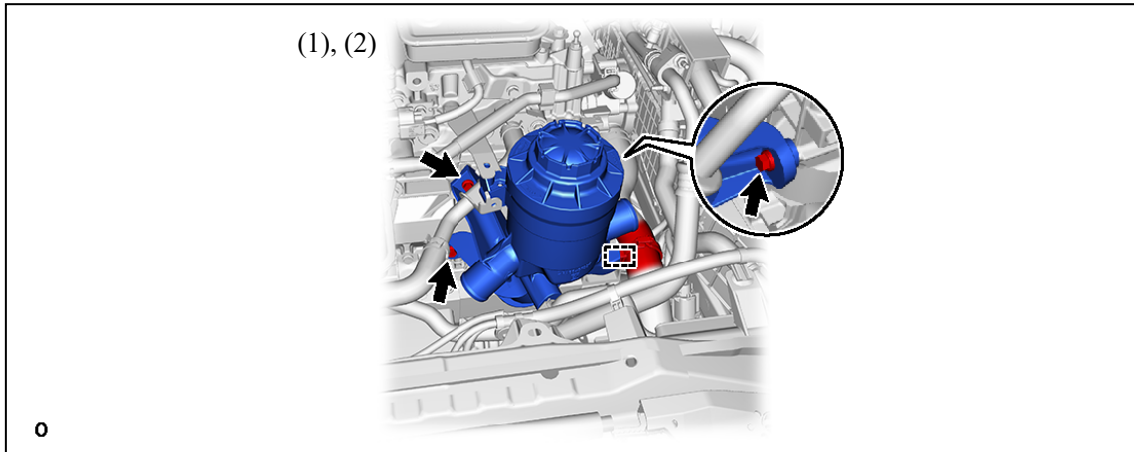

(1) Remove the 3 bolts.

(2) Detach the clamp and remove the FC cooling ion water exchanger assembly.

42. DISCONNECT NO. 15 FC INVERTER COOLING HOSE

a.

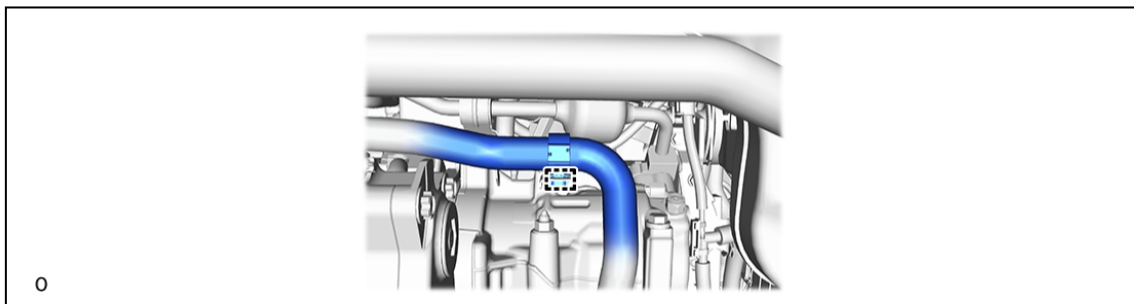

43. DISCONNECT NO. 1 DISCHARGE HOSE SUB-ASSEMBLY

a.

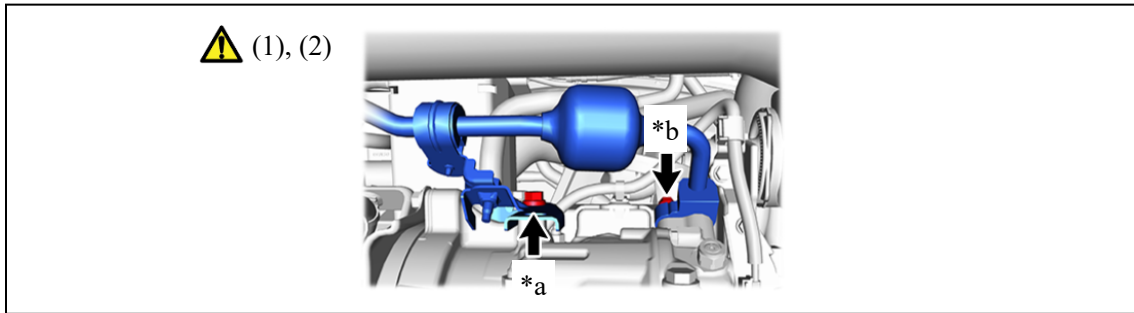

*a	Bolt (A)	*b	Bolt (B)
----	----------	----	----------

(1) Remove the bolt (A).

(2) Remove the bolt (B) and disconnect the No. 1 discharge hose sub-assembly.

Notice:

Seal the openings of the disconnected parts using vinyl tape to prevent moisture and foreign matter from entering them.

44. DISCONNECT SUCTION HOSE SUB-ASSEMBLY A

a.

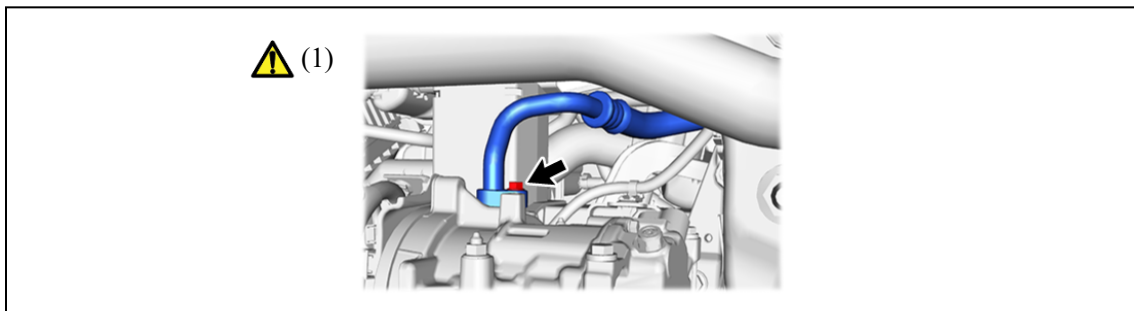

(1) Remove the bolt and disconnect the suction hose sub-assembly A.

Notice:

Seal the openings of the disconnected parts using vinyl tape to prevent moisture and foreign matter from entering them.

45. DISCONNECT NO. 1 FC RADIATOR HOSE

a.

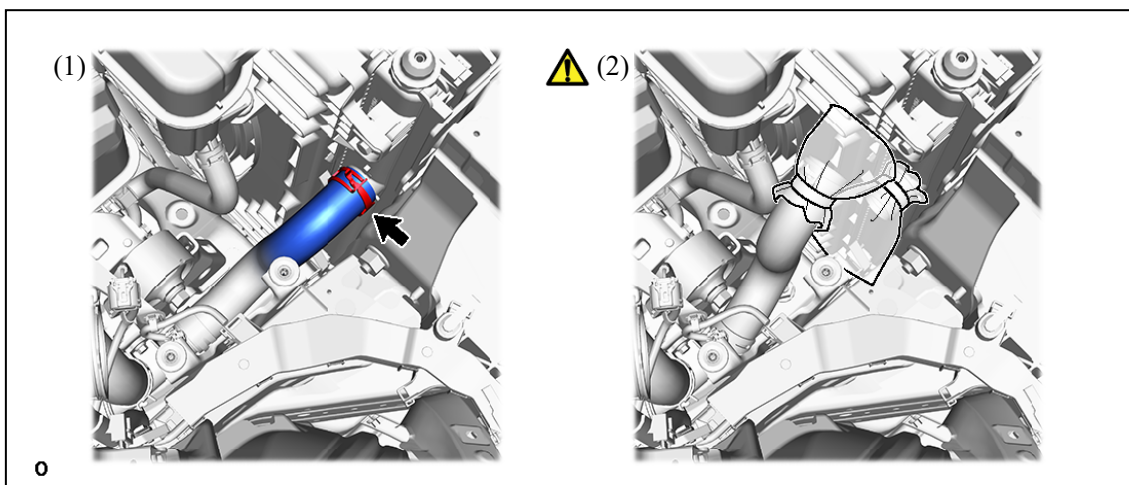

- (1) Slide the hose clip and disconnect the No. 1 FC radiator hose from the FC radiator assembly.
- (2) To prevent contamination by foreign matter, cover the connecting portions of the No. 1 FC radiator hose and FC radiator assembly with plastic bags.

46. REMOVE NO. 7 FC RADIATOR HOSE

a.

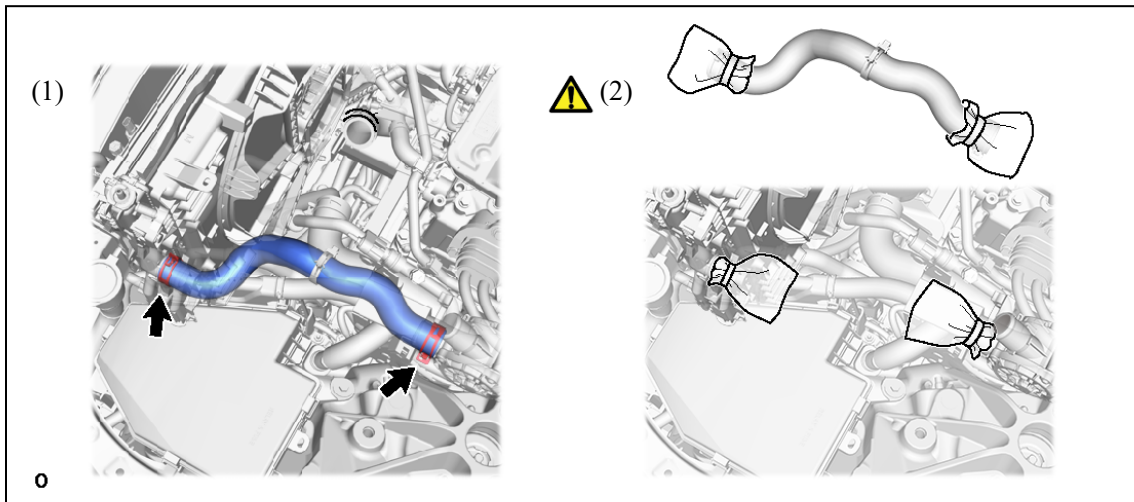

- (1) Slide the 2 hose clips and remove the No. 7 FC radiator hose from the FC cooling water temperature control valve and FC radiator assembly.
- (2) To prevent contamination by foreign matter, cover the connecting portions of the No. 7 FC radiator hose, FC cooling water temperature control valve and FC radiator assembly with plastic bags.

47. DISCONNECT NO. 13 FC INVERTER COOLING HOSE

a.

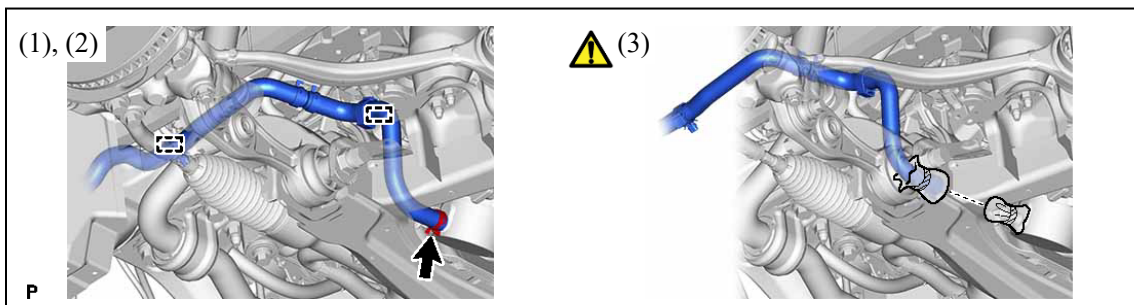

- (1) Detach the 2 clamps.
- (2) Slide the clip, disconnect the No. 13 FC inverter cooling hose.
- (3) Cover the connection of the No. 13 FC inverter cooling hose and FC air compressor with motor assembly with plastic bags to prevent the foreign matter.

48. DISCONNECT NO. 1 FC INVERTER COOLING HOSE SUB-ASSEMBLY

a.

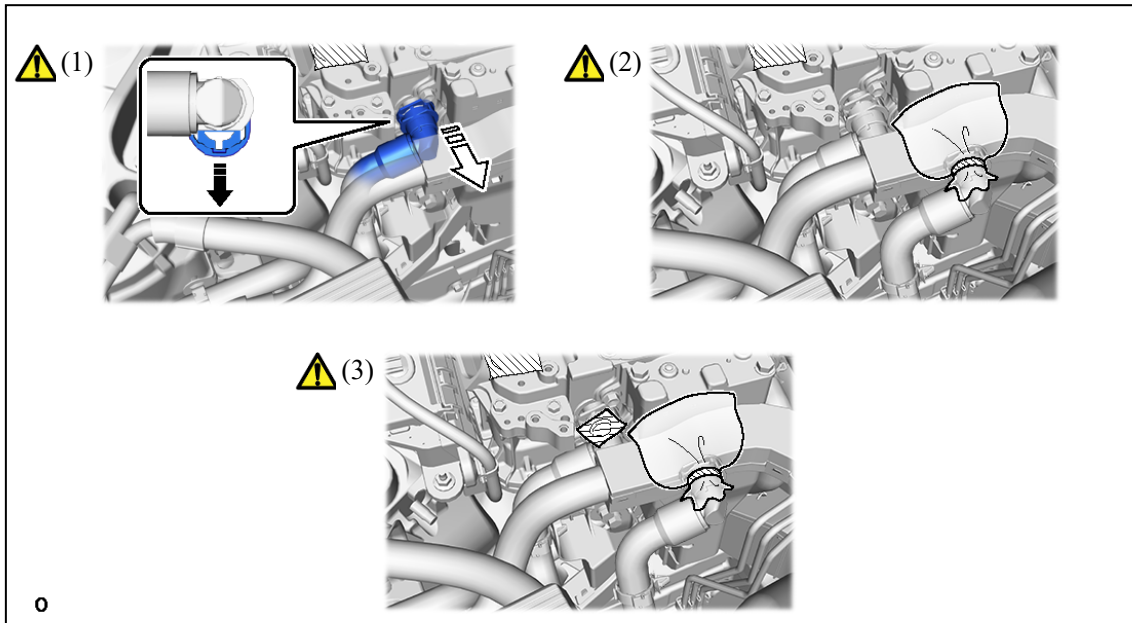

- (1) Release the retainer and disconnect the No. 1 FC inverter cooling hose sub-assembly from the inverter with converter assembly as shown in the illustration.
- (2) Protect the connecting part of the No. 1 FC inverter cooling hose sub-assembly with a plastic bag to prevent entry of foreign matter.
- (3) Protect the openings of the inverter with converter assembly with protective tape (non-residue type) to prevent the entry of foreign matter or water.

Notice:

Apply insulating tape to the pipes and in the disconnected hoses, or cover the pipes and hoses with plastic bags to prevent foreign matter from entering the cooling system and to prevent coolant from spilling near the inverter with converter assembly.

49. DISCONNECT WATER HOSE SUB-ASSEMBLY C

a.

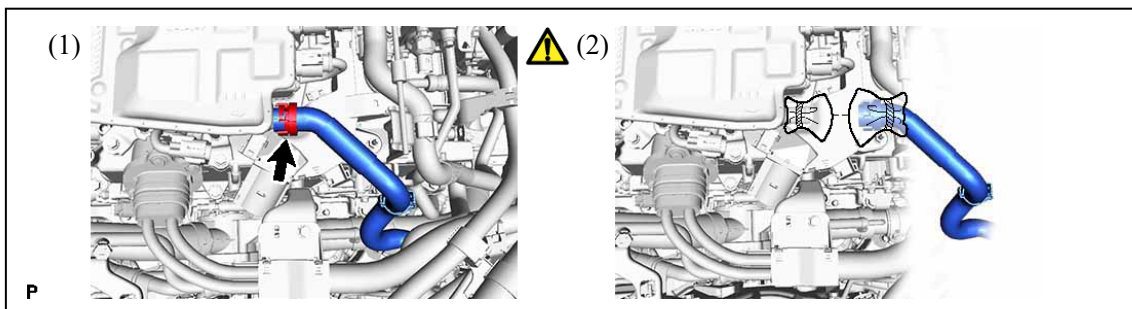

- (1) Slide the clip, disconnect the water hose sub-assembly C.
- (2) Cover the connection of the water hose sub-assembly C and electric heater sub-assembly with plastic bags to prevent the foreign matter.

50. DISCONNECT WATER HOSE SUB-ASSEMBLY E

a.

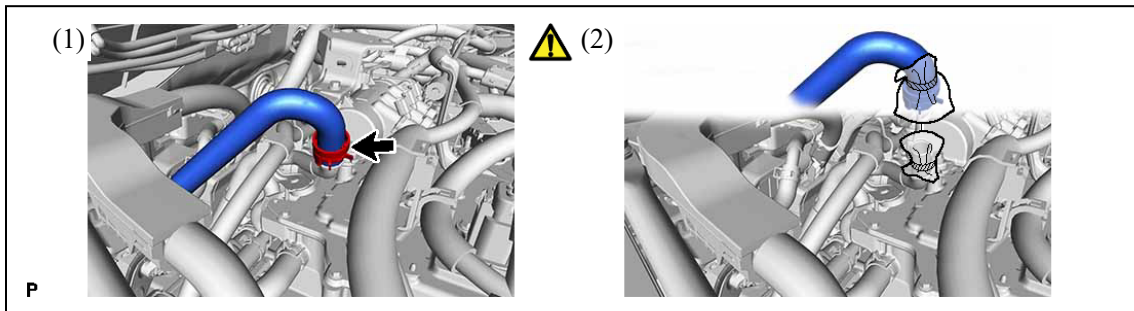

- (1) Slide the clip, disconnect the water hose sub-assembly E.
- (2) Cover the connection of the water hose sub-assembly E and water hose sub-assembly D with plastic bags to prevent the foreign matter.

51. REMOVE FRONT BUMPER ASSEMBLY

a.

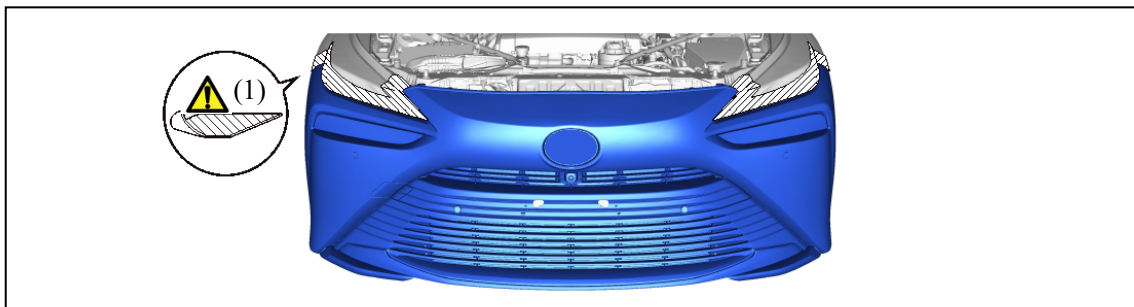

- (1) Put protective tape around the front bumper assembly.

b.

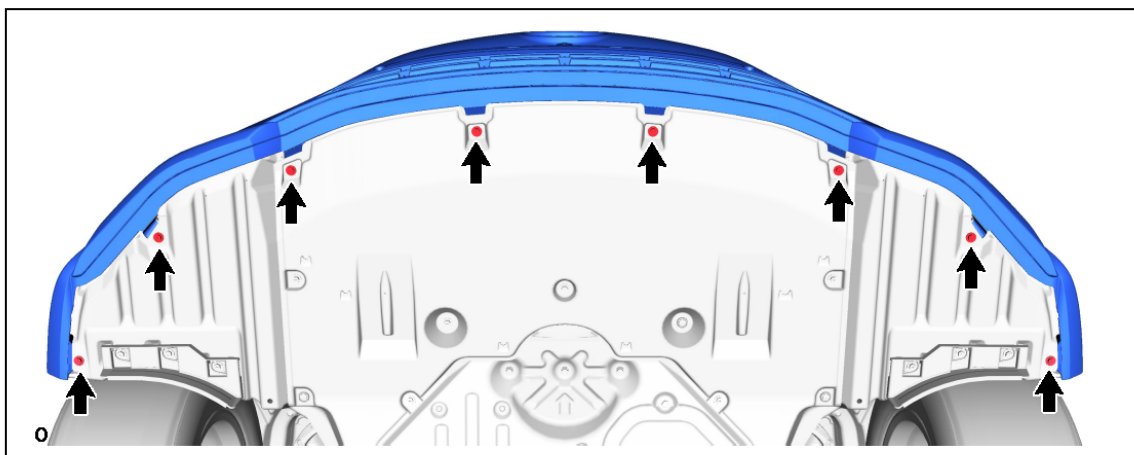

- (1) Remove the 8 screws.

c.

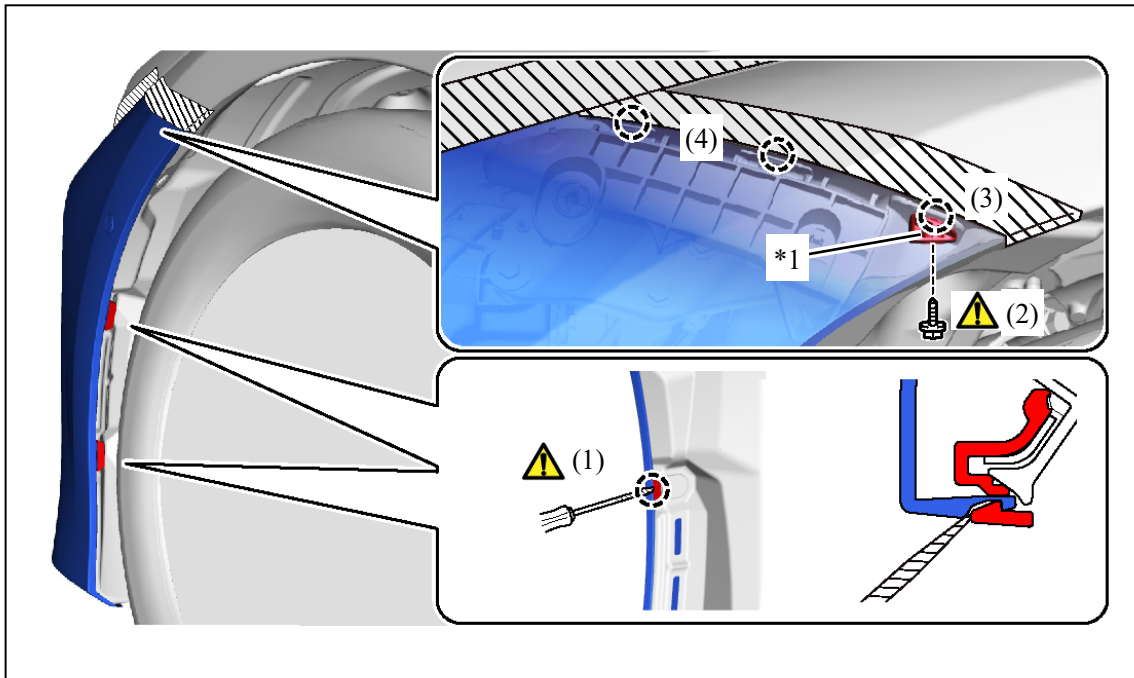

*1	Front Bumper Side Mounting Bracket LH	-	-
----	---------------------------------------	---	---

- (1) Using a screwdriver, detach the claw as shown in the illustration.
- (2) Fold back the front fender splash shield sub-assembly LH and remove the screw.
- (3) Detach the claw and remove the front bumper side mounting bracket LH.
- (4) Detach the claw.

d. Use the same procedure for the other side.

e.

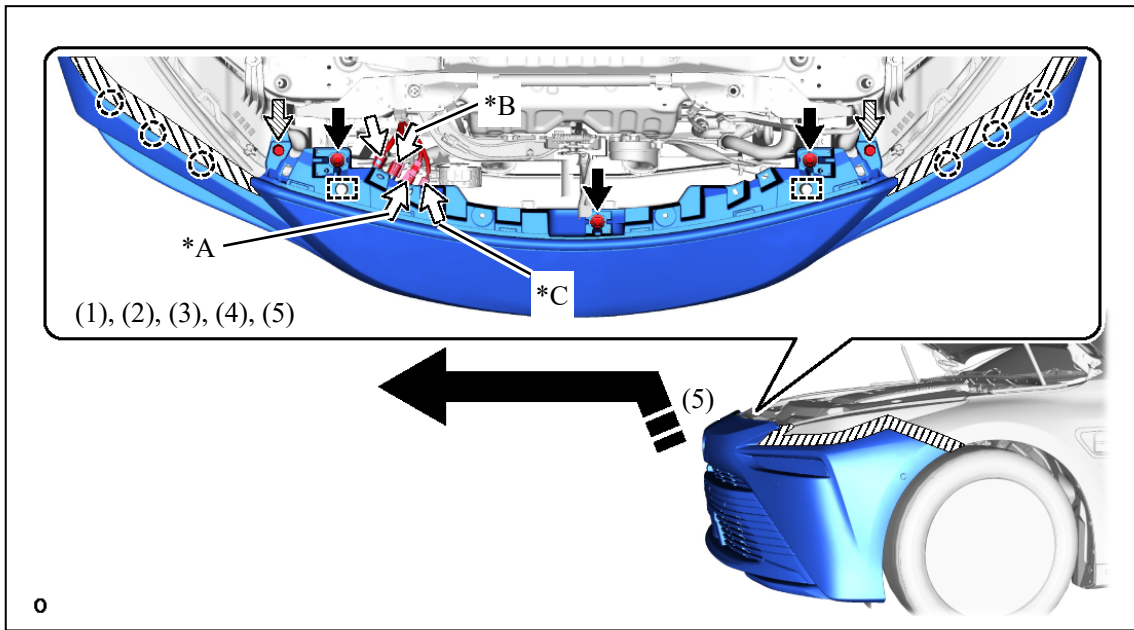

*A	w/ Advanced Drive	*B	w/ Advanced Park
*C	w/ Panoramic View Monitor System	-	-
	Remove in this Direction		Bolt
	Connector		Clip

- (1) Disconnect each connector.
- (2) Remove the 3 bolts.
- (3) Remove the 2 clips.
- (4) Detach the claw.
- (5) Detach the guide and remove the front bumper assembly as shown in the illustration.

52. REMOVE NO. 2 FRONT BUMPER REINFORCEMENT SUB-ASSEMBLY

a.

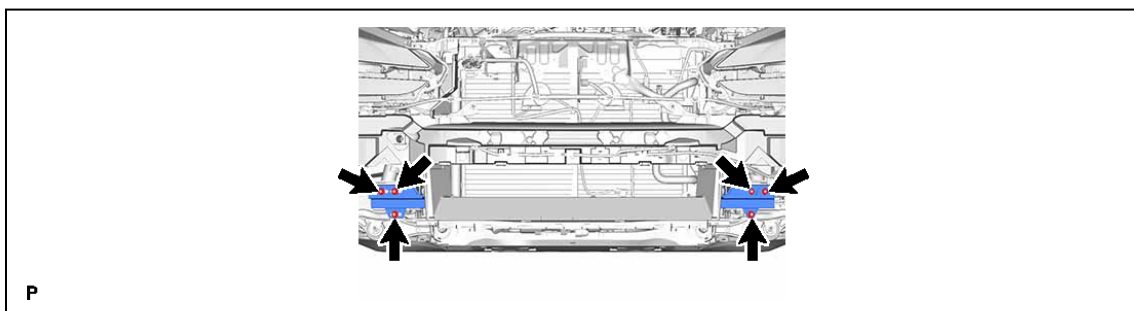

53. REMOVE RADIATOR SUPPORT EXTENSION LH

a.

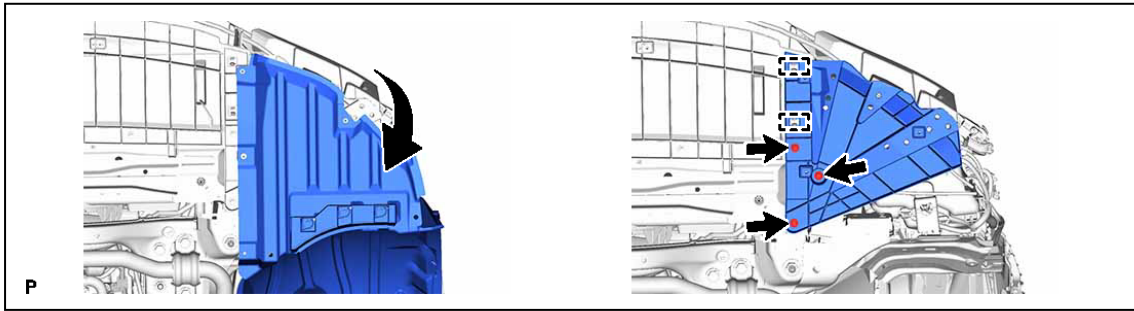

54. REMOVE RADIATOR SUPPORT EXTENSION RH

a.

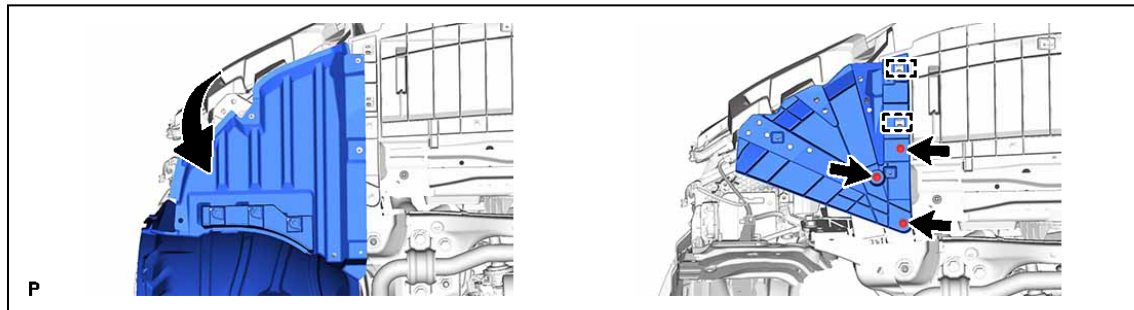

55. REMOVE REAR FRAME SIDE RAIL LH

a.

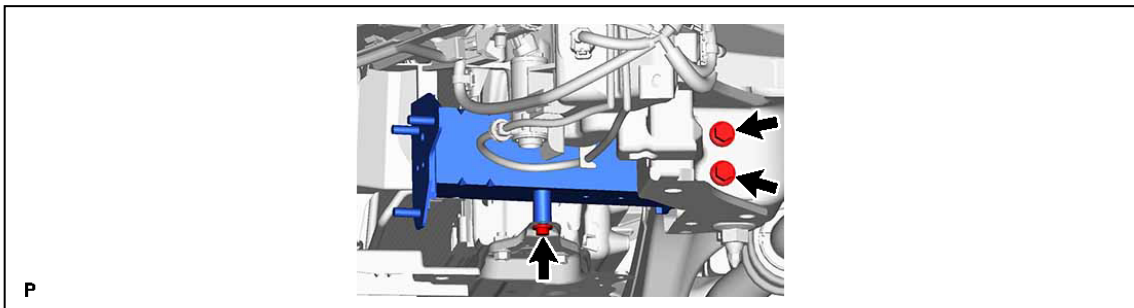

56. REMOVE REAR FRAME SIDE RAIL RH

a.

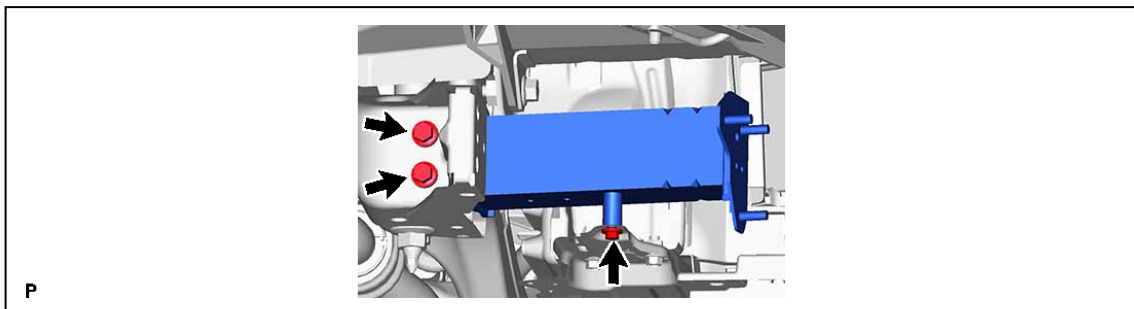

57. REMOVE FRONT WHEEL ASSEMBLY

a.

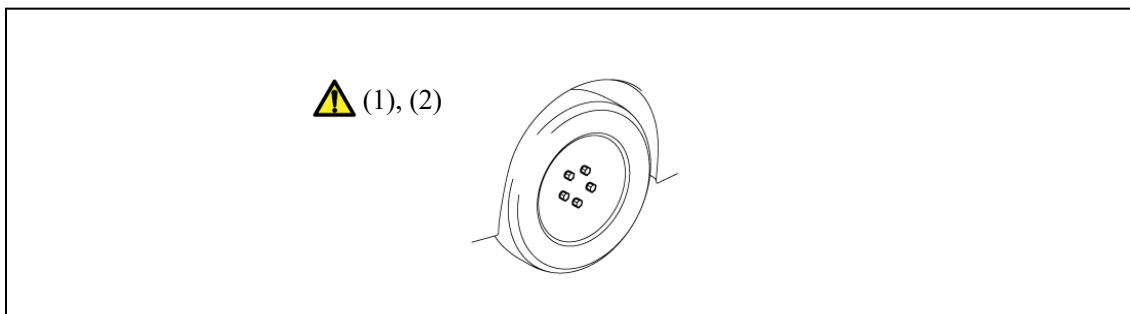

(1) Loosen the axle hub nuts approximately 90°.

(2) Lift up the vehicle and remove the axle hub nuts and front wheel assembly.

58. DISCONNECT FRONT SKID CONTROL SENSOR WIRE LH

a.

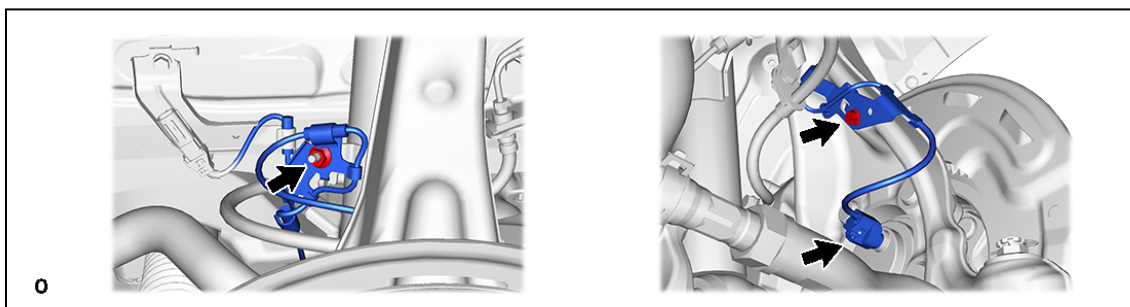

59. DISCONNECT DISC BRAKE CYLINDER ASSEMBLY LH

a.

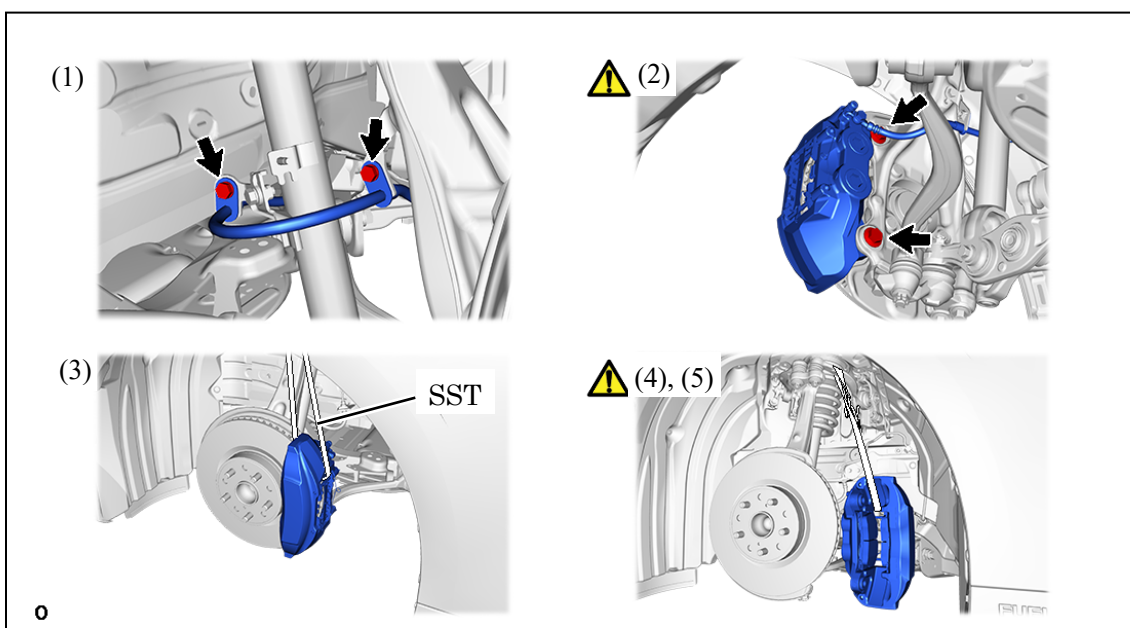

(1) Remove the 2 bolts and disconnect the No. 2 front flexible hose from the front flexible hose bracket LH and No. 2 front flexible hose bracket LH.

- (2) Loosen the bolts on the lower side of the disc brake cylinder assembly LH and remove the bolts on the top side.

Notice:

Do not excessively loosen the bolts on the lower side of the disc brake cylinder assembly LH.

- (3) Tilt the disc brake cylinder assembly LH and install SST as shown in the illustration.

SST

09727-00110

- (4) Install SST to the front upper No. 2 suspension arm assembly LH.
(5) Remove the bolt on the lower side of the disc brake cylinder assembly LH and disconnect it.

Notice:

- Do not apply excessive force to the flexible hose.
- If there is no looseness in the flexible hose, adjust the length of SST.

60. REMOVE FRONT DISC LH

a.

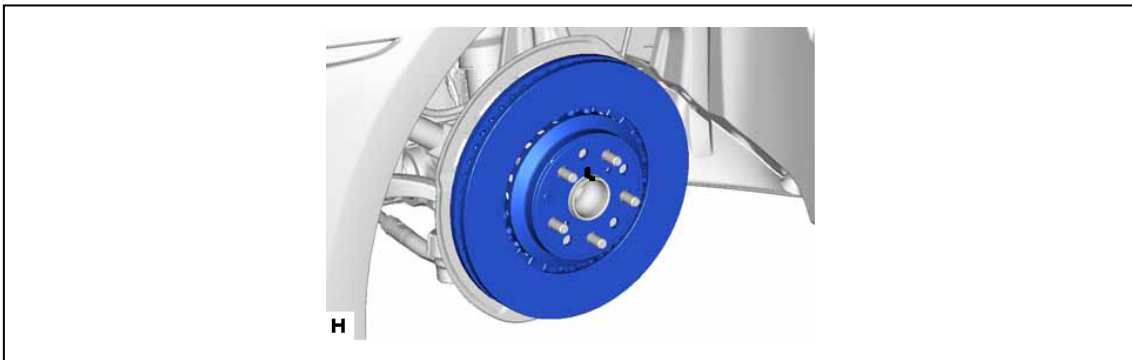

61. REMOVE FRONT DISC BRAKE DUST COVER LH

a.

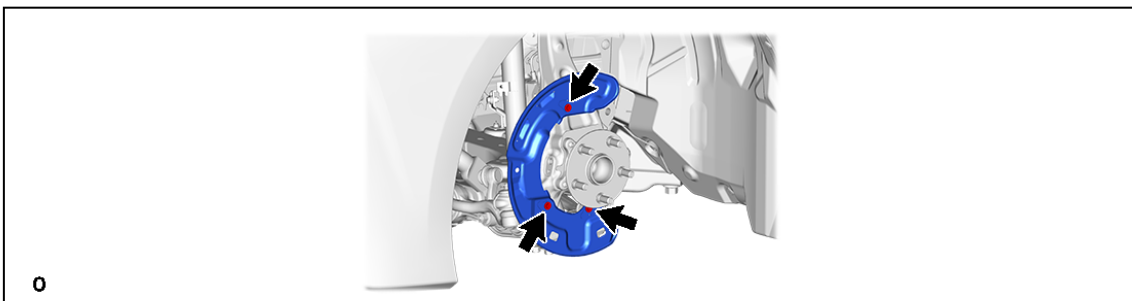

62. DISCONNECT STEERING KNUCKLE LH

a.

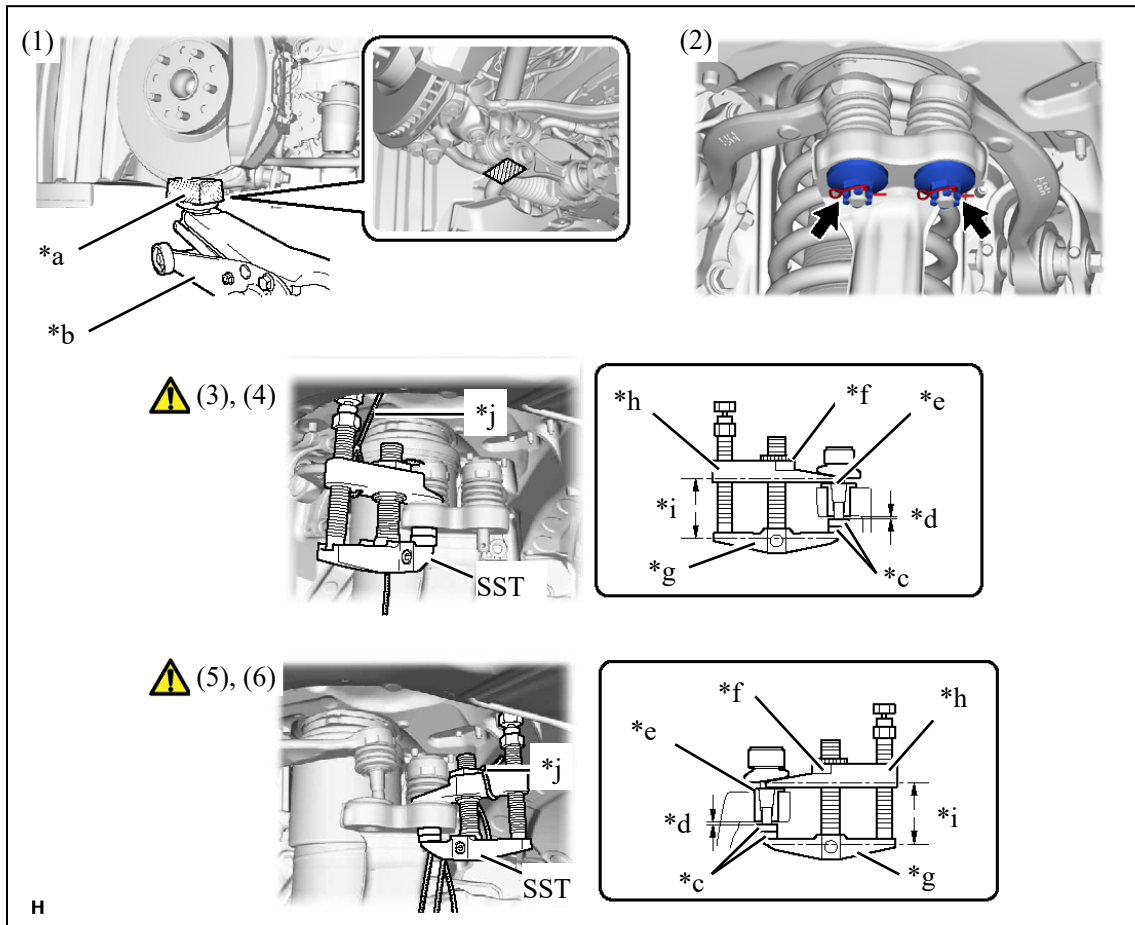

*a	Wooden Block	*b	Jack
*c	SST (Spacer B)	*d	1 mm (0.0394 in.)
*e	Spacer	*f	Center Nut
*g	Body	*h	Claw
*i	Parallel	*j	String

- (1) Support the front suspension lower arm assembly LH using a jack and wooden block.
- (2) Remove the 2 clips and 2 nuts.
- (3) Install 2 SST (spacer B) onto the front upper No. 1 suspension arm assembly LH so that there is a space of approximately 1 mm (0.0394 in.) between the arm and spacers.

SST

09960-20010 (09961-02060)

Notice:

- Make sure to install the spacers (SST spacer B) as the steering knuckle spacer may shift.
- As SST may become damaged, make sure the space between the arm and spacers is not 1 mm (0.0394 in.) or less.

- (4) Using SST, disconnect the steering knuckle assembly LH from the front upper No. 1 suspension arm assembly LH.

SST

09960-20010 (09961-02010)

Notice:

- Apply molybdenum grease to the bolt threads and end of the SST bolt.
- Make sure to tie the string of SST to the vehicle to prevent SST from dropping.

- (5) Install 2 SST (spacer B) onto the front upper No. 2 suspension arm assembly LH so that there is a space of approximately 1 mm (0.0394 in.) between the arm and spacers.

SST

09960-20010 (09961-02060)

Notice:

- Make sure to install the spacers (SST spacer B) as the steering knuckle spacer may shift.
- As SST may become damaged, make sure the space between the arm and spacers is not 1 mm (0.0394 in.) or less.

- (6) Using SST, disconnect the steering knuckle assembly LH from the front upper No. 2 suspension arm assembly LH.

SST

09960-20010 (09961-02010)

Notice:

- Apply molybdenum grease to the bolt threads and end of the SST bolt.
- Make sure to tie the string of SST to the vehicle to prevent SST from dropping.

63. DISCONNECT TIE ROD ASSEMBLY LH

a.

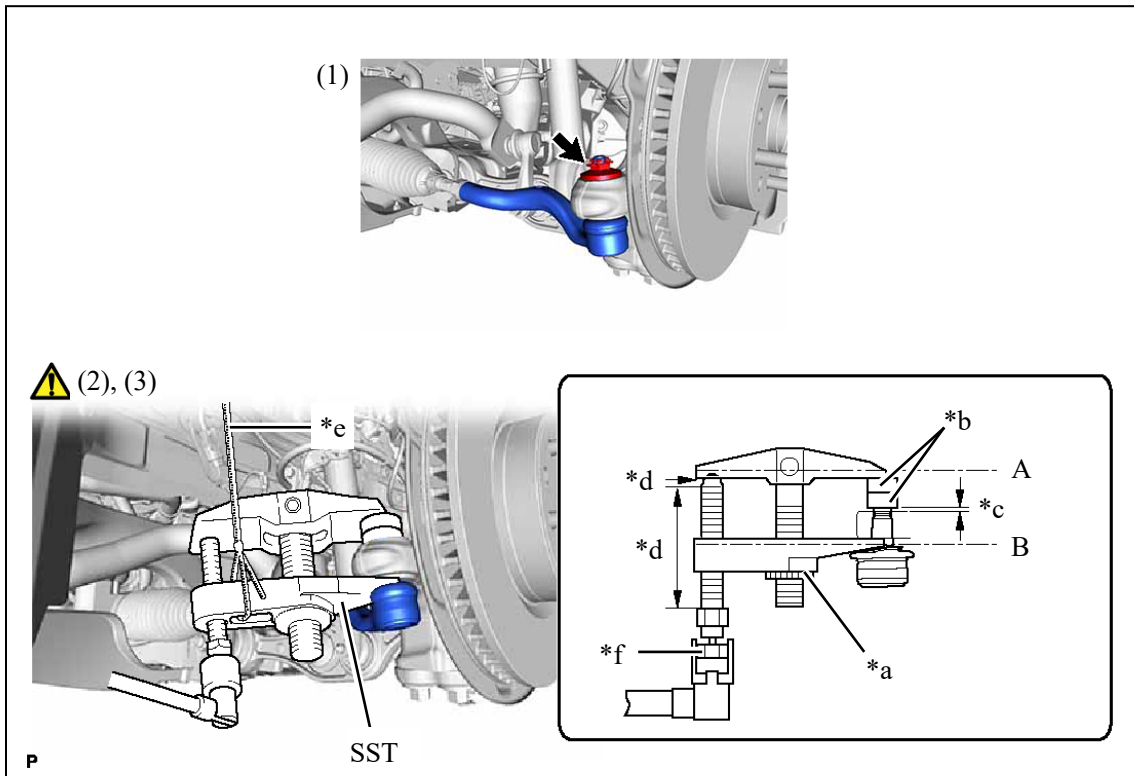

*a	Center Nut	*b	SST (Spacer B)
*c	1 mm (0.0394 in.)	*d	Molybdenum grease application area
*e	String	*f	Place wrench here

(1) Remove the clip and nut.

(2) Install 2 spacers (SST spacer B) to the steering knuckle LH as shown in the illustration.

SST

09960-20010 (09961-02060)

Notice:

Make sure that the clearance between the tie rod assembly LH and spacers (SST spacer B) is 1 mm (0.0394 in.) or more to prevent damage to SST.

(3) Using SST, disconnect the tie rod assembly LH from steering knuckle LH.

SST

09960-20010 (09961-02010)

Caution:

Apply molybdenum grease to the bolt threads and the tip of SST.

Notice:

- Be sure to tighten the string firmly to secure SST to the steering knuckle to prevent SST from falling off.
- Install SST so that (A) and (B) shown in the illustration are parallel.
- Be sure to place the wrench on the part shown in the illustration.

64. LOOSEN FRONT LOWER SUSPENSION ARM ASSEMBLY LH

a.

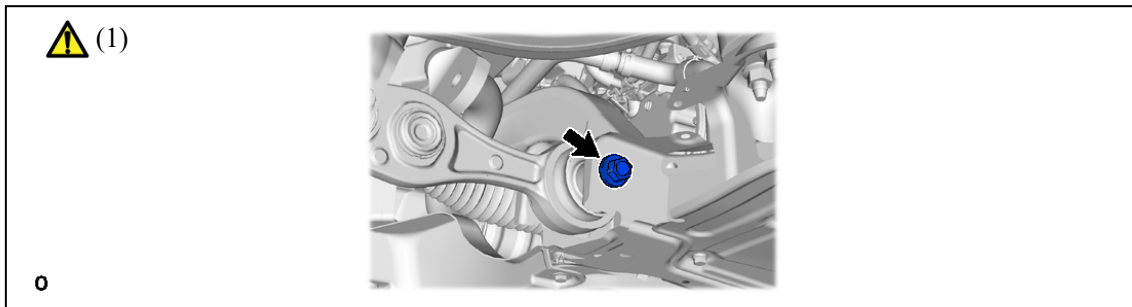

(1) Loosen the installation bolt of the front suspension lower arm assembly LH.

Hint:

Only loosen the bolt. There is no need to remove it.

65. REMOVE FRONT STABILIZER LINK ASSEMBLY LH

a.

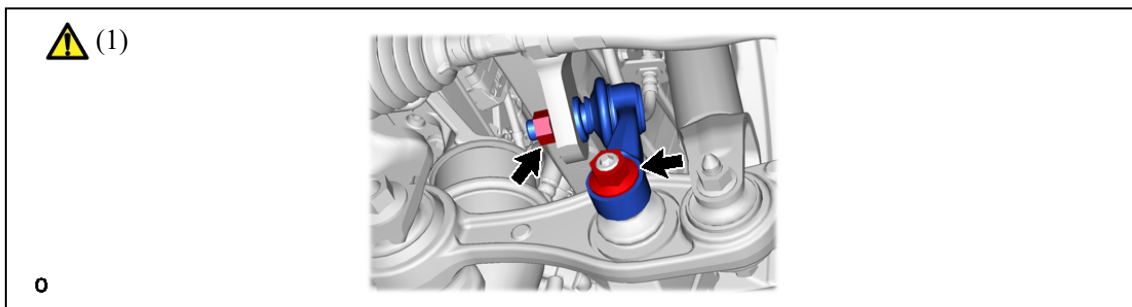

(1) Remove the 2 nuts and front stabilizer link assembly LH.

Hint:

If the ball joint turns together with the nut, use a 8 mm hexagon wrench to hold the stud bolt.

66. DISCONNECT FRONT SHOCK ABSORBER ASSEMBLY LH

a.

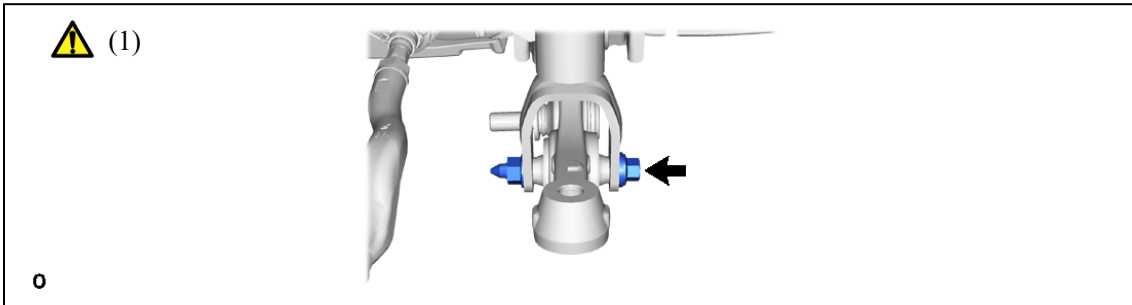

(1) Remove the bolt and nut, and separate the front shock absorber assembly LH from the lower suspension arm assembly LH.

Notice:

Because the nut has its own stopper, do not turn the nut. Loosen the bolt with the nut secured.

67. REMOVE STEERING KNUCKLE LH

a.

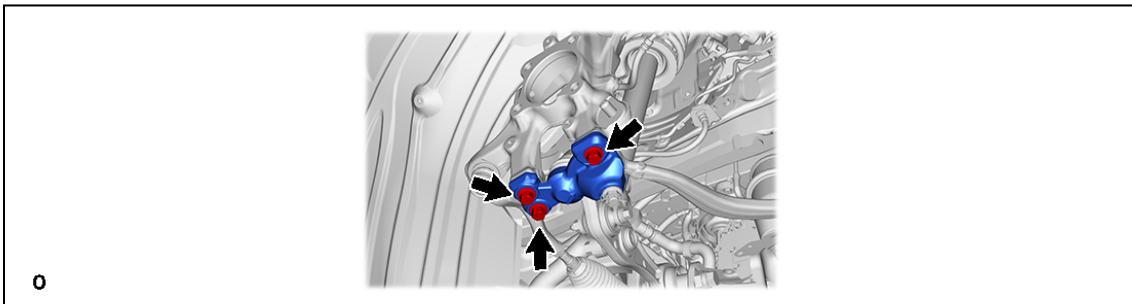

68. DISCONNECT FRONT SKID CONTROL SENSOR WIRE RH

a. Perform the same procedure as for the LH side.

69. DISCONNECT DISC BRAKE CYLINDER ASSEMBLY RH

a. Perform the same procedure as for the LH side.

70. REMOVE FRONT DISC RH

a. Perform the same procedure as for the LH side.

71. REMOVE FRONT DISC BRAKE DUST COVER RH

a. Perform the same procedure as for the LH side.

72. DISCONNECT STEERING KNUCKLE RH

- a. Perform the same procedure as for the LH side.

73. DISCONNECT TIE ROD ASSEMBLY RH

- a. Perform the same procedure as for the LH side.

74. LOOSEN FRONT LOWER SUSPENSION ARM ASSEMBLY RH

- a. Perform the same procedure as for the LH side.

75. REMOVE FRONT STABILIZER LINK ASSEMBLY RH

- a. Perform the same procedure as for the LH side.

76. DISCONNECT FRONT SHOCK ABSORBER ASSEMBLY RH

- a. Perform the same procedure as for the LH side.

77. REMOVE STEERING KNUCKLE RH

- a. Perform the same procedure as for the LH side.

78. DISCONNECT NO. 2 STEERING INTERMEDIATE SHAFT ASSEMBLY

- a.

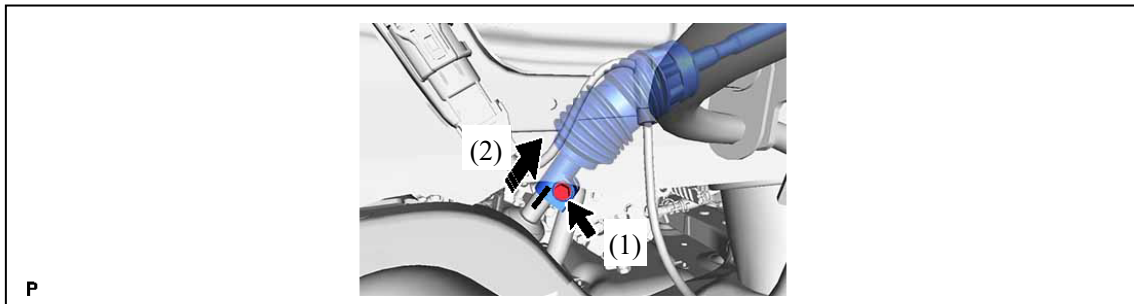

	Slide	-	-
---	-------	---	---

- (1) Remove the bolt.
- (2) Disconnect the No. 2 steering intermediate shaft assembly from the rack and pinion power steering gear assembly.

79. REMOVE FRONT COMPARTMENT SIDE COVER LH

a.

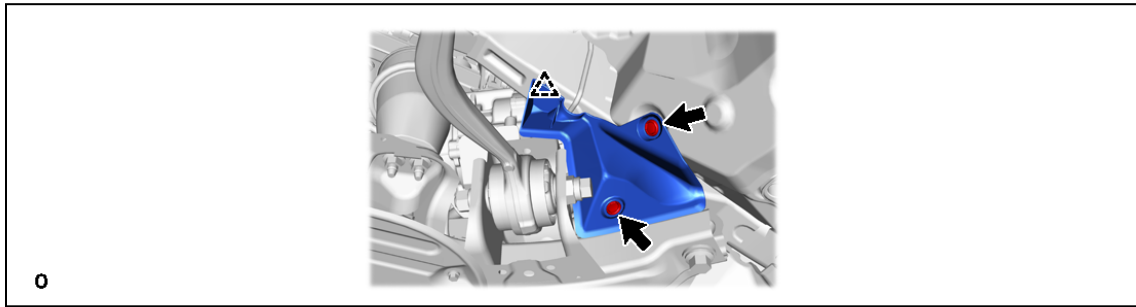

80. REMOVE FRONT COMPARTMENT SIDE COVER RH

a. Perform the same procedure as for the LH side.

81. REMOVE NO. 1 FC EXHAUST PIPE

a.

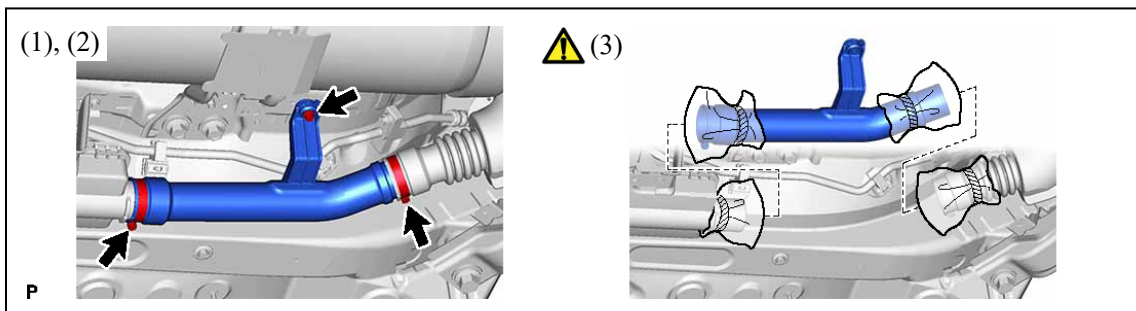



- (1) Loosen the 2 hose clamps.
- (2) Remove the bolt and No. 1 FC exhaust pipe.
- (3) Cover the connection of the No. 1 FC exhaust pipe and FC stack air outlet hose with plastic bags to prevent the foreign matter.

82. REMOVE FC CONVERTER WITH FC STACK ASSEMBLY WITH FRONT FRAME ASSEMBLY

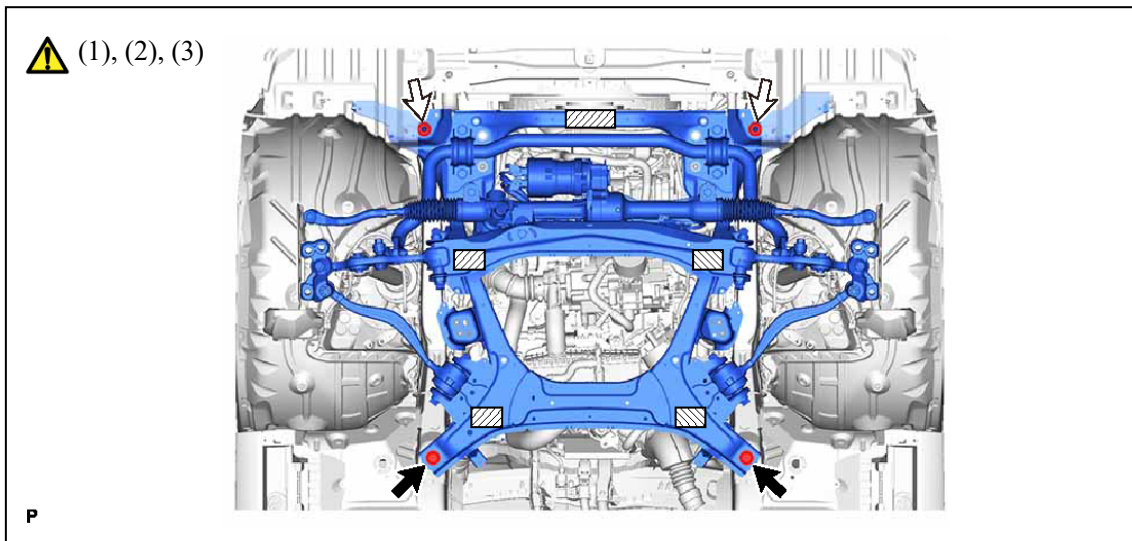
a.



	Bolt		Nut
	Attachments	-	-

(1) Set the FC converter with FC stack assembly with front frame assembly on an engine lifter.

Caution:

- The FC converter with FC stack assembly with front frame assembly is a heavy component. Make sure that it is supported securely.
- If it is not supported securely, it could fall and result in a serious accident.



Notice:

Place wooden blocks or plate lift attachments so that the FC converter with FC stack assembly with front frame assembly is level.

(2) Remove the 2 bolts and 2 nuts.

- (3) Operate the engine lifter, then slowly remove the FC converter with FC stack assembly with front frame assembly from the vehicle.

Notice:

- Perform this procedure with several people supporting the FC converter with FC stack assembly with front frame assembly so that it does not tilt or fall.
- Remove while paying attention to the wire harnesses and steering shaft.

83. REMOVE AIR CLEANER HOSE ASSEMBLY

a.

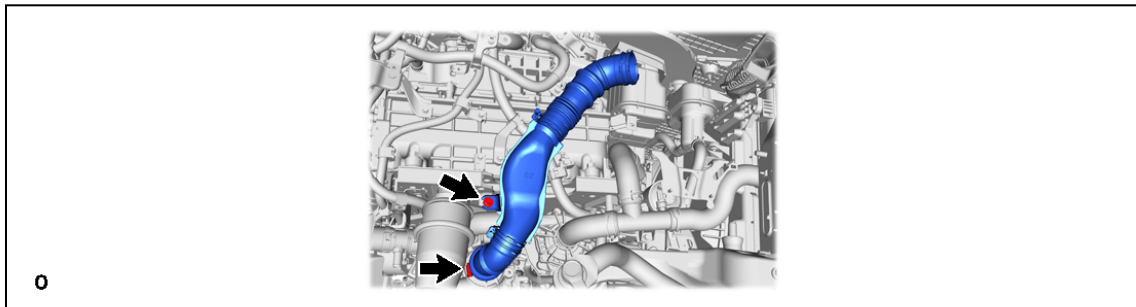

b.

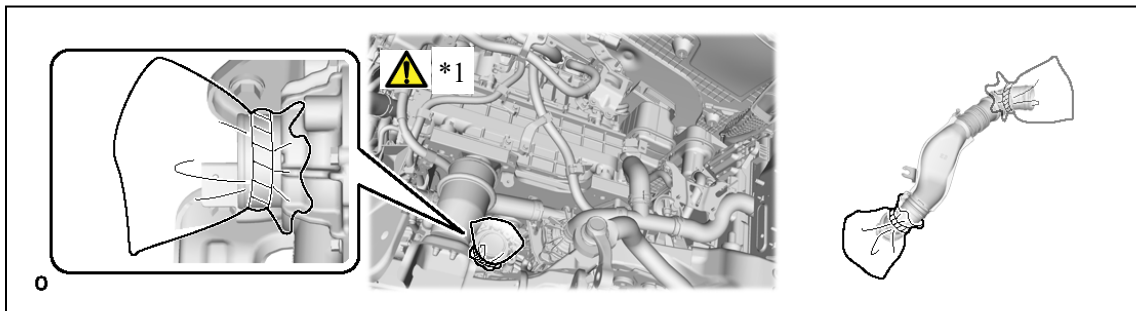

- (1) To prevent contamination by foreign matter or water droplets, cover the connecting portions of the air cleaner hose assembly and FC air compressor with motor assembly with plastic bags.

84. REMOVE WIRE HARNESS CLAMP BRACKET

a.

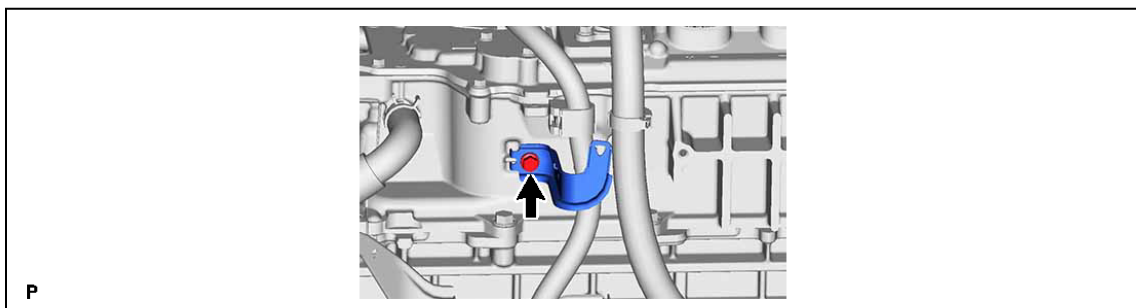

85. DISCONNECT FC COOLING WATER PUMP CABLE

a.

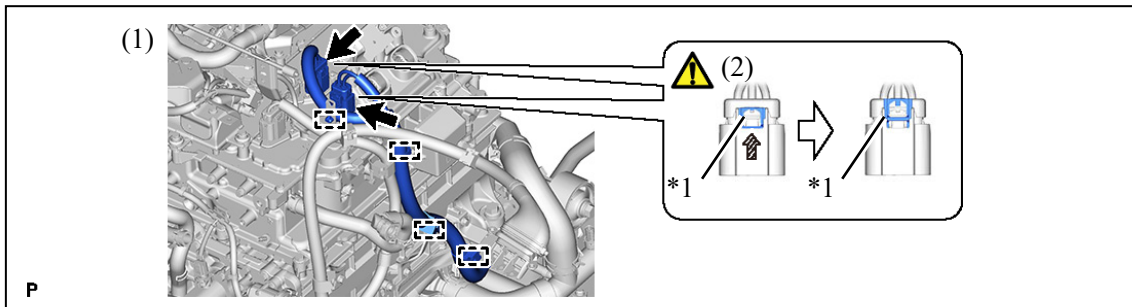

*1	Green-colored Lock	-	-
----	--------------------	---	---

(1) Detach the 4 clamps.

(2) As shown in the illustration, pull out the green lock of the connector and disconnect the 2 connectors.

86. DISCONNECT HYDROGEN RECIRCULATION PUMP CABLE

a.

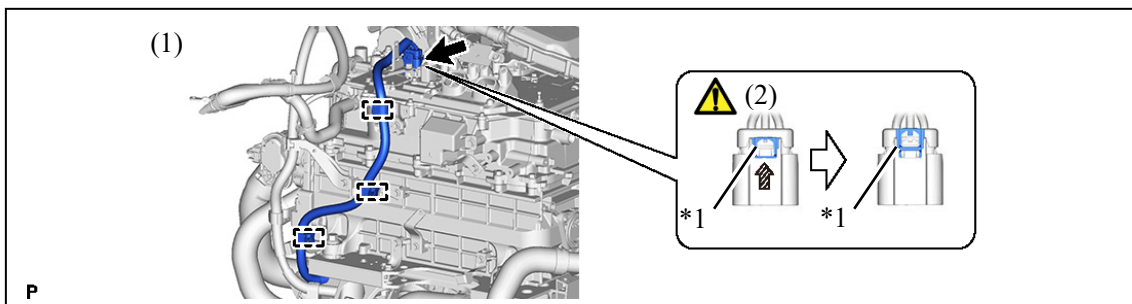

*1	Green-colored Lock	-	-
----	--------------------	---	---

(1) Detach the 3 clamps.

(2) As shown in the illustration, pull out the green lock of the connector and disconnect the connector.

87. DISCONNECT FC AIR COMPRESSOR MOTOR CABLE ASSEMBLY

a.

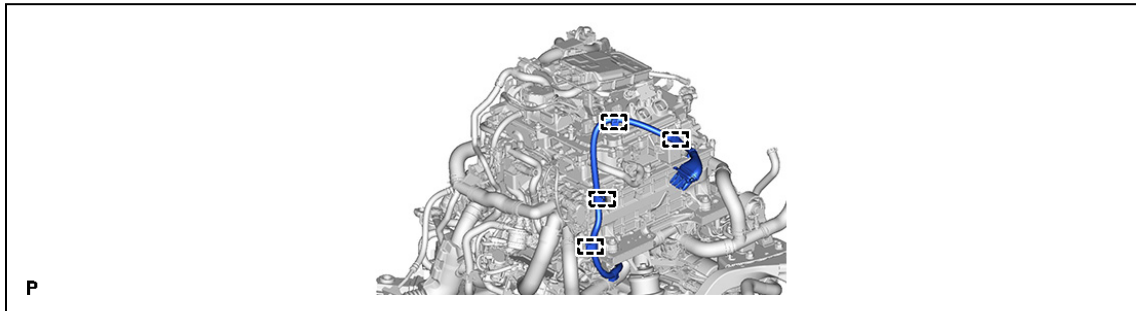

88. REMOVE FC STACK AIR OUTLET HOSE ASSEMBLY

a.

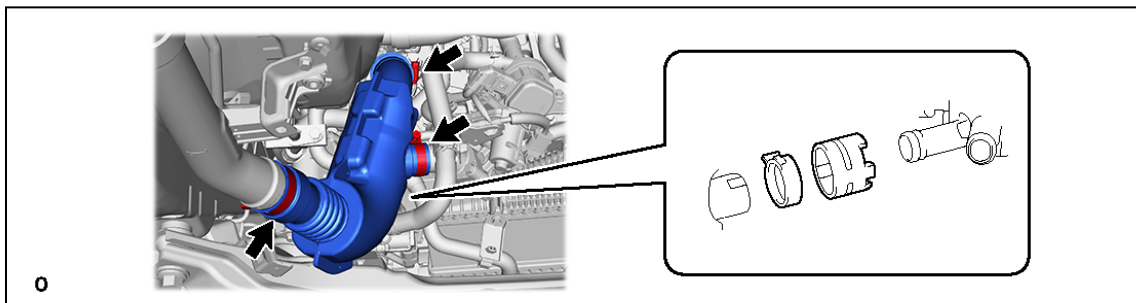

b.

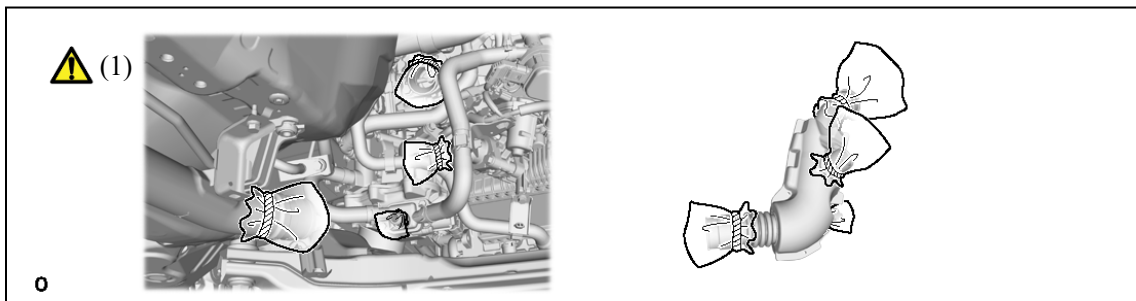

- (1) To prevent contamination by foreign matter or water droplets, cover the connecting portions of the FC stack air outlet hose and each pipe with plastic bags.

89. REMOVE FC AIR BY-PASS VALVE ASSEMBLY

a.

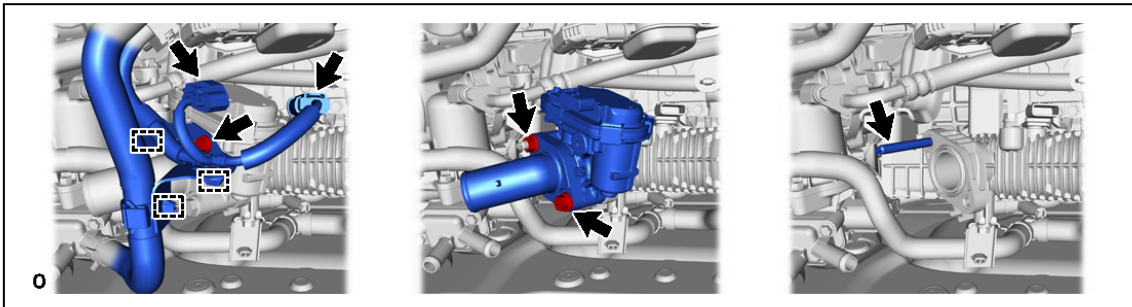

b.

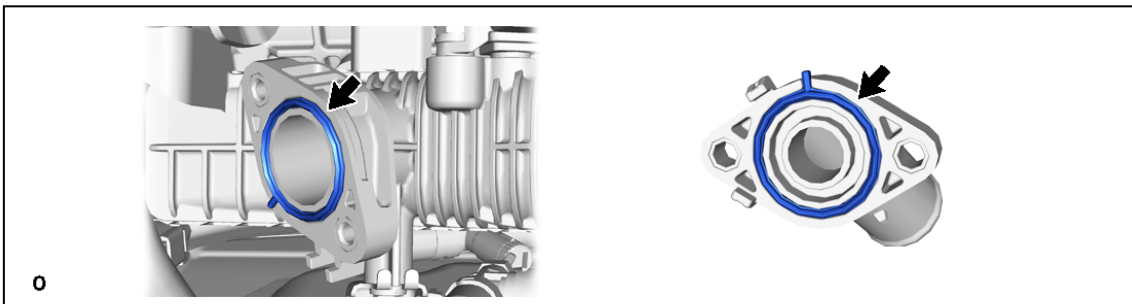

c.

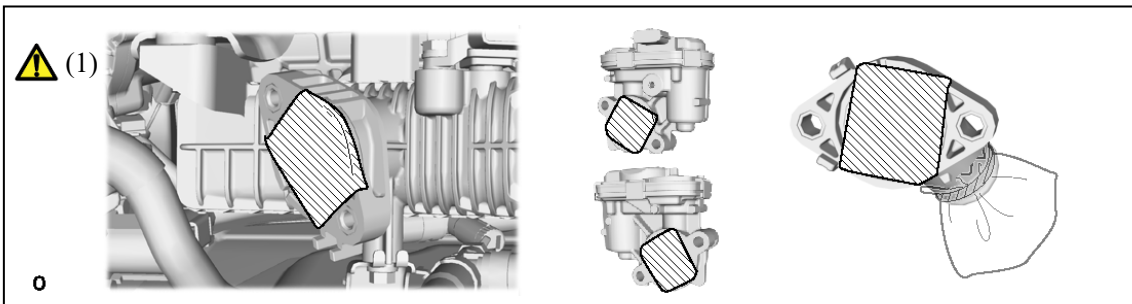

- (1) To prevent contamination by foreign matter or water droplets, cover the connecting portions of the FC air by-pass valve assembly, FC air by-pass valve pipe assembly and intercooler with sensor assembly with protective tape.

90. DISCONNECT FC INTERCOOLER HOSE

a.

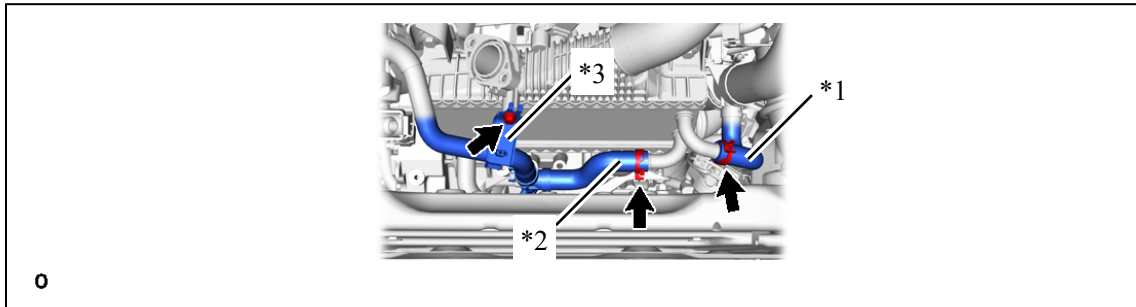

*1	No. 1 FC Intercooler Hose	*2	No. 2 FC Intercooler Hose
*3	No. 3 Radiator Hose Bracket	-	-

b.

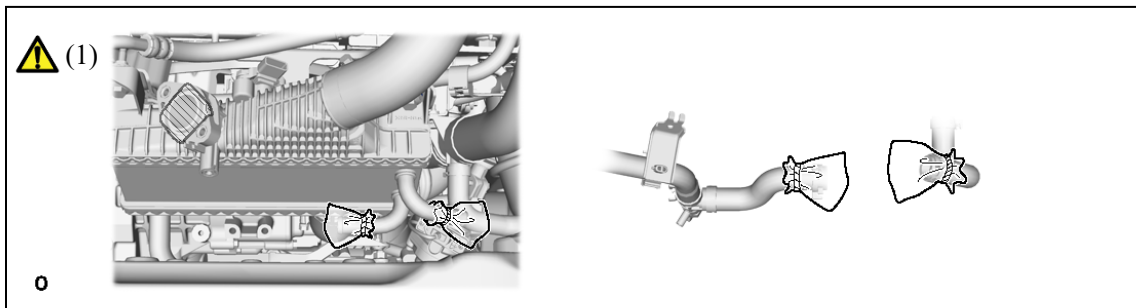

- (1) To prevent contamination by foreign matter or water droplets, cover the connecting portions of the No. 1 FC intercooler hose, No. 2 FC intercooler hose and intercooler with sensor assembly with plastic bags.

91. REMOVE FC STACK AIR INLET HOSE

a.

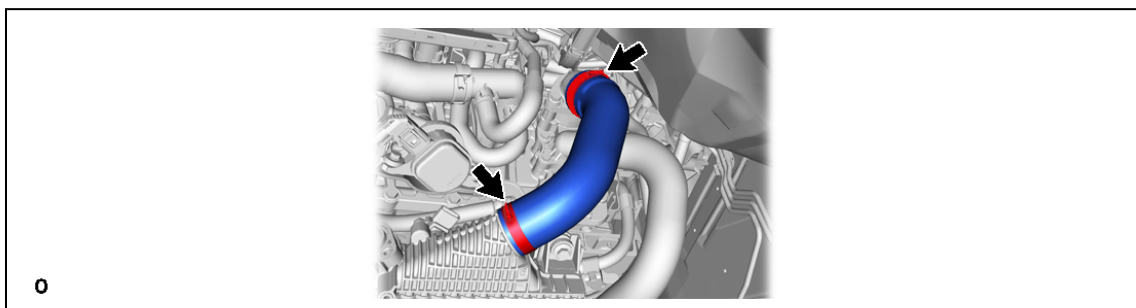

b.

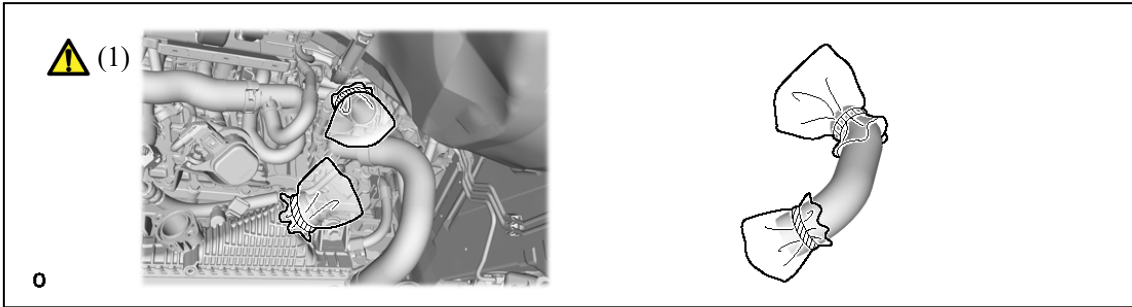

- (1) To prevent contamination by foreign matter or water droplets, cover the connecting portions of the FC stack air inlet hose, intercooler with sensor assembly and FC stack air inlet pipe assembly with plastic bags.

92. REMOVE INTERCOOLER ASSEMBLY WITH SENSOR

a.

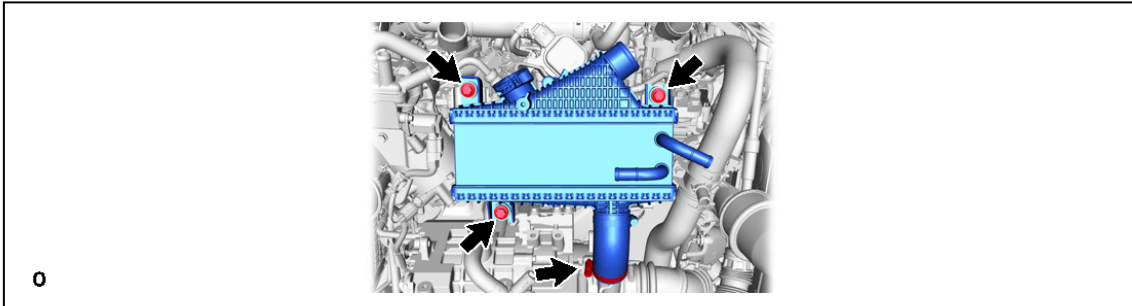

b.



- (1) To prevent contamination by foreign matter or water droplets, cover the connecting portions of the air hose and FC air compressor with motor assembly with plastic bags.

93. REMOVE WATER PUMP ASSEMBLY WITH MOTOR

a.

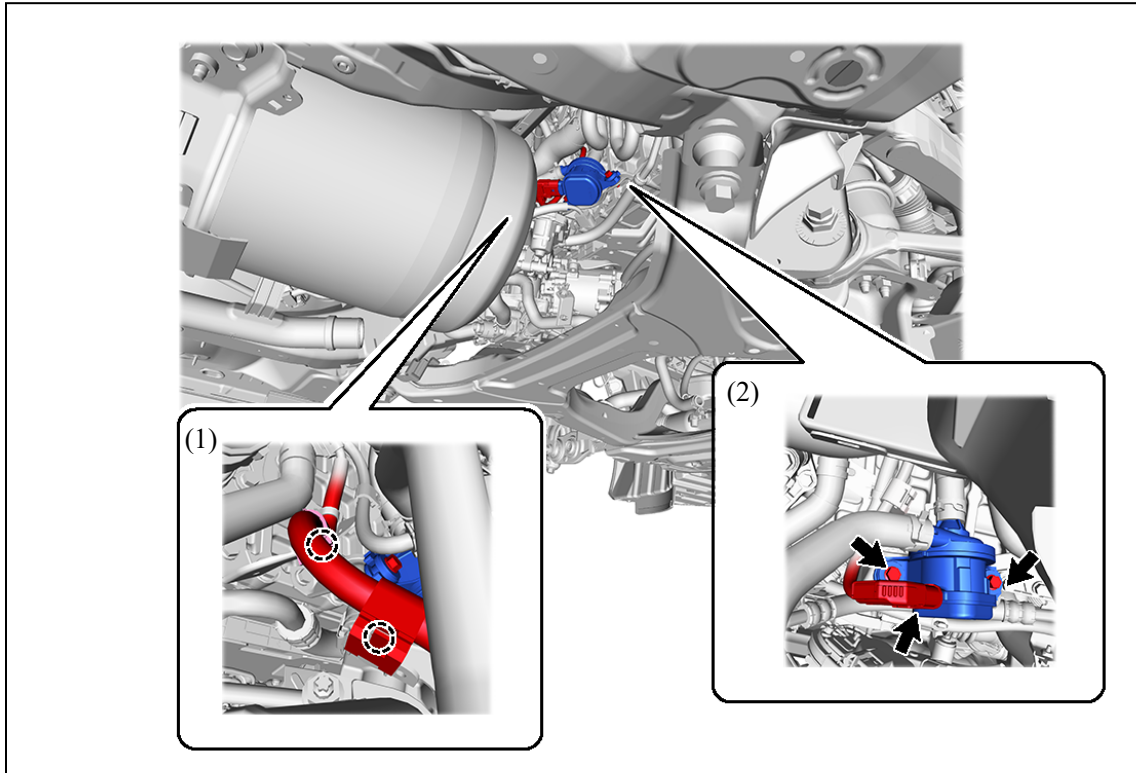

- (1) Detach the claw and disconnect the wire harness.
- (2) Disconnect the connector and remove the 2 bolts.

b.

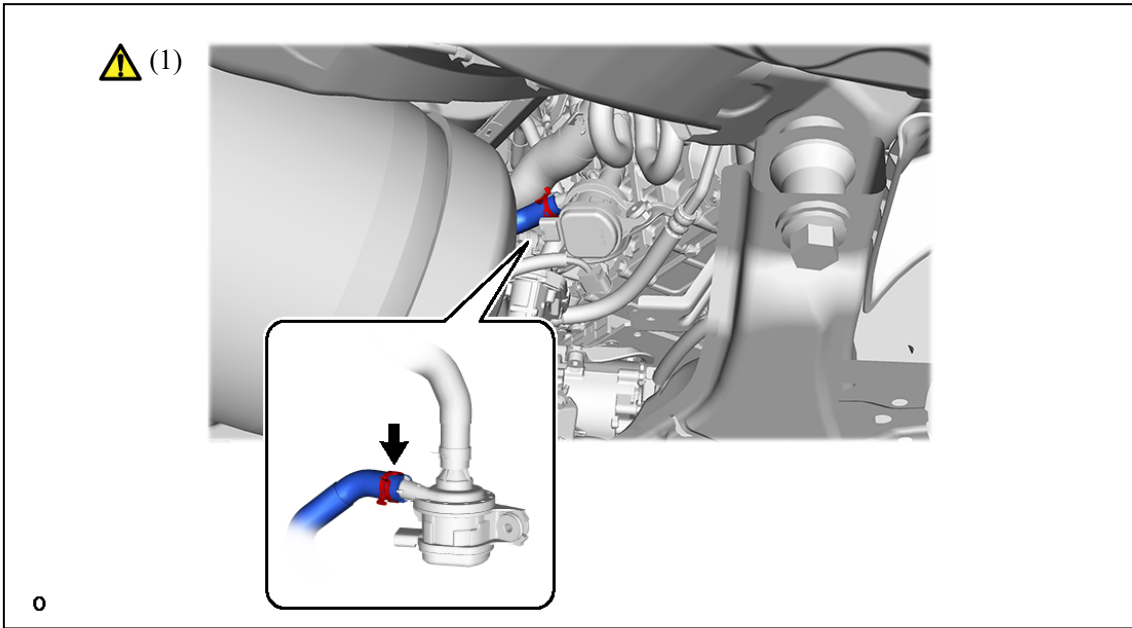

- (1) Using pliers, grip the claws of the clip and slide the clip to disconnect the water hose sub-assembly.

Notice:

Prepare a drain pan or cloth in case the coolant leaks.

c.

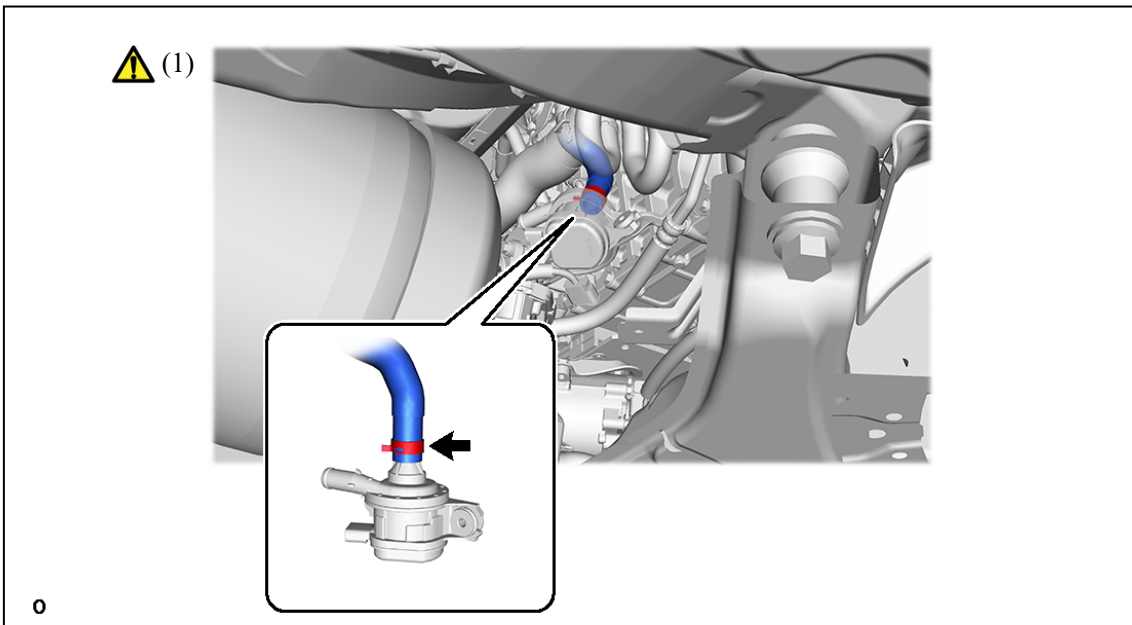

- (1) Using pliers, grip the claws of the clip and slide the clip to disconnect the heater accessory assembly.

Notice:

Prepare a drain pan or cloth in case the coolant leaks.

94. DISCONNECT WATER HOSE

a.

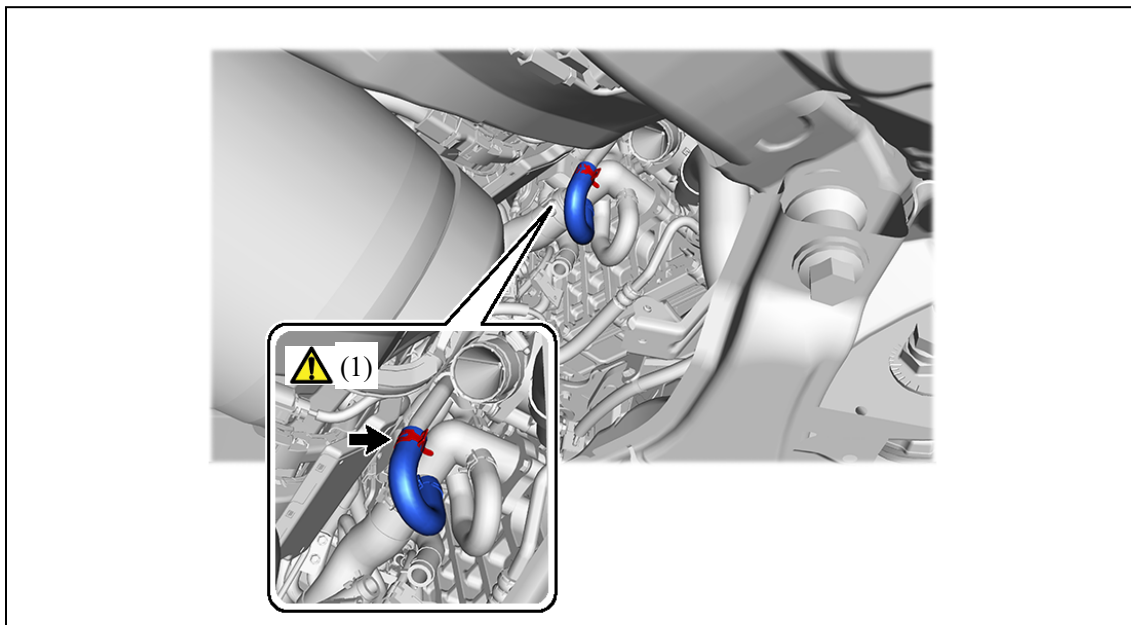

(1) Using pliers, grip the claws of the clip and slide the clip to disconnect the water hose.

Notice:

Prepare a drain pan or cloth in case the coolant leaks.

95. DISCONNECT HEATER ACCESSORY ASSEMBLY

a.

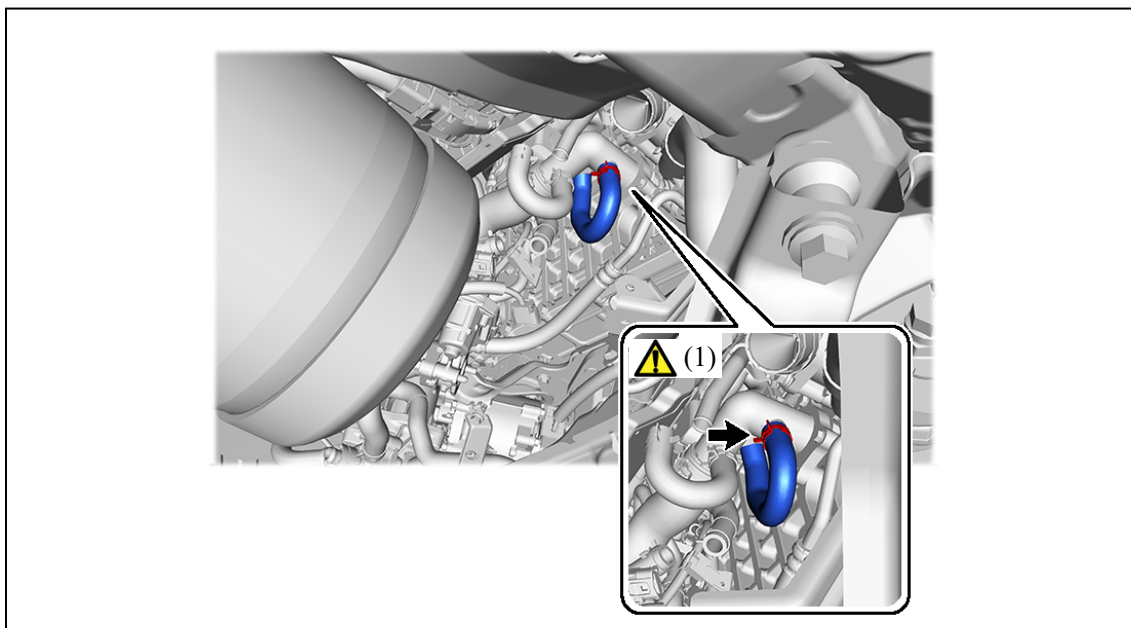

(1) Using pliers, grip the claws of the clip and slide the clip to disconnect the heater accessory assembly.

Notice:

Prepare a drain pan or cloth in case the coolant leaks.

96. DISCONNECT STACK WIRE

a.

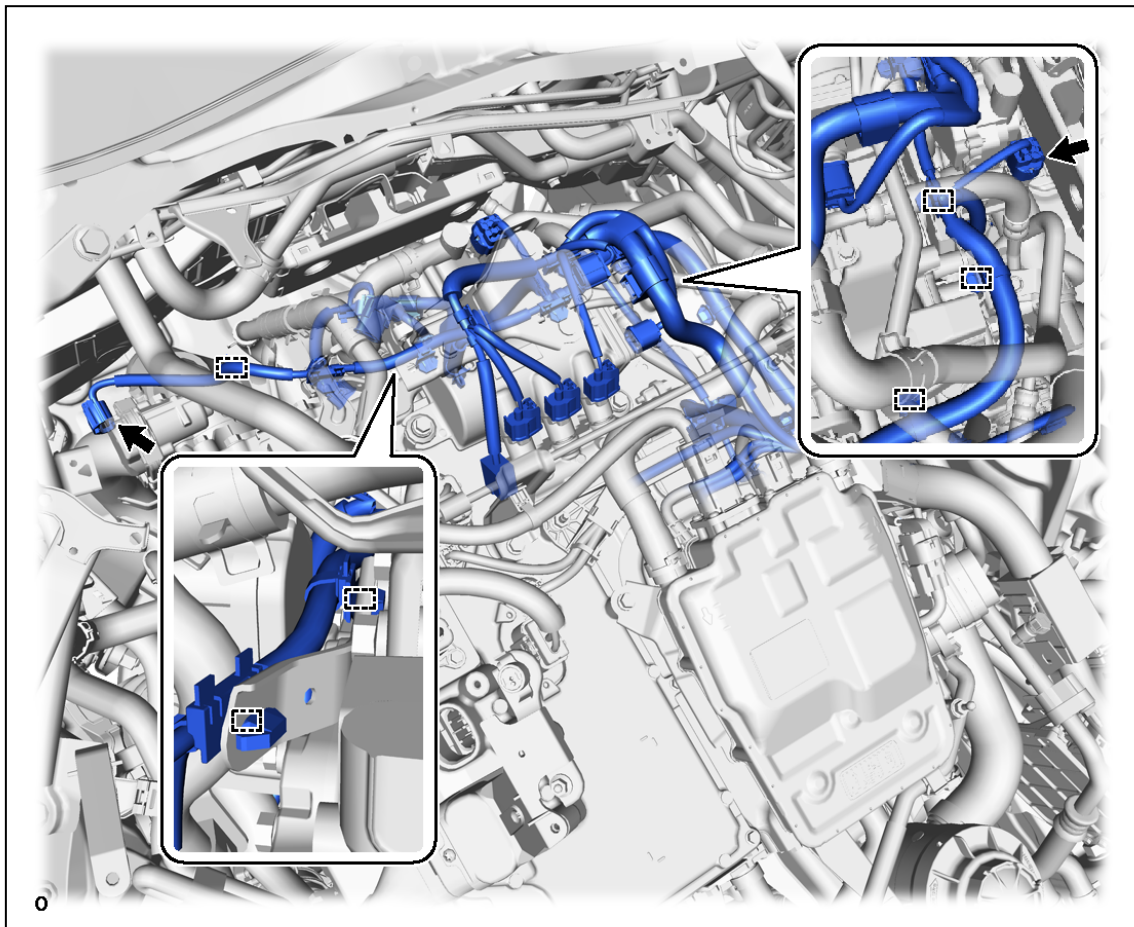

97. DISCONNECT WATER HOSE SUB-ASSEMBLY D

a.

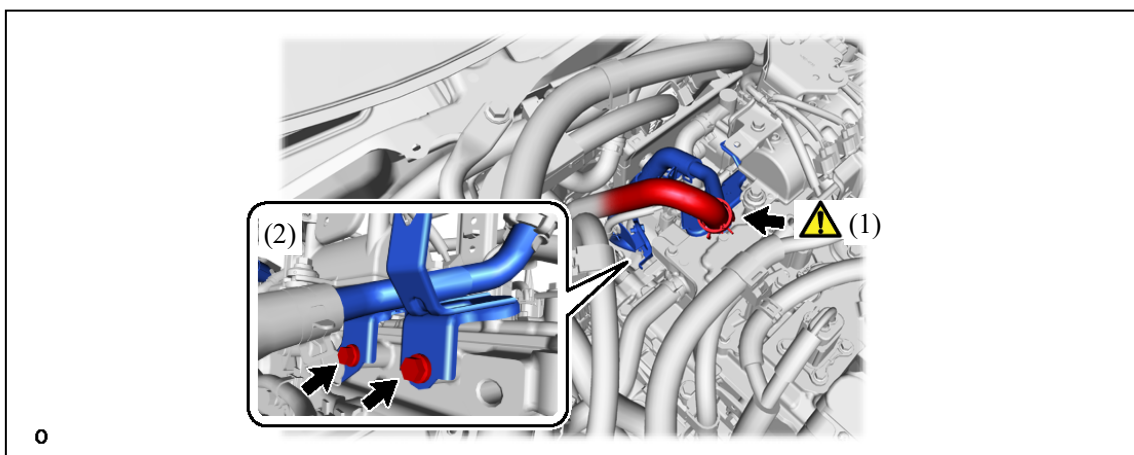

- (1) Using pliers, grip the claws of the clip and slide the clip to disconnect the water hose sub-assembly D.

Notice:

Prepare a drain pan or cloth in case the coolant leaks.

- (2) Remove the 2 bolts.

98. REMOVE HEATER ACCESSORY ASSEMBLY WITH WATER HOSE SUB-ASSEMBLY D

a.

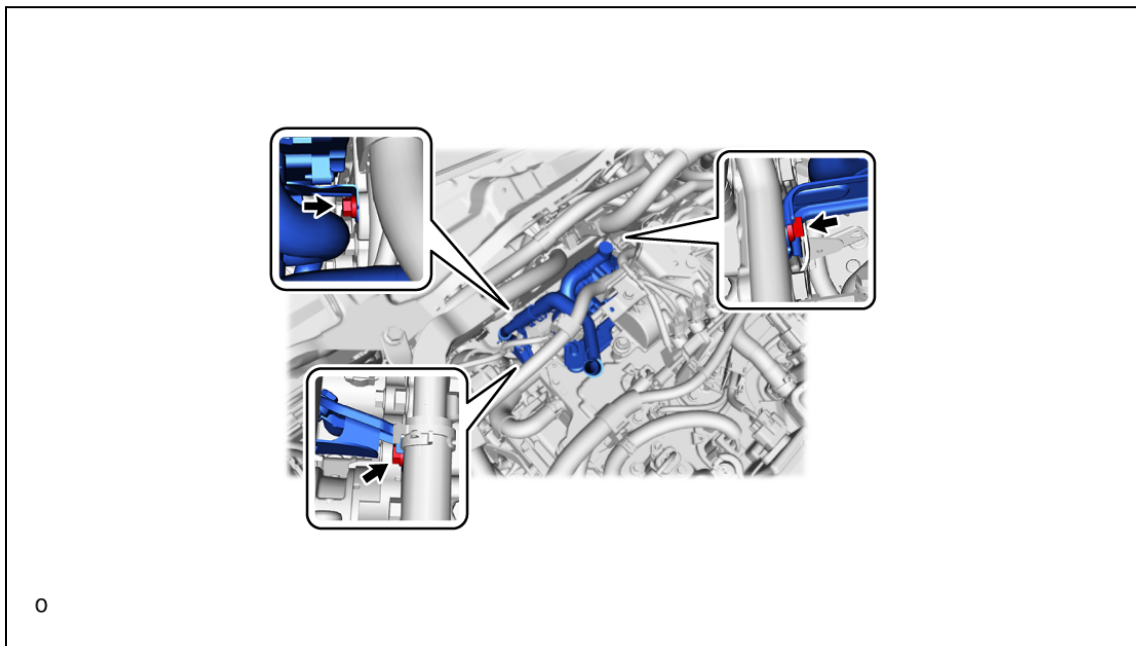

99. REMOVE NO. 9 FC RADIATOR HOSE

a.

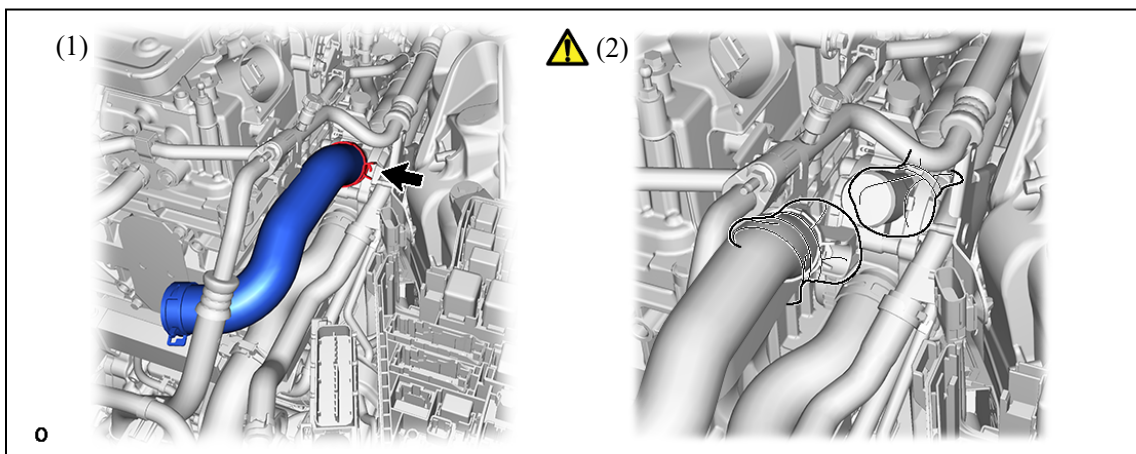

- (1) Slide the clip and remove the No. 9 FC radiator hose from the FC cooling water temperature sensor control valve.
- (2) To prevent contamination by foreign matter, cover the connecting portions of the No. 9 FC radiator hose and FC cooling water temperature control valve with plastic bags.

100. REMOVE FC COOLING WATER TEMPERATURE CONTROL VALVE

a.

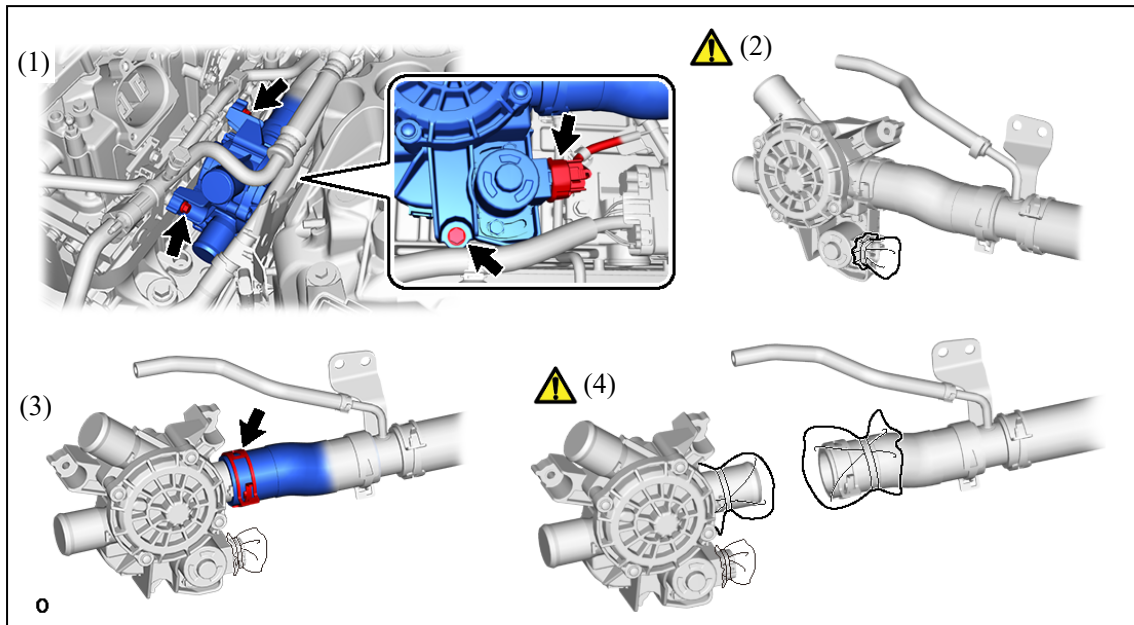

- (1) Remove the 3 bolts and disconnect the connector.
- (2) To prevent contamination by foreign matter, cover the connecting portions of the FC cooling water temperature control valve with plastic bags.
- (3) Slide the clip and remove the No. 6 FC radiator hose from the FC cooling water temperature sensor control valve.
- (4) To prevent contamination by foreign matter, cover the connecting portions of the No. 6 FC radiator hose and FC cooling water temperature control valve with plastic bags. ■

101. REMOVE NO. 6 FC RADIATOR HOSE

a.

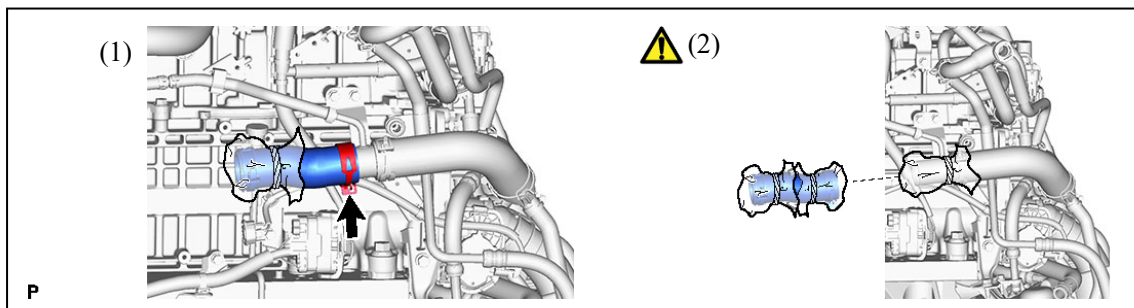

102. Slide the clip, remove the No. 6 FC radiator hose.

103. Cover the connection of the No. 6 FC radiator hose and No. 4 FC radiator pipe with plastic bags to prevent the foreign matter.

104. REMOVE RESERVE TANK INLET HOSE

a.

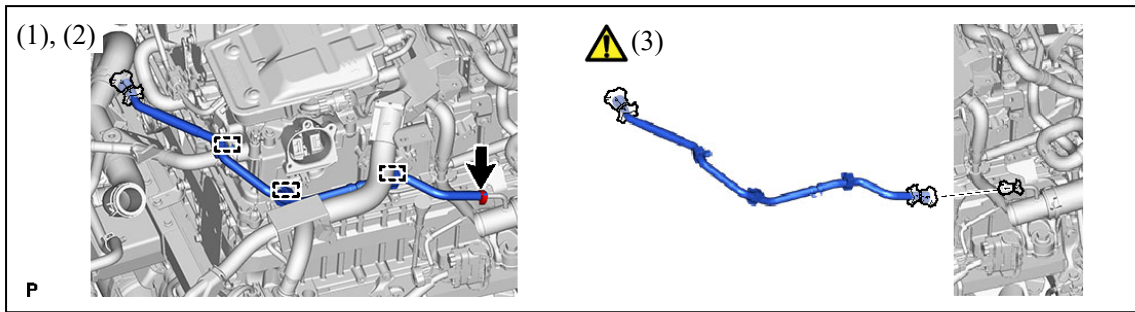

- (1) Detach the 3 clamps.
- (2) Slide the clip, remove the reserve tank inlet hose.
- (3) Cover the connection of the reserve tank inlet hose and No. 4 FC radiator pipe with plastic bags to prevent the foreign matter.

105. DISCONNECT NO. 3 FC INTERCOOLER HOSE

a.

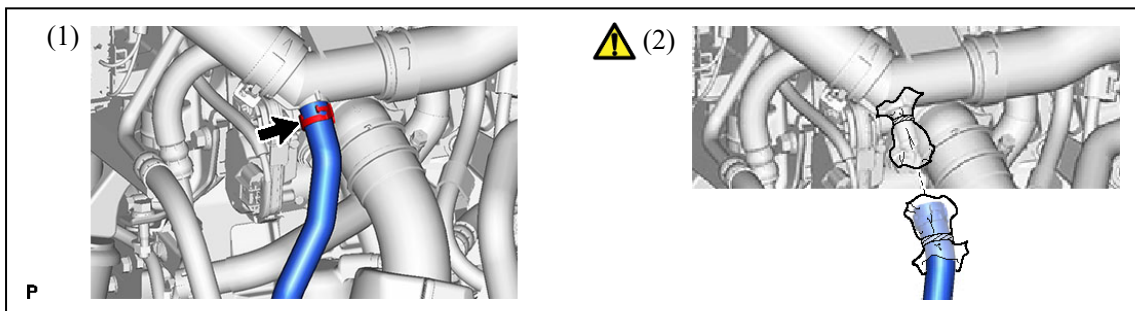

- (1) Slide the clip, remove the No. 3 FC intercooler hose.
- (2) Cover the connection of the No. 3 FC intercooler hose and No. 3 FC radiator pipe with plastic bags to prevent the foreign matter.

106. REMOVE NO. 3 FC RADIATOR PIPE AND NO. 4 FC RADIATOR PIPE

a.

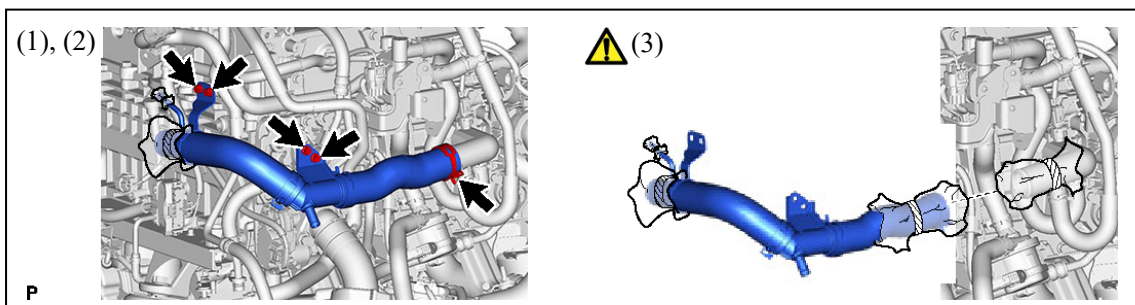

- (1) Slide the clip, disconnect the No. 4 FC radiator hose.
- (2) Remove the 4 bolts, No. 3 FC radiator pipe and No. 4 FC radiator pipe.
- (3) Cover the connection of the No. 4 FC radiator hose and FC stack water outlet with plastic bags to prevent the foreign matter.

107. REMOVE WATER HOSE SUB-ASSEMBLY B

a.

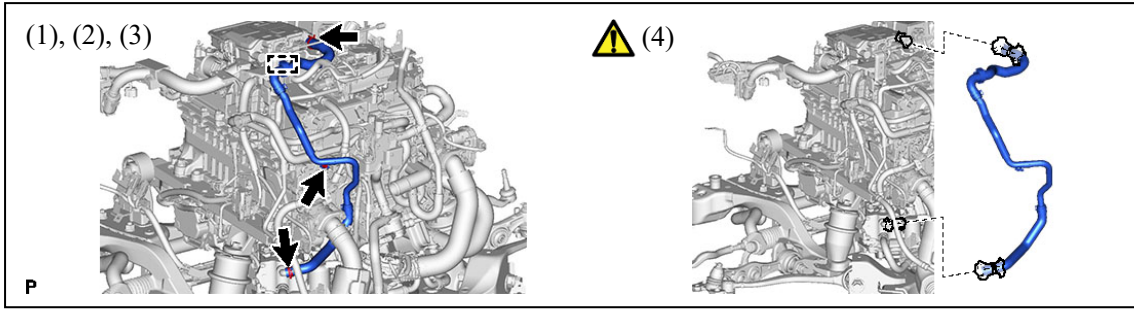

- (1) Detach the clamp.
- (2) Slide the 2 clips, disconnect the water hose sub-assembly B.
- (3) Remove the bolt and water hose sub-assembly B.
- (4) Cover the connection of the water hose sub-assembly B, hydrogen recirculation pump assembly with hydrogen recirculation separator assembly and electric heater sub-assembly with plastic bags to prevent the foreign matter.

108. REMOVE ELECTRIC HEATER SUB-ASSEMBLY

a.

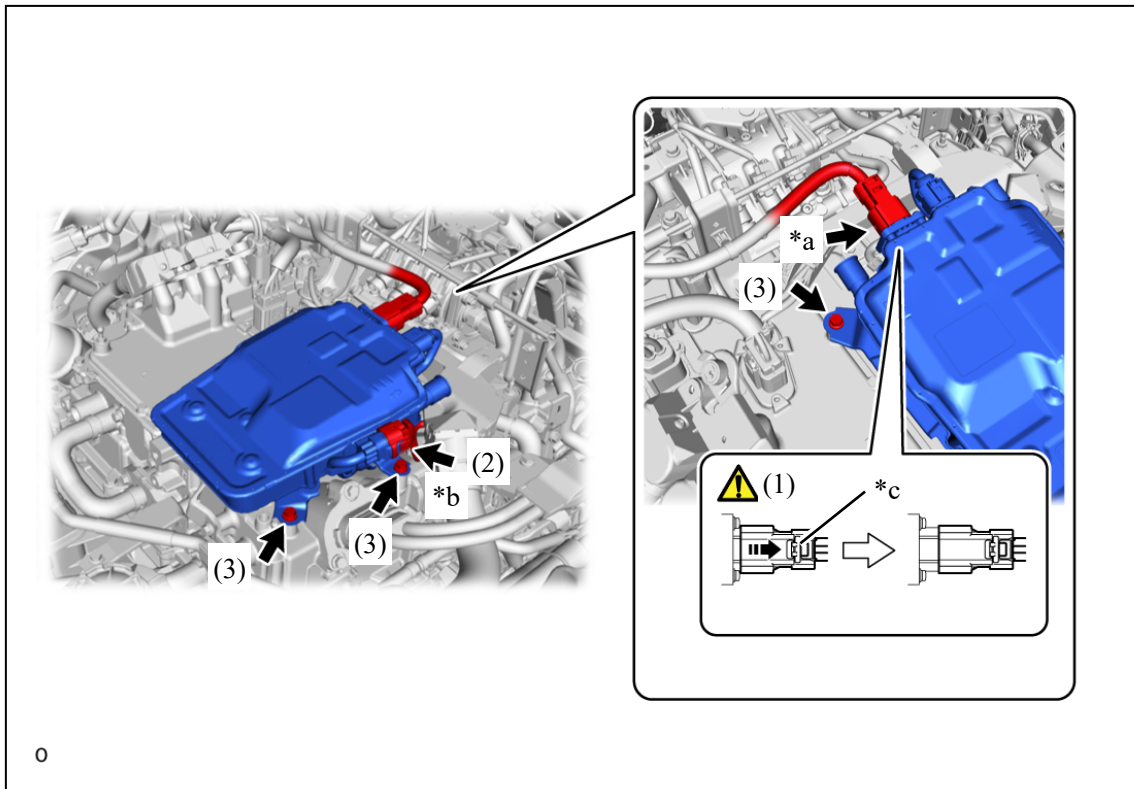

*a	Connector (A)	*b	Connector (B)
*c	Green-colored Lock	-	-
	Slide	-	-

- (1) Slide the green-colored lock of the connector (A) as shown in the illustration to release it and disconnect the connector.

Caution:

Wear insulated gloves.

Notice:

Insulate the disconnected terminals and connector with vinyl tape.

- (2) Disconnect the connector (B).
- (3) Remove the 3 bolts and electric heater sub-assembly.

109. REMOVE FC STACK COVER BRACKET

a.

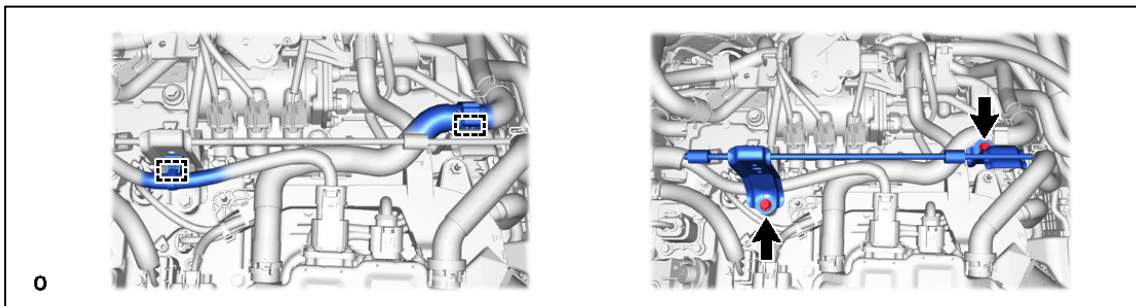

110. REMOVE WIRE HARNESS

a.

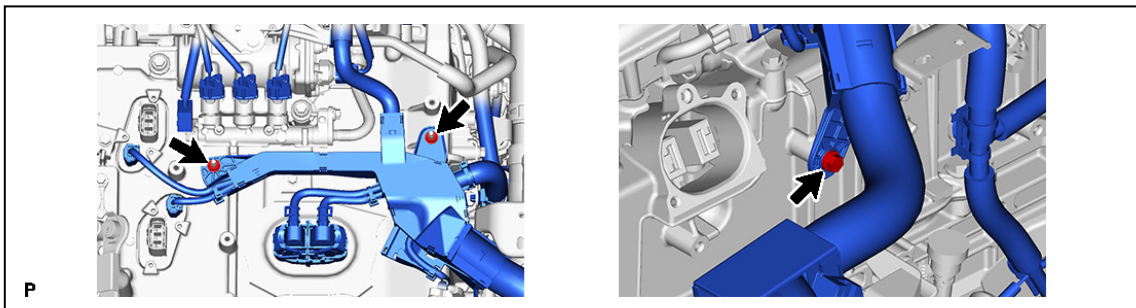

b.

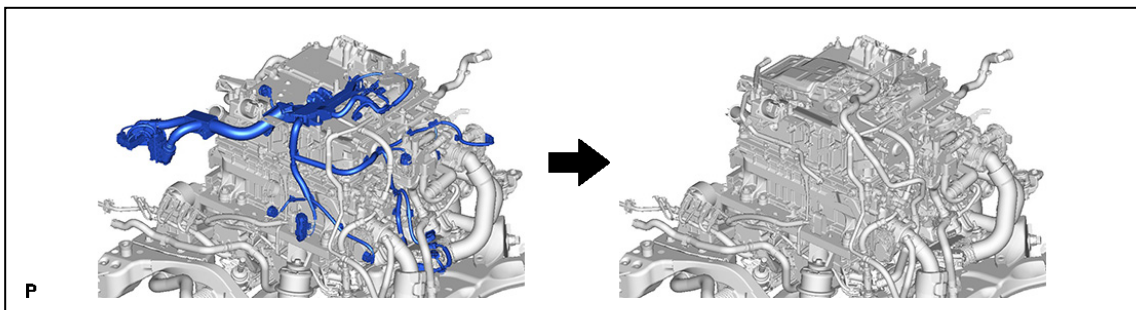

111. REMOVE NO. 1 FC INVERTER COOLING HOSE SUB-ASSEMBLY

a.

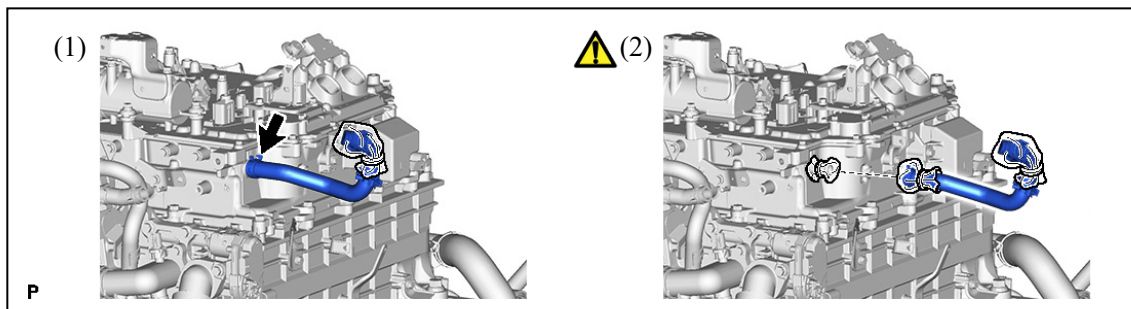

- (1) Slide the clip, remove the No. 1 FC inverter cooling hose sub-assembly.
- (2) Cover the connection of the No. 1 FC inverter cooling hose sub-assembly and FC converter assembly with plastic bags to prevent the foreign matter.

112. REMOVE NO. 2 HYDROGEN PUMP BRACKET

a.

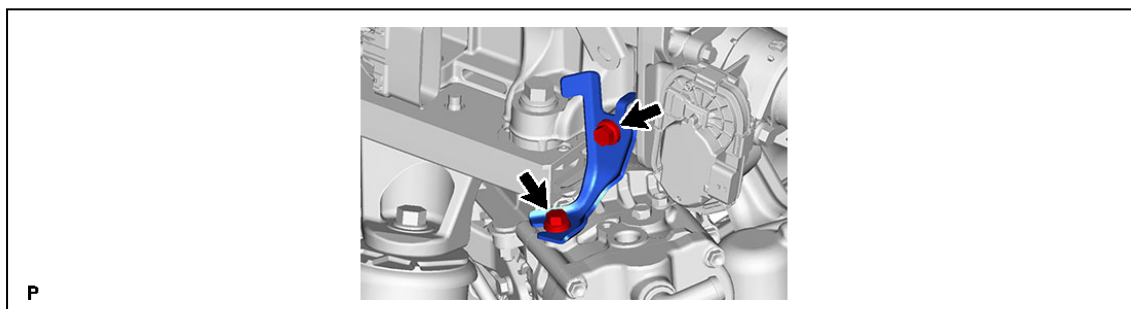

113. REMOVE NO. 5 FC INVERTER COOLING HOSE

a.

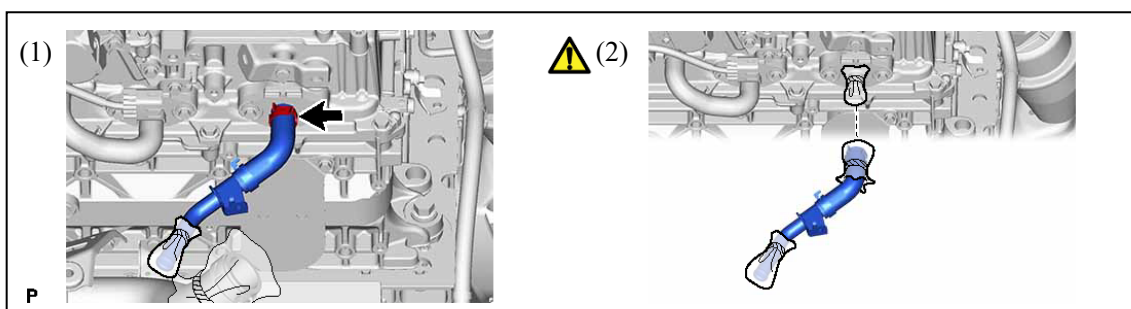

- (1) Slide the clip, remove the No. 5 FC inverter cooling hose.
- (2) Cover the connection of the No. 5 FC inverter cooling hose and FC converter assembly with plastic bags to prevent the foreign matter.

114.REMOVE NO. 6 FC RADIATOR PIPE

a.

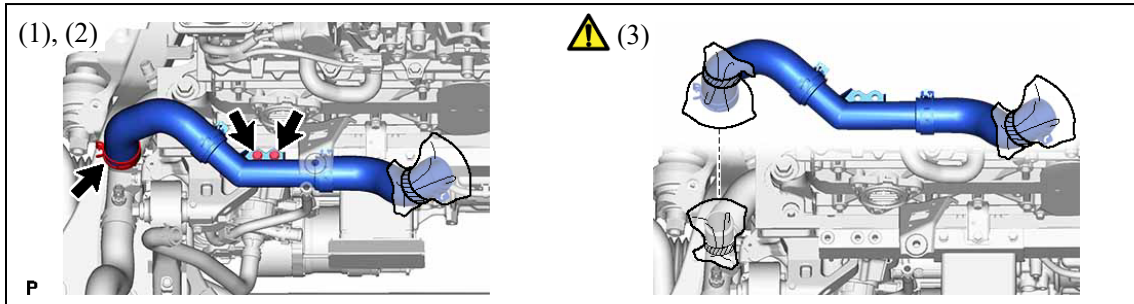

- (1) Slide the clip, disconnect the No. 12 FC radiator hose.
- (2) Remove the 2 bolts and No. 6 FC radiator pipe.
- (3) Cover the connection of the No. 12 FC radiator hose and No. 6 FC radiator pipe with plastic bags to prevent the foreign matter.

115.REMOVE RADIATOR RESERVE TANK BRACKET

a.

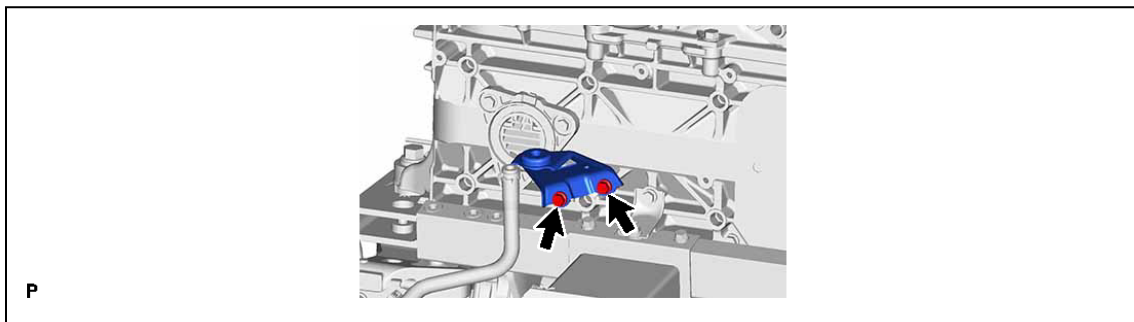

116.REMOVE FC AIR COMPRESSOR BREATHER ASSEMBLY

a.

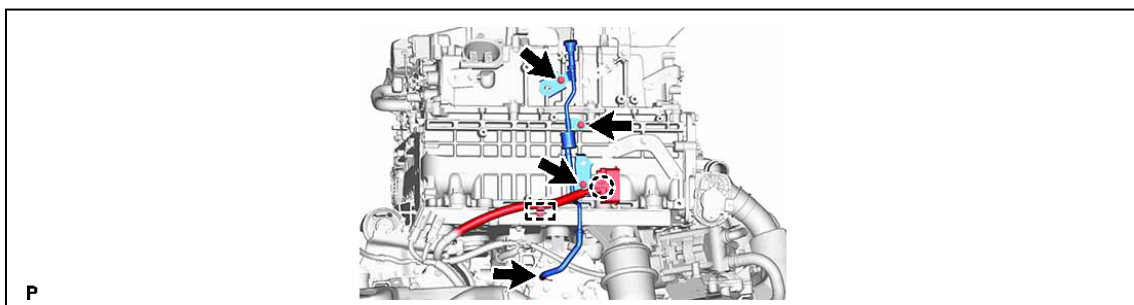

117. REMOVE NO. 3 FC RADIATOR HOSE

a.

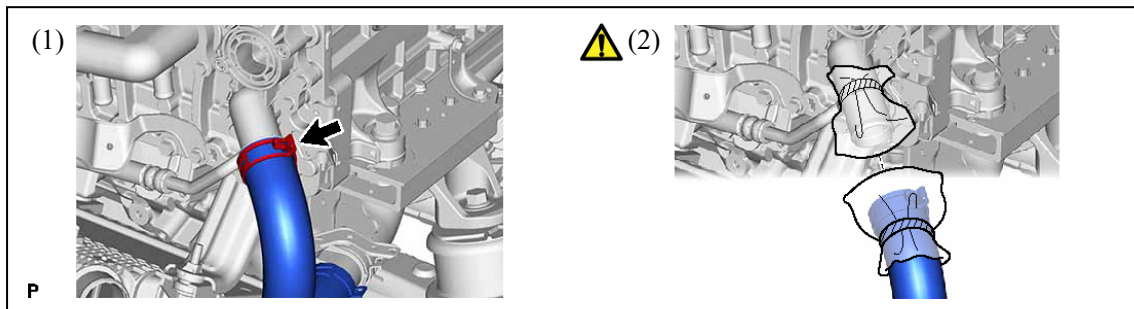

- (1) Slide the clip, disconnect the No. 3 FC radiator hose.
- (2) Cover the connection of the No. 3 FC radiator hose and FC stack air and water inlet with plastic bags to prevent the foreign matter.

118. REMOVE NO. 3 HYDROGEN TUBE

a.

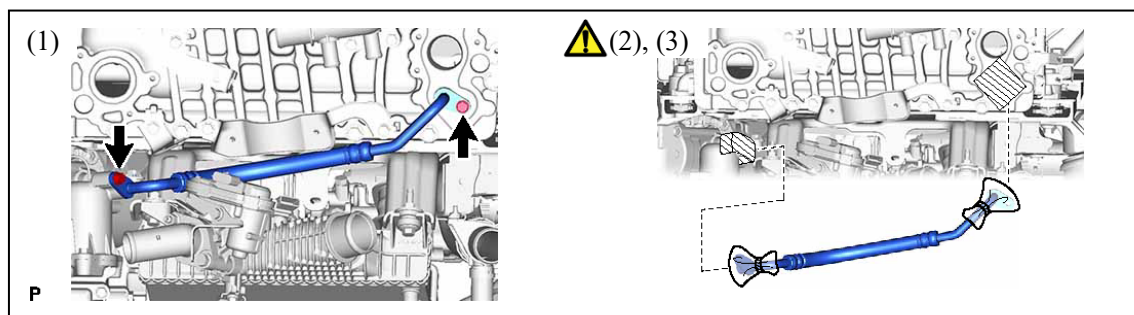

- (1) Remove the 2 bolts and No. 3 hydrogen tube.
- (2) Cover the connection of the No. 3 hydrogen tube with plastic bags to prevent the foreign matter.
- (3) Protect the openings of the FC stack assembly and hydrogen recirculation pump assembly with protective tape (non-residue type) to prevent the entry of foreign matter or water.

119. REMOVE WATER PUMP BRACKET

a.

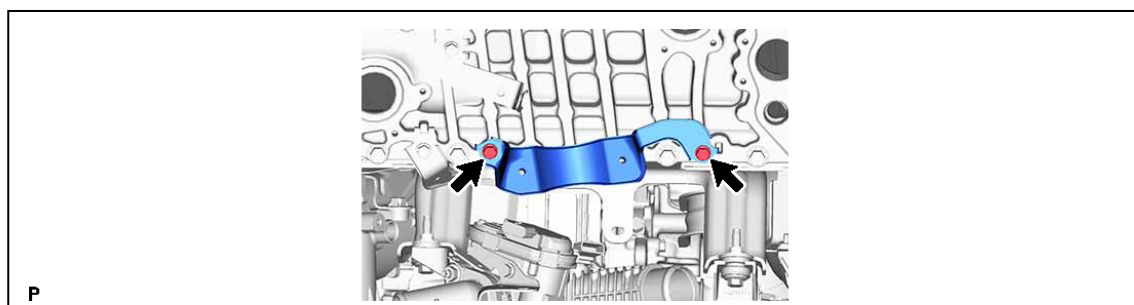

120. REMOVE FC CONVERTER SUPPORT PLATE

a.

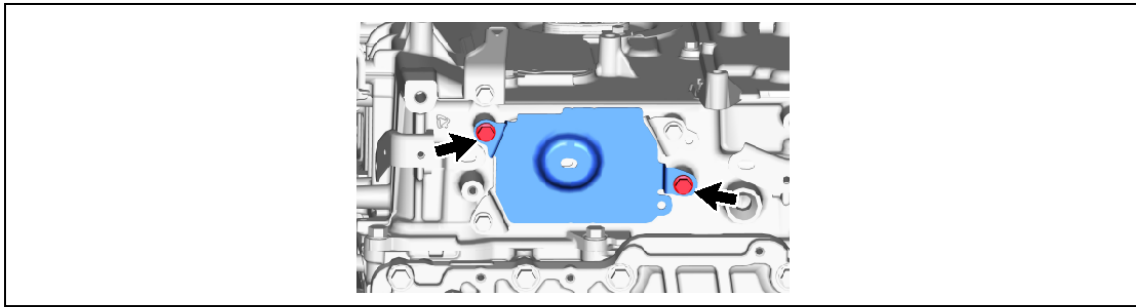

121. REMOVE FC CONVERTER SPACER

a.

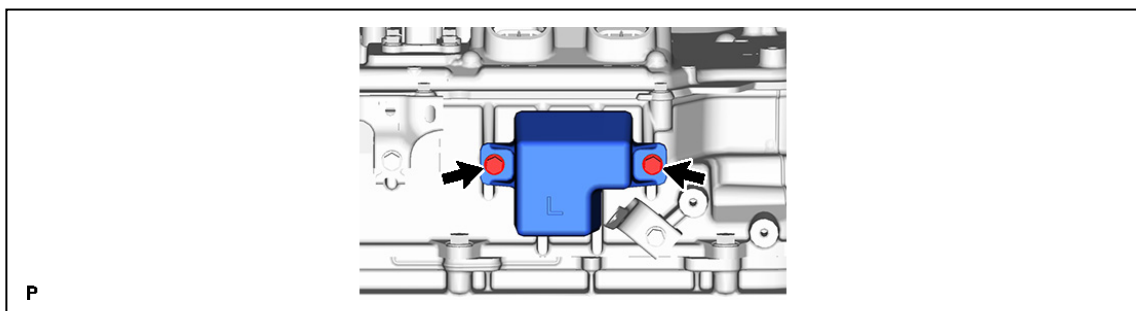

122. REMOVE NO. 7 RADIATOR HOSE BRACKET

a.

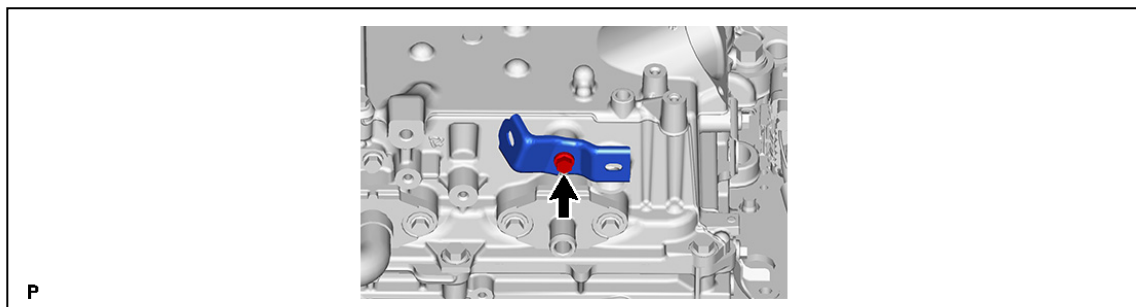

123. REMOVE NO. 5 RADIATOR HOSE BRACKET

a.

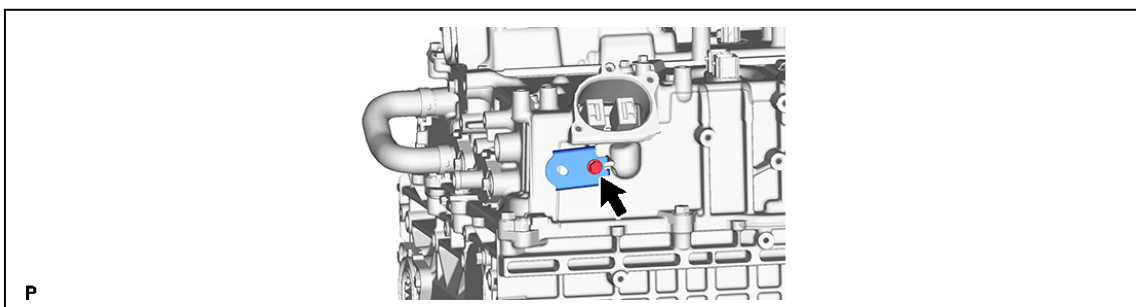

124. REMOVE FC CONVERTER POWER OUTLET BRACKET

a.

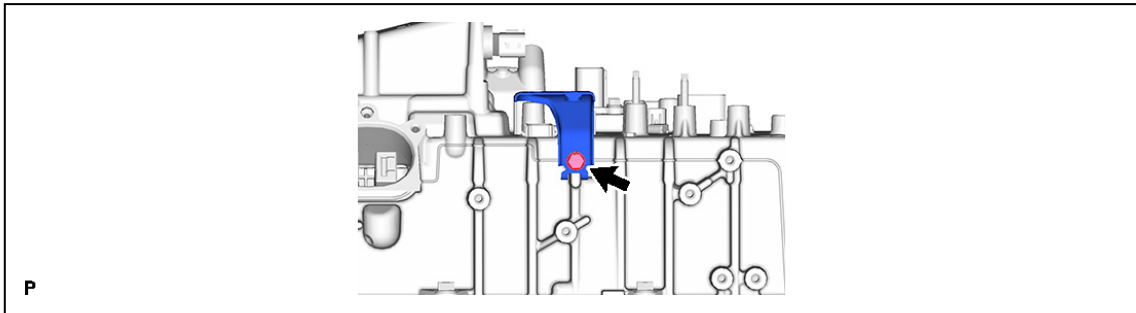

125. REMOVE NO. 1 HEATER BRACKET

a.

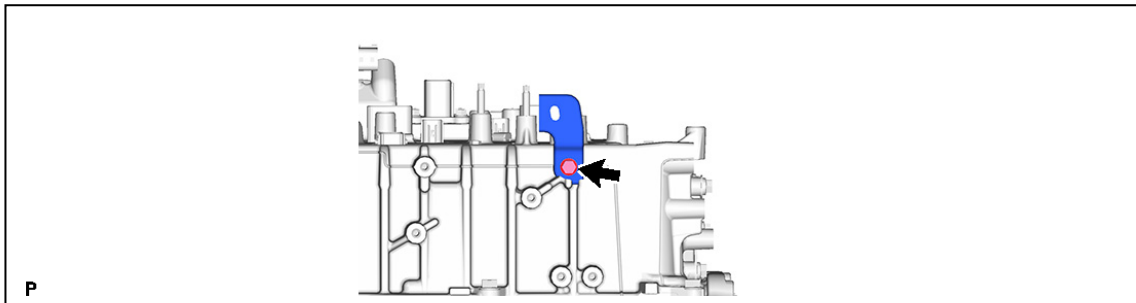

126. REMOVE NO. 1 FC COOLING WATER PUMP CABLE BRACKET

a.

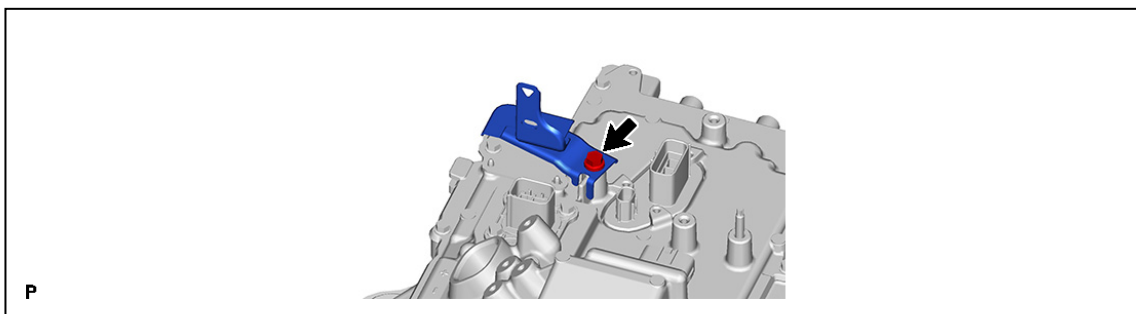

127. REMOVE NO. 2 FC COOLING WATER PUMP CABLE BRACKET

a.

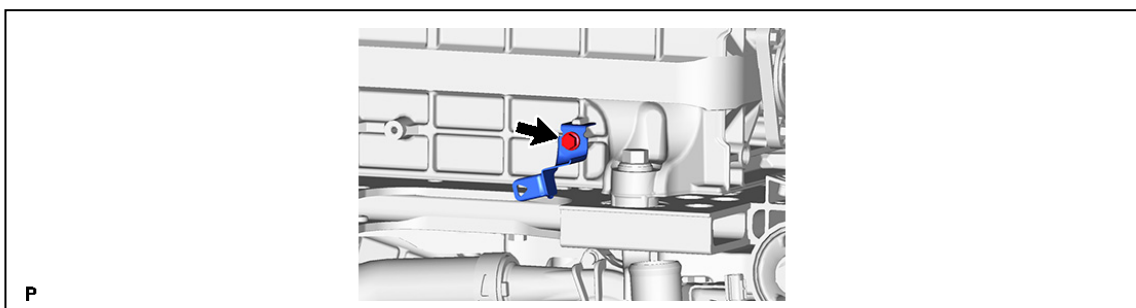

128.REMOVE NO. 3 FC JUNCTION CABLE BRACKET

a.

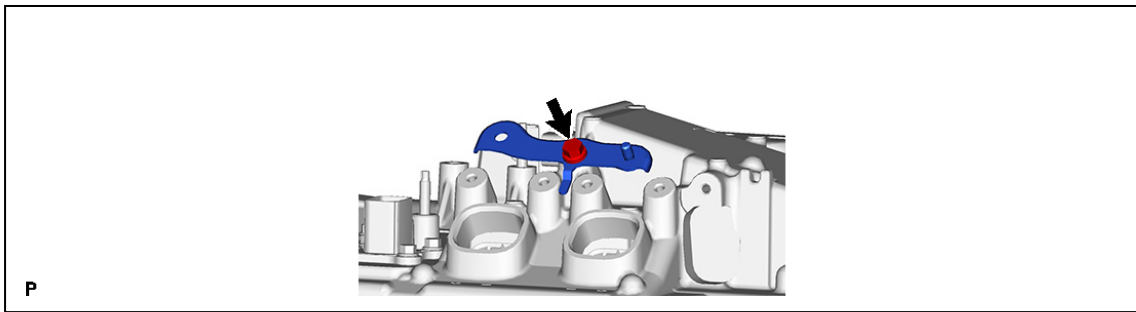

129.REMOVE NO. 1 FC JUNCTION CABLE BRACKET

a.

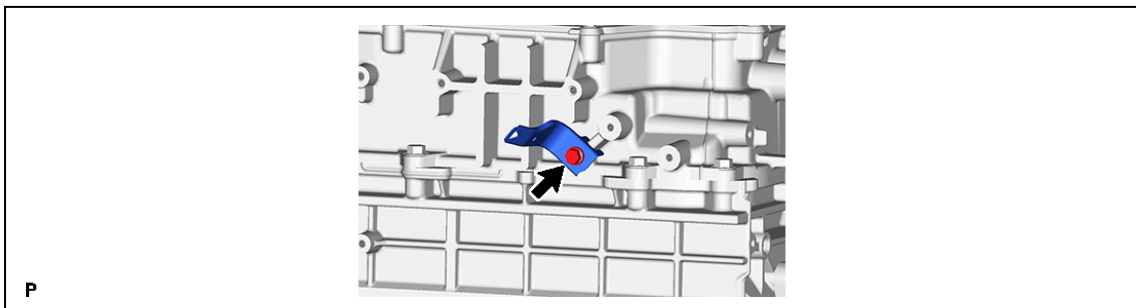

130.REMOVE NO. 1 FC WATER AND HYDROGEN PUMP CABLE BRACKET

a.

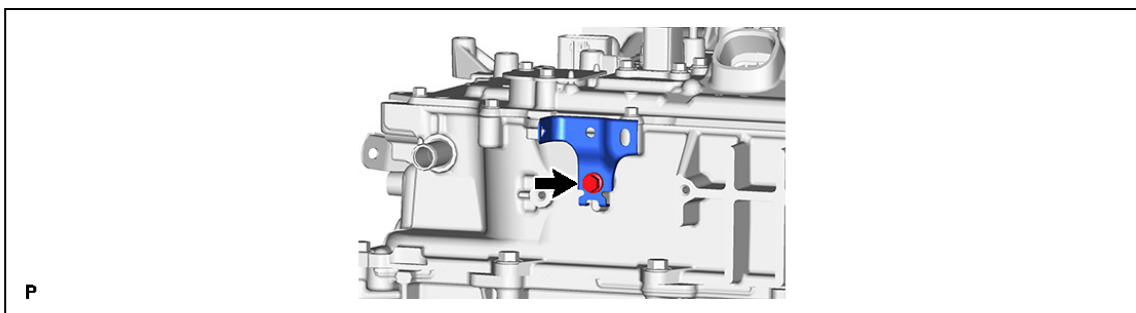

131.REMOVE NO. 2 FC WATER AND HYDROGEN PUMP CABLE BRACKET

a.

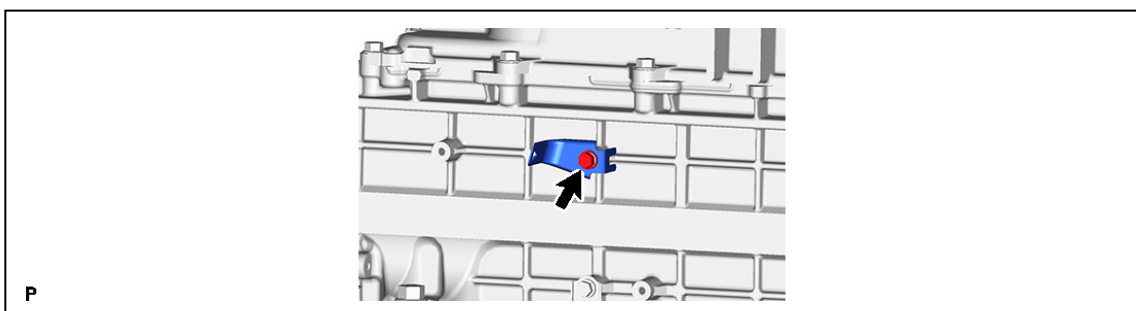

132. REMOVE NO. 3 FC WATER AND HYDROGEN PUMP CABLE BRACKET

a.

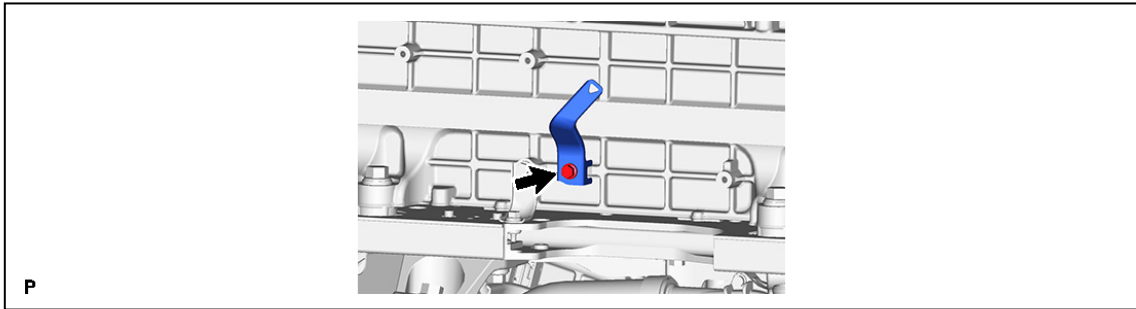

133. REMOVE NO. 1 FC AIR COMPRESSOR CABLE BRACKET

a.

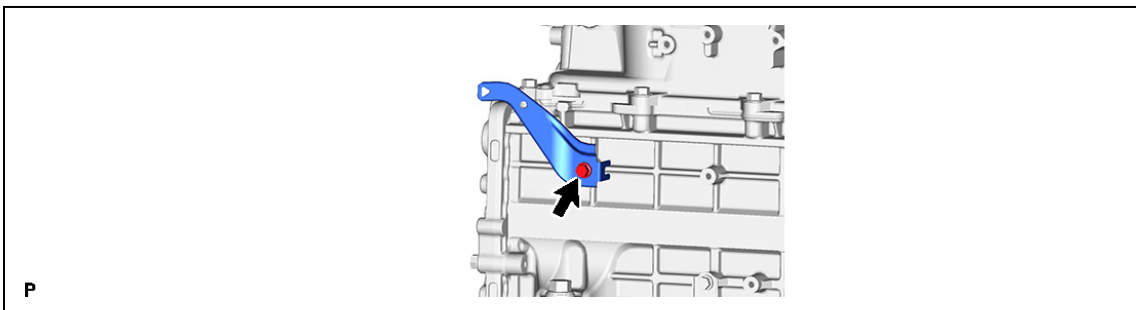

134. REMOVE NO. 4 FC AIR COMPRESSOR CABLE BRACKET

a.

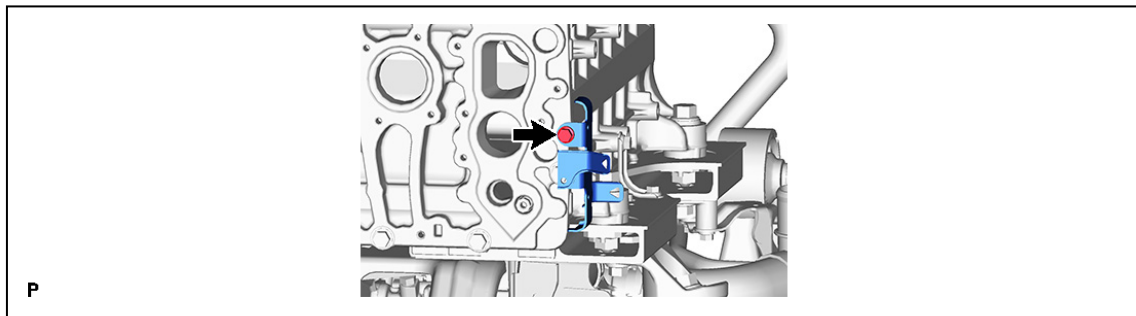

135. REMOVE WIRE HARNESS CLAMP BRACKET

a.

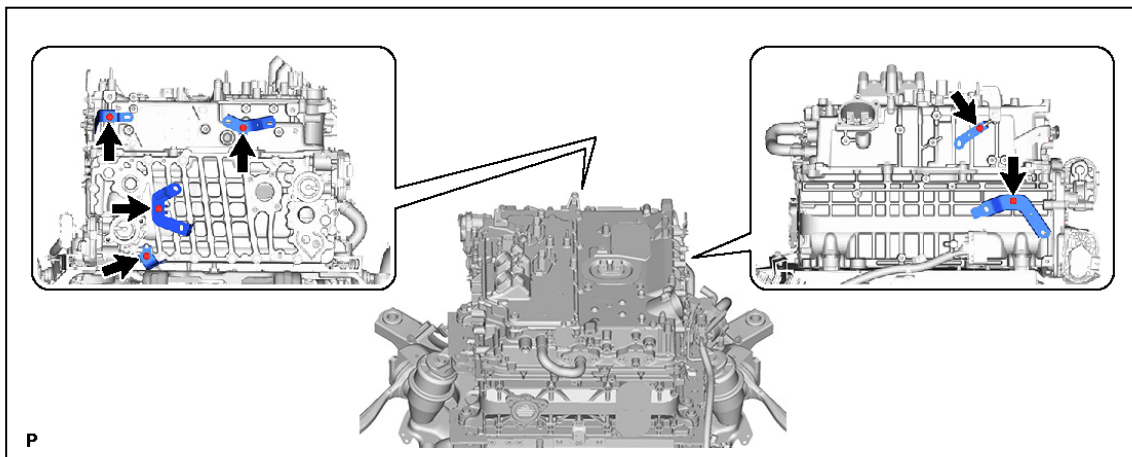

136. REMOVE HYDROGEN DETECTOR

a.

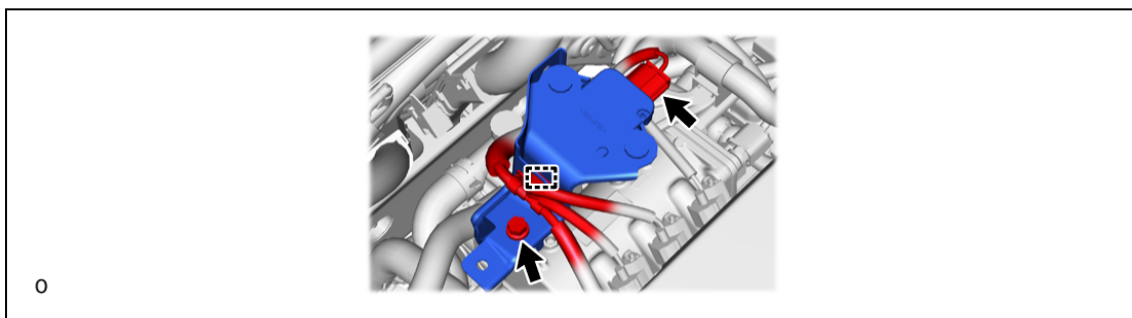

Perform Electrical Charge Self-discharge

1. PERFORM ELECTRICAL CHARGE SELF-DISCHARGE (WHEN FORCED ELECTRICAL CHARGE DISCHARGE NOT POSSIBLE)



CAUTION:

- Since high voltage accumulates within the FC stack assembly with FC converter, never perform the work of separating this part into the FC converter assembly and FC stack assembly without first discharging the electrical charge (electrical charge self-discharge), because doing so is dangerous.
- Be sure to reduce the voltage within the FC stack assembly with FC converter to a level where work can be performed safely by performing electrical charge self-discharge. (This work is unnecessary if forced electrical charge discharge has been completed.)

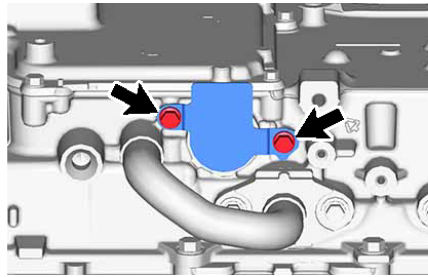

P

- a. Remove the front FC converter service hole cover.

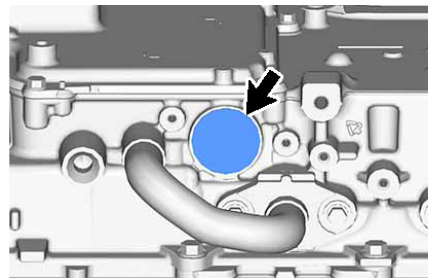

P

- b. Remove the No. 1 FC stack case plug.

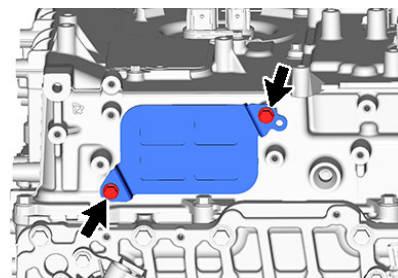

- c. Remove the FC converter vent cover.

- d. Measure the voltage according to the value(s) in the table below.

Standard Voltage:

Tester Connection	Specified Condition
Front side (positive terminal) - rear side (negative terminal)	Below 25 V

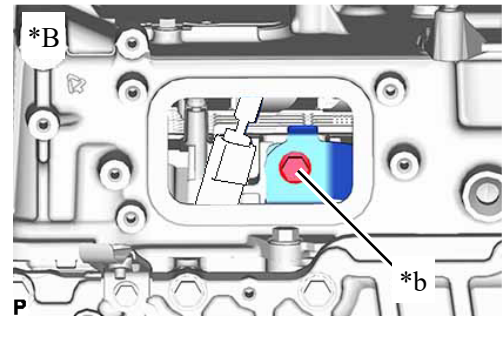
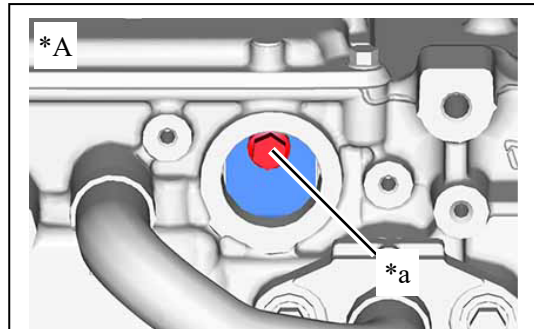

*A	Front Side
*B	Rear Side
*a	Positive Terminal
*b	Negative Terminal

- e. Remove the 2 bolts and FC air pressure regulator assembly (air sealing valve).

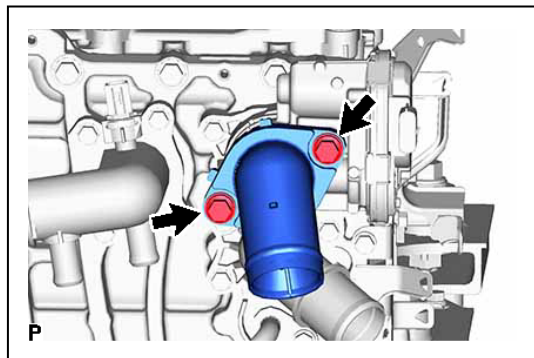

- f. Remove the 2 gaskets from the FC stack air inlet pipe assembly and FC stack air and water inlet.

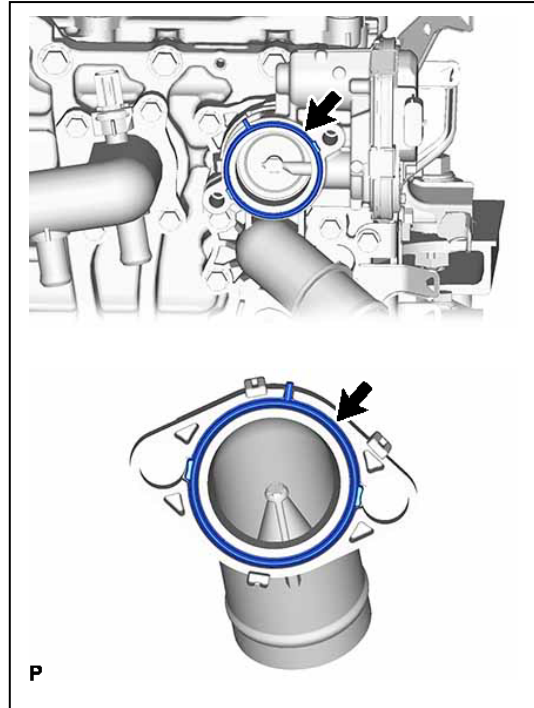

- g. To prevent contamination by foreign matter or water droplets, cover the connecting portions of the FC air pressure regulator assembly (air sealing valve) and FC stack air inlet pipe assembly with protective tape.

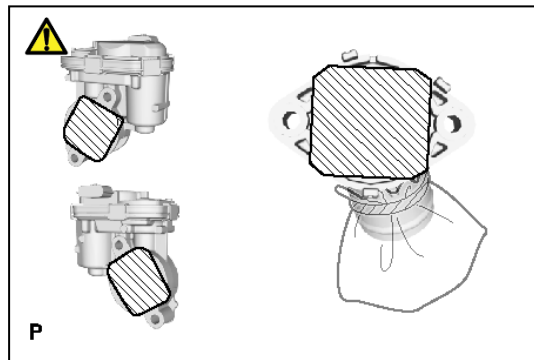

- h. Leave the vehicle as is for 2 hours.

i.

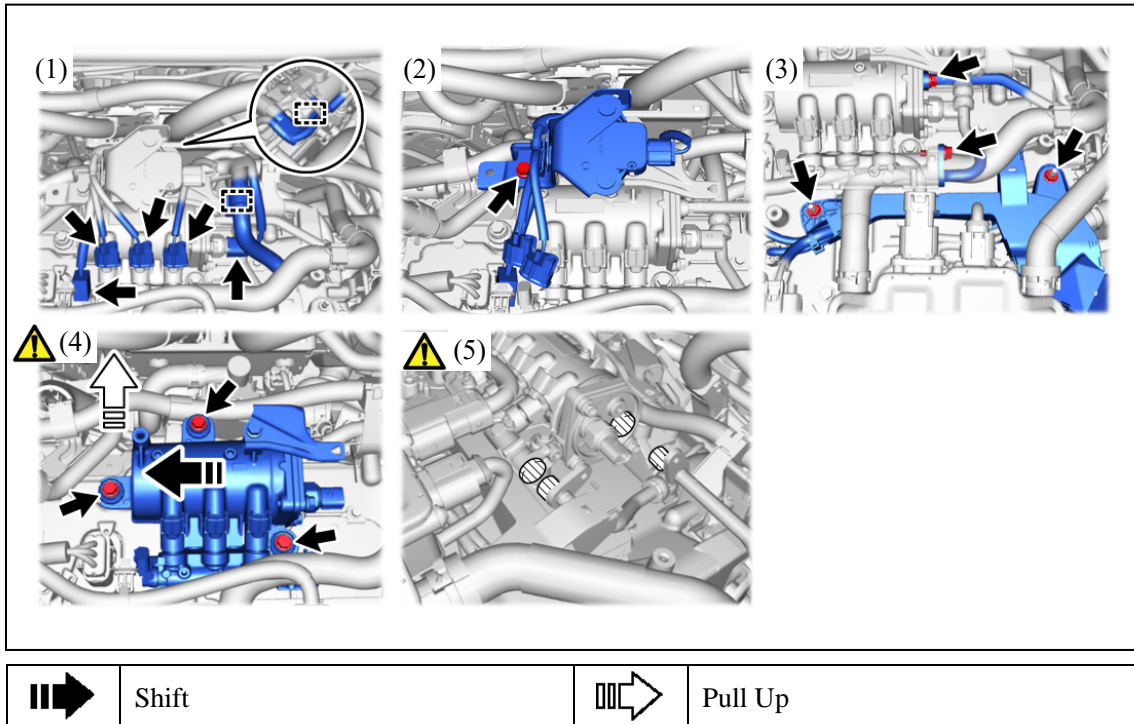

- (1) Disconnect the 5 connectors and detach the 2 clamps.
- (2) Remove the bolt and disconnect the No. 1 hydrogen detector bracket.
- (3) Remove the 2 nuts and 2 bolts.
- (4) Remove the 3 bolts and hydrogen supply pressure regulator assembly from the No. 1 hydrogen tube and No. 1 hydrogen supply tube sub-assembly.
- (5) Protect the openings of the No. 1 hydrogen tube, No. 1 hydrogen supply tube sub-assembly and hydrogen supply pressure regulator assembly with protective tape (non-residue type) to prevent the entry of foreign matter or water.

j. Remove the bolt and No. 1 hydrogen tube.

k. Cover the connection of the No. 1 hydrogen tube with plastic bags to prevent the foreign matter.

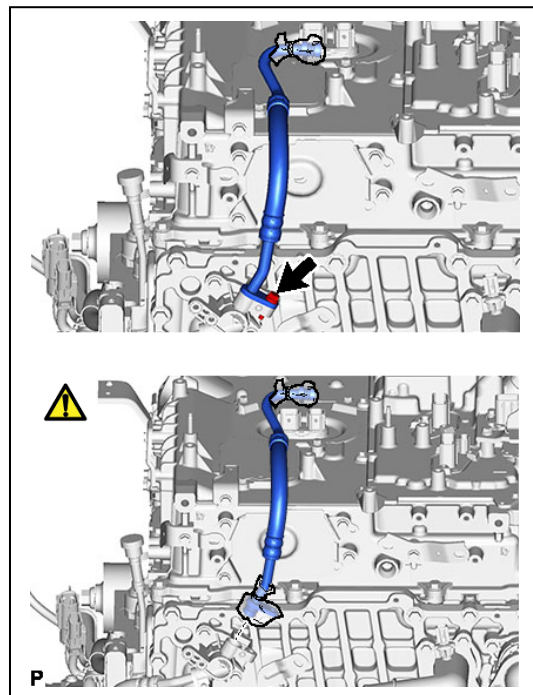

- l. Remove the 2 bolts and No. 2 hydrogen tube.
- m. Cover the connection of the No. 2 hydrogen tube with plastic bags to prevent the foreign matter.

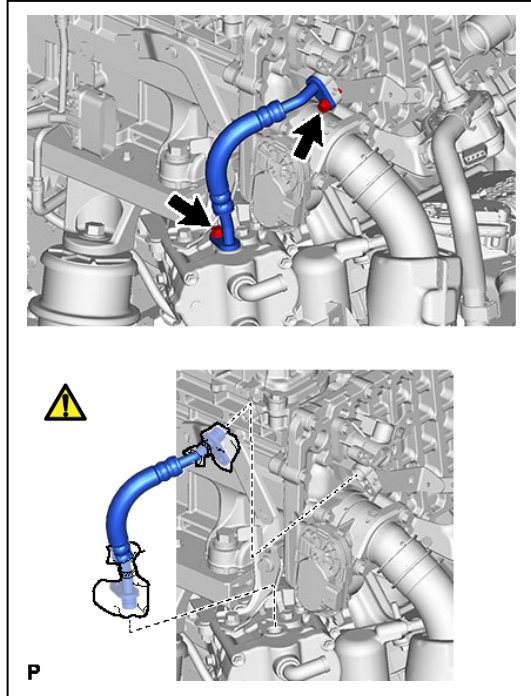

- n. Leave the vehicle as is for 18 hours.
- o. Measure the voltage according to the value(s) in the table below.

Standard Voltage:

Tester Connection	Specified Condition
Front side (positive terminal) - rear side (negative terminal)	Below 25 V

Notice

- If the voltage is not below 25 V, leave the vehicle until the voltage drops below 25 V.
- Do not perform disassembly work until the voltage drops below 25 V.

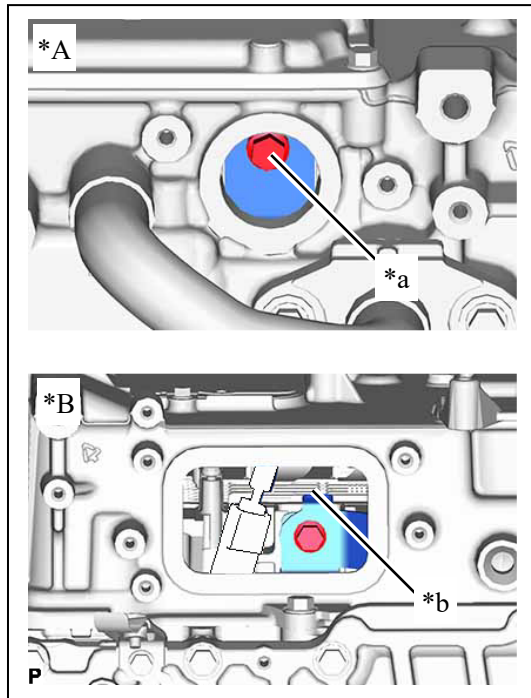

*A	Front Side
*B	Rear Side
*a	Positive Terminal
*b	Negative Terminal

- p. To prevent contamination by foreign matter or water droplets, cover the connecting portions of the FC air pressure regulator assembly (air sealing valve), FC stack hydrogen inlets and hydrogen recirculation pump assembly with protective tape.

- q. Perform removal of FC stack assembly. Follow the steps from "REMOVE FC AIR PRESSURE REGULATOR ASSEMBLY (AIR PRESSURE REGULATING

Removal of FC Stack Assembly

	<p>CAUTION:</p> <ul style="list-style-type: none">• Since high voltage accumulates within the FC stack assembly with FC converter, never perform the work of separating this part into the FC converter assembly and FC stack assembly without first discharging the electrical charge (electrical charge self-discharge), because doing so is dangerous.• Be sure to reduce the voltage within the FC stack assembly with FC converter to a level where work can be performed safely by performing electrical charge self-discharge. (This work is unnecessary if forced electrical charge discharge has been completed.)
---	--

1. REMOVE FC AIR PRESSURE REGULATOR ASSEMBLY (AIR SEALING VALVE) (WHEN FORCED ELECTRICAL CHARGE DISCHARGE COMPLETED)

a.

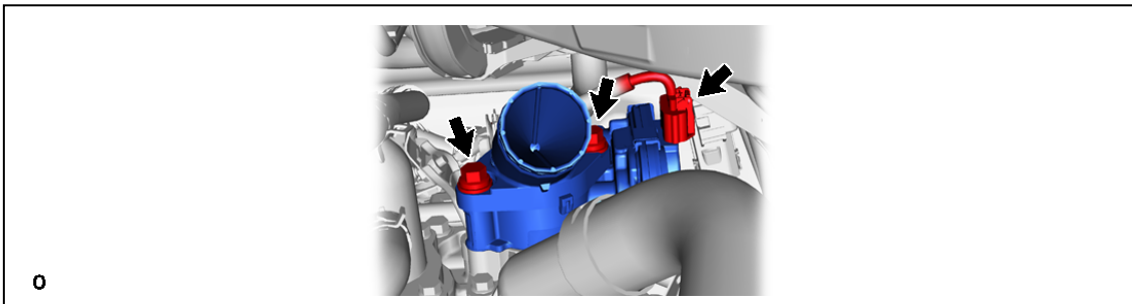

b.

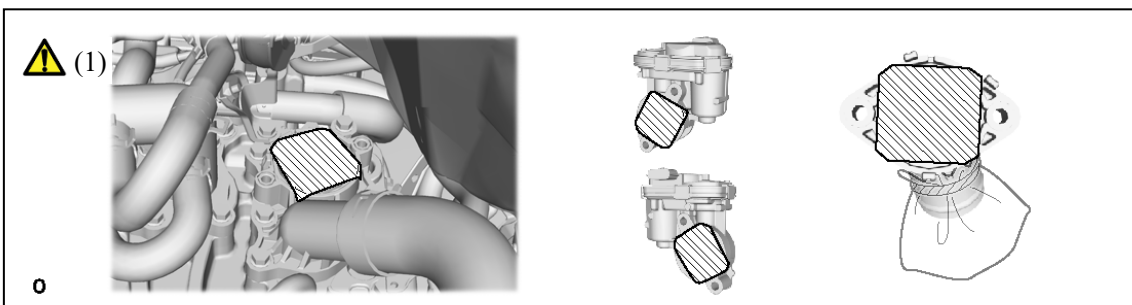

- (1) To prevent contamination by foreign matter or water droplets, cover the connecting portions of the FC air pressure regulator assembly (air sealing valve), FC stack air outlet pipe assembly and FC stack air outlet with protective tape.

2. REMOVE HYDROGEN SUPPLY PRESSURE REGULATOR ASSEMBLY (WHEN FORCED ELECTRICAL CHARGE DISCHARGE COMPLETED)

a.

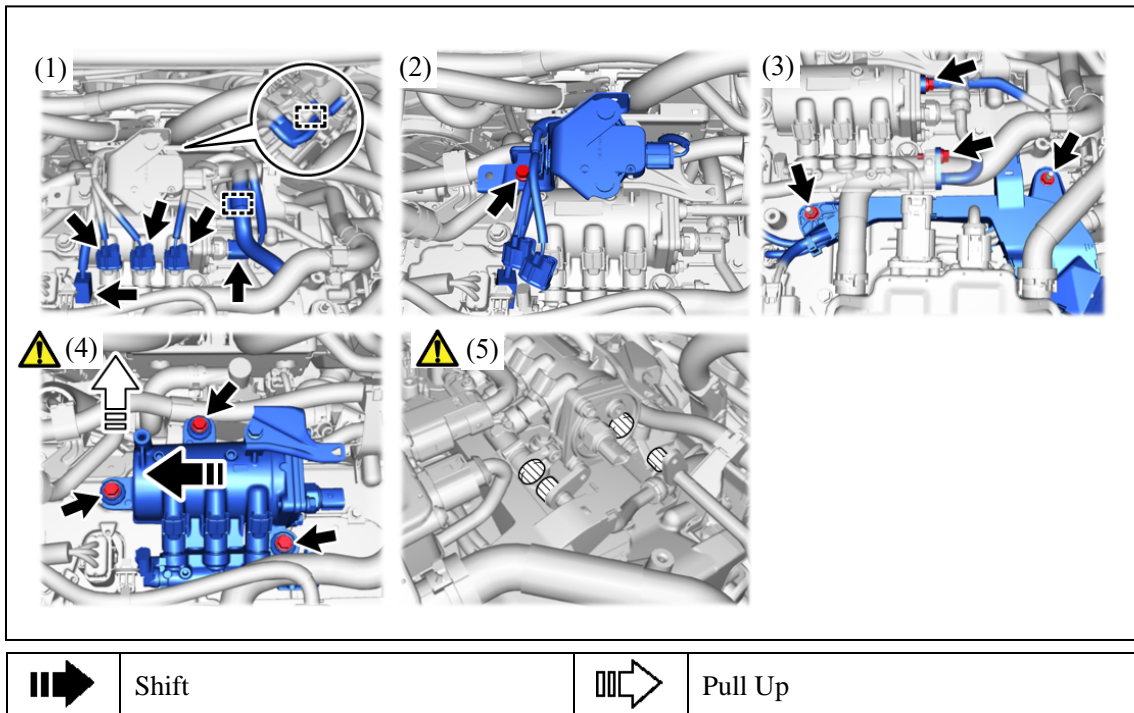

- (1) Disconnect the 5 connectors and detach the 2 clamps.
- (2) Remove the bolt and disconnect the No. 1 hydrogen detector bracket.
- (3) Remove the 2 nuts and 2 bolts.
- (4) Remove the 3 bolts and hydrogen supply pressure regulator assembly from the No. 1 hydrogen tube and No. 1 hydrogen supply tube sub-assembly.
- (5) Protect the openings of the No. 1 hydrogen tube, No. 1 hydrogen supply tube sub-assembly and hydrogen supply pressure regulator assembly with protective tape (non-residue type) to prevent the entry of foreign matter or water.

3. REMOVE NO. 1 HYDROGEN TUBE (WHEN FORCED ELECTRICAL CHARGE DISCHARGE COMPLETED)

a.

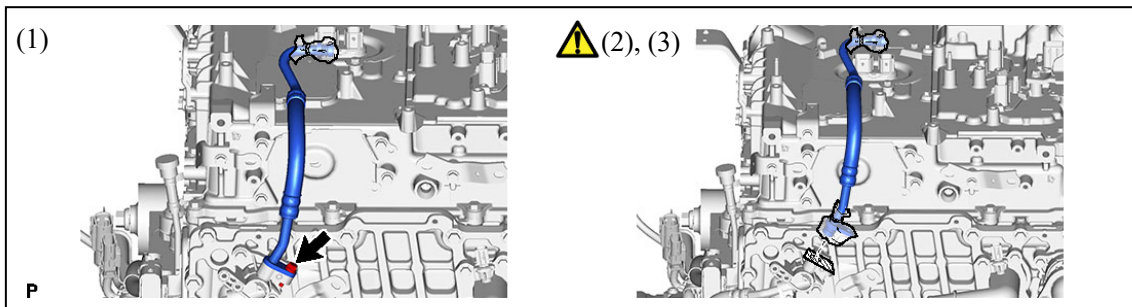

- (1) Remove the bolt and No. 1 hydrogen tube.
- (2) Cover the connection of the No. 1 hydrogen tube with plastic bags to prevent the foreign matter.
- (3) Protect the openings of the FC stack hydrogen inlet with protective tape (non-residue type) to prevent the entry of foreign matter or water.

4. REMOVE NO. 2 HYDROGEN TUBE (WHEN FORCED ELECTRICAL CHARGE DISCHARGE COMPLETED)

a.

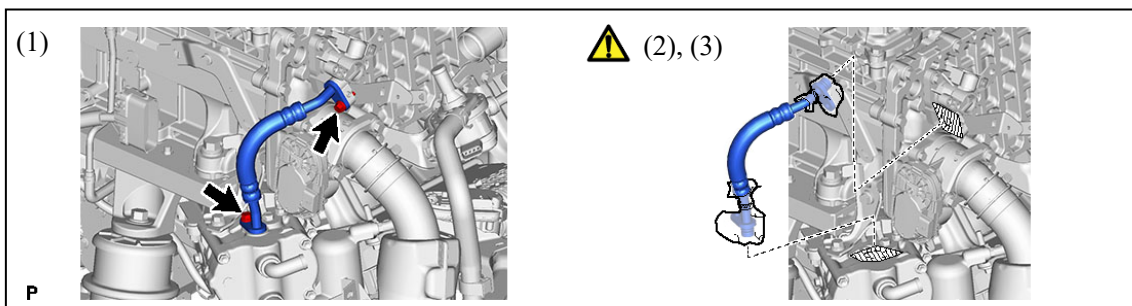

- (1) Remove the 2 bolts and No. 2 hydrogen tube.
- (2) Cover the connection of the No. 2 hydrogen tube with plastic bags to prevent the foreign matter.
- (3) Protect the openings of the FC stack hydrogen inlet and hydrogen recirculation pump assembly with protective tape (non-residue type) to prevent the entry of foreign matter or water.

5. REMOVE FC AIR PRESSURE REGULATOR ASSEMBLY (AIR PRESSURE REGULATING VALVE)

a.

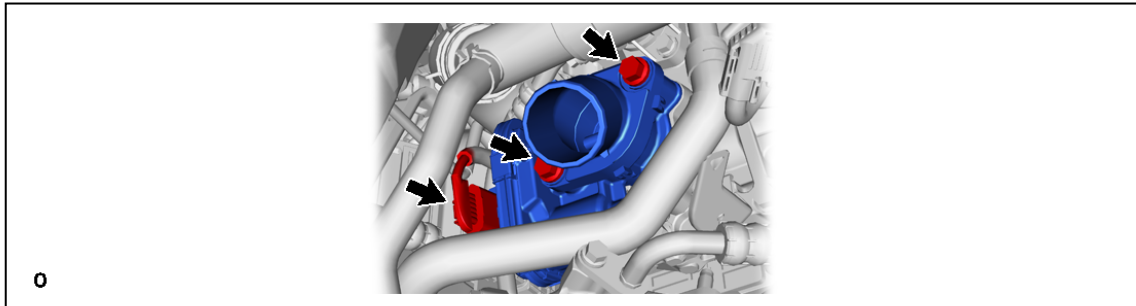

b.

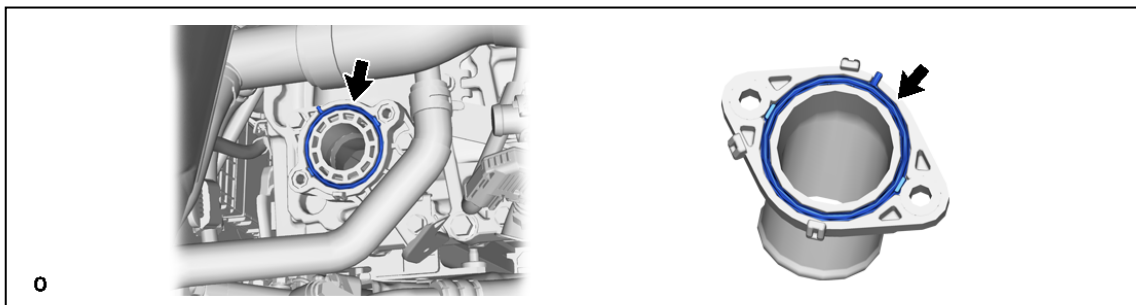

c.

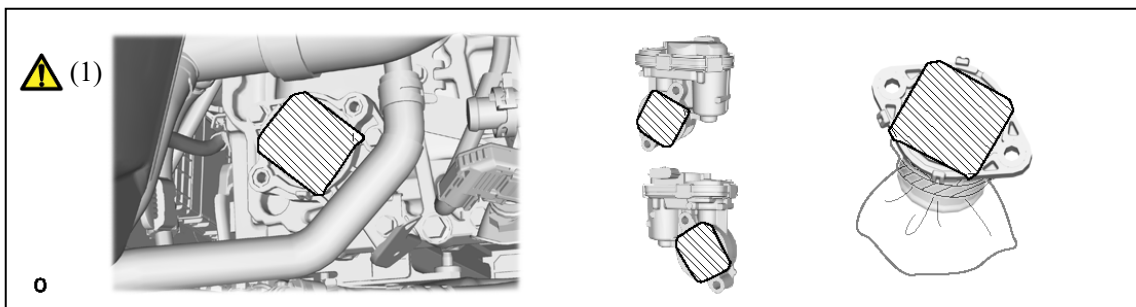

(1) To prevent contamination by foreign matter or water droplets, cover the connecting portions of the FC air pressure regulator assembly (air pressure regulating valve), FC stack air outlet pipe assembly and FC stack air outlet with protective tape.

6. REMOVE NO. 1 HYDROGEN SUPPLY TUBE SUB-ASSEMBLY

a.

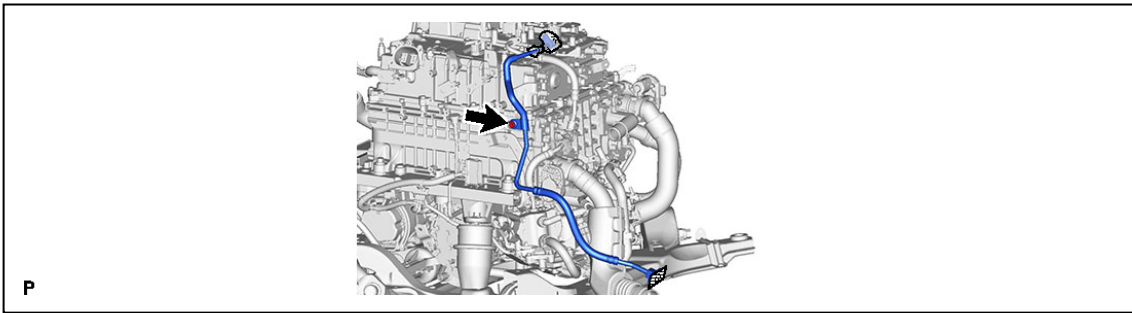

7. REMOVE FC CONVERTER WITH FC STACK ASSEMBLY

a.

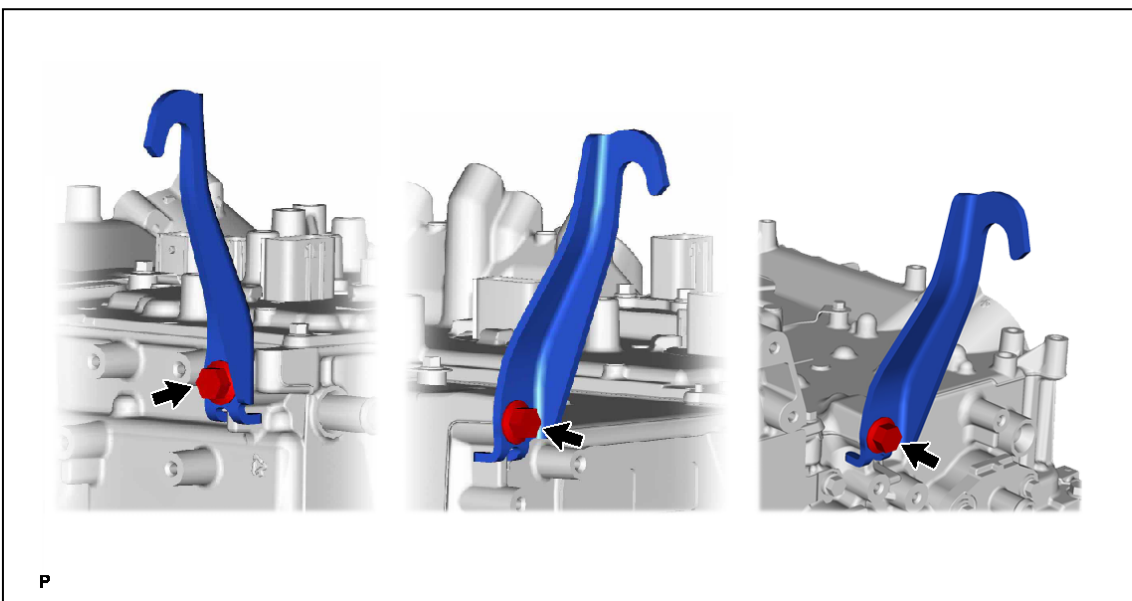

(1) Install the engine hanger with the 3 bolts as shown in the illustration.

Torque:

32 N*m (326 kgf*cm, 24 ft.*lbf)

Hint:

Engine Hanger	12282-28010
Bolt	91552-K1025

b.

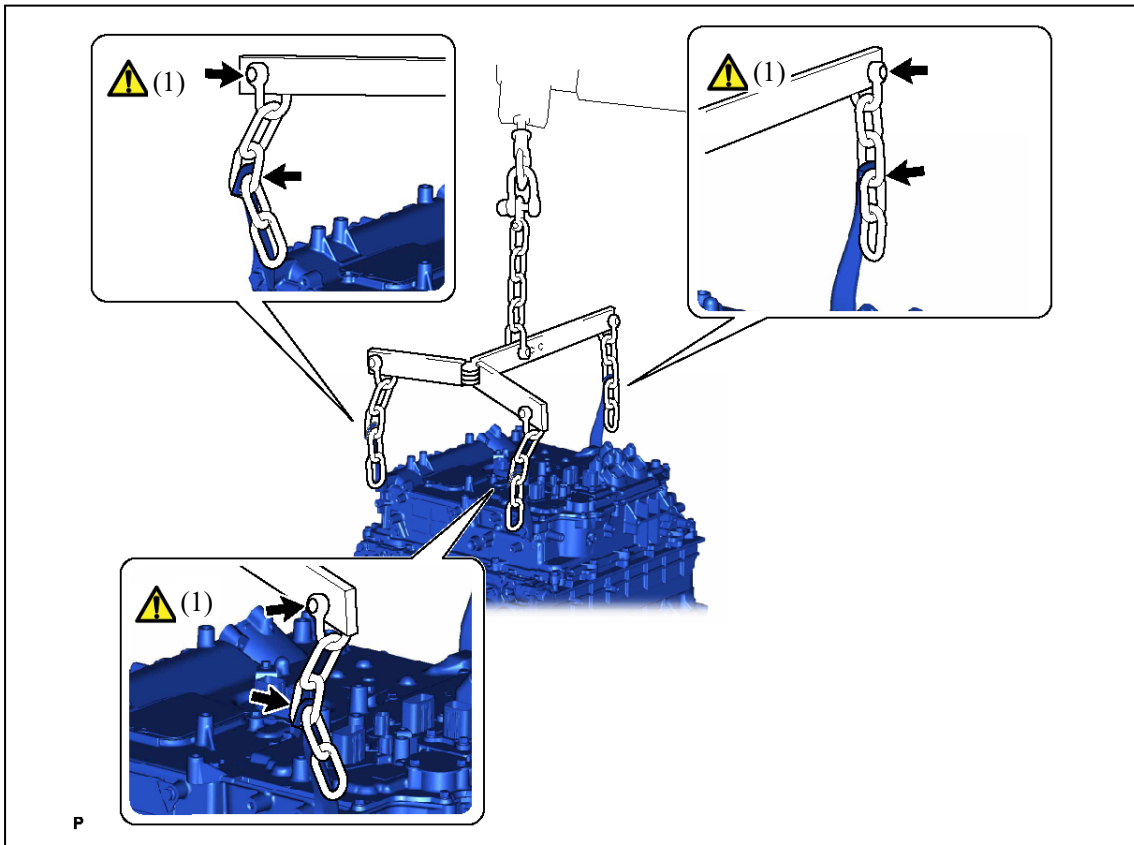

(1) Set up SST and the chain block as shown in the illustration.

SST

09940-78010

Notice

- Set up SST and the chain block so that the FC stack assembly with FC converter is level.
- Do not hoist the FC stack assembly with FC converter from points other than those shown in the illustration.

c.

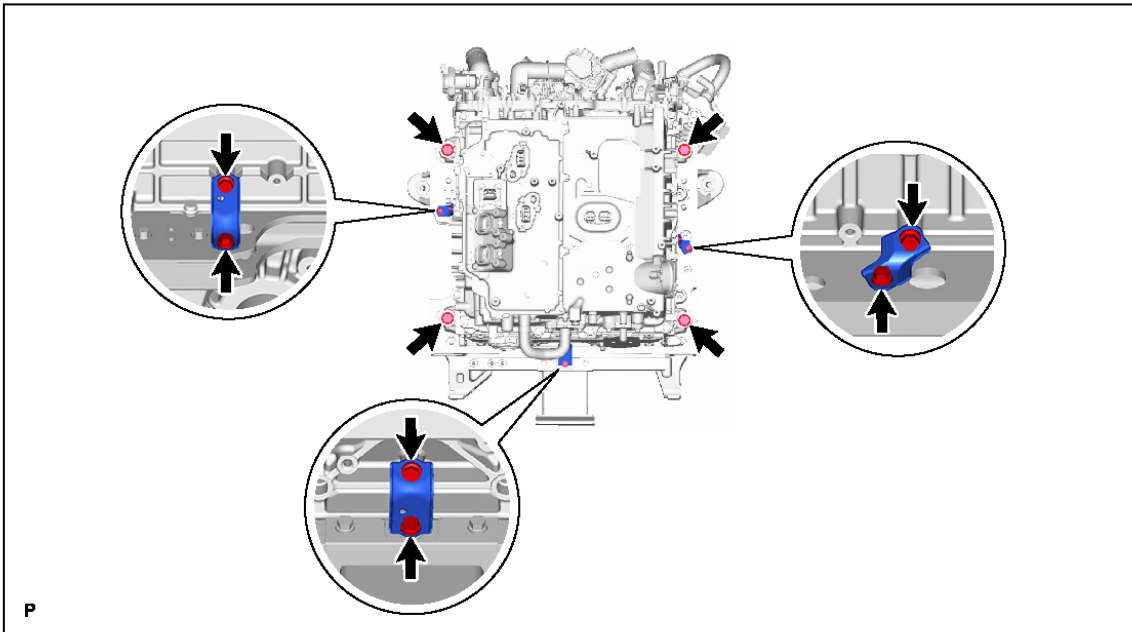

d.

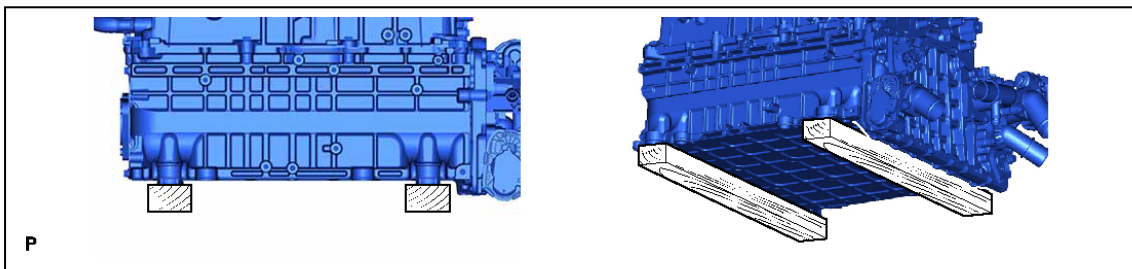

(1) Put wooden blocks on the work table and place the FC converter with FC stack assembly on them.

8. REMOVE FRONT FC CONVERTER SERVICE HOLE COVER (WHEN FORCED ELECTRICAL CHARGE DISCHARGE COMPLETED)

a.

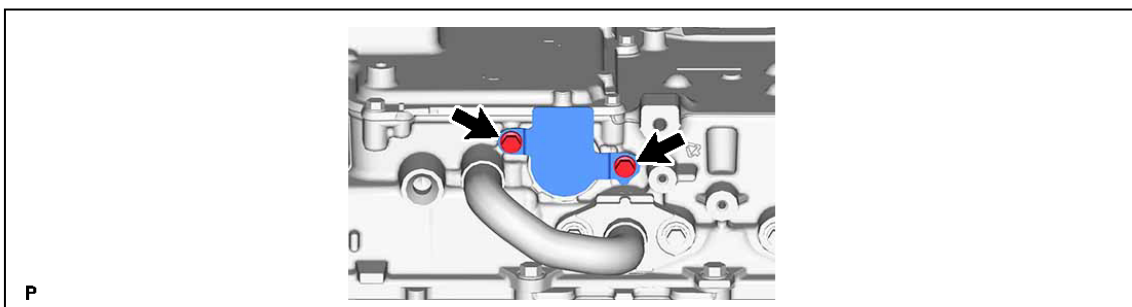

9. REMOVE NO. 1 FC STACK CASE PLUG (WHEN FORCED ELECTRICAL CHARGE DISCHARGE COMPLETED)

a.

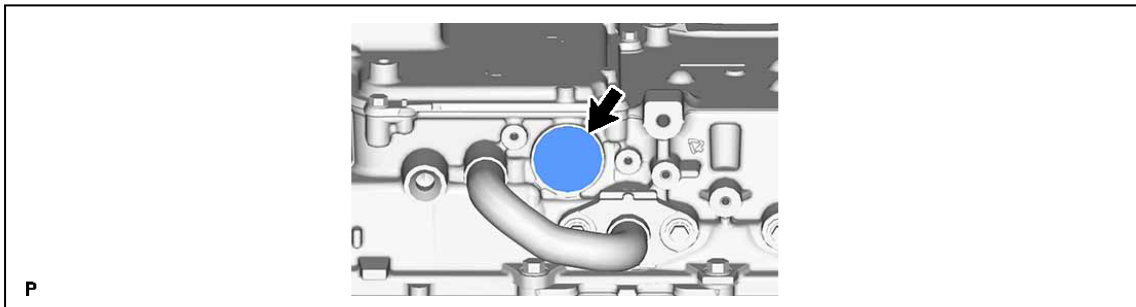

10. REMOVE FC CONVERTER VENT COVER (WHEN FORCED ELECTRICAL CHARGE DISCHARGE COMPLETED)

a.

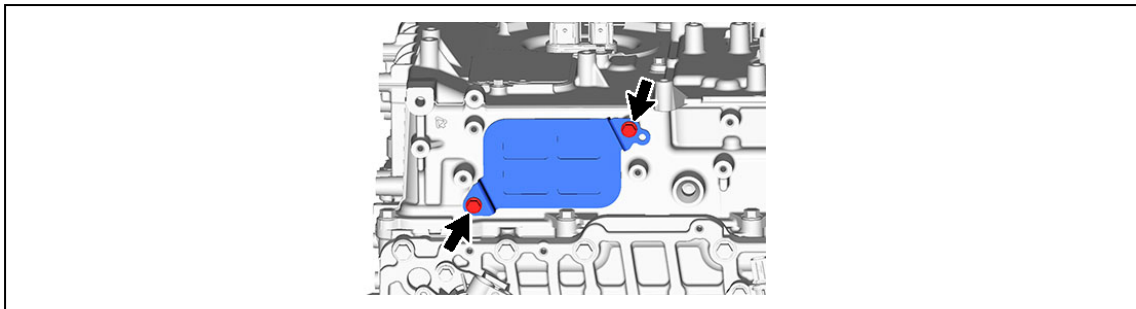

11. CLEAN FC CONVERTER WITH FC STACK ASSEMBLY

- a. Using a cloth, remove dirt and dust from the FC stack assembly with FC converter surface and around the bolts.

12. BOLT FALLING PREVENTION WORK (FRONT SIDE (POSITIVE TERMINAL))



NOTICE:

Be sure to perform this work, because it may not be possible to retrieve the bolt if it falls inside the FC stack assembly.

a.

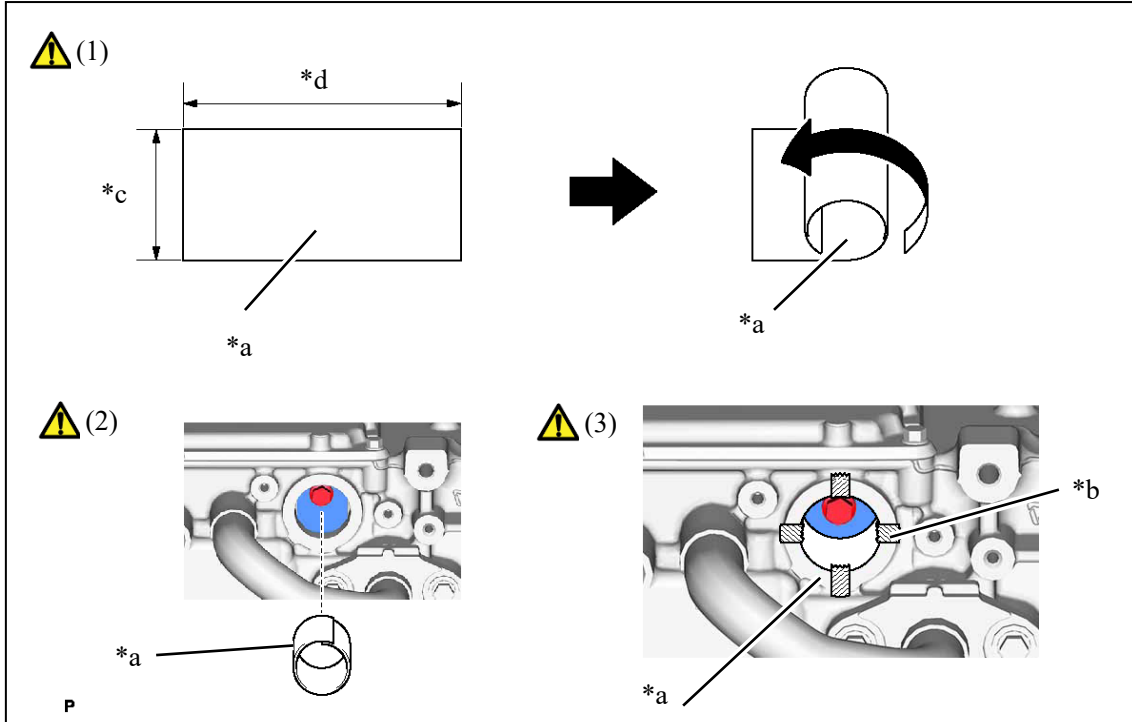

*a	Paper	*b	Tape
*c	Approximately 33 mm	*d	Approximately 110 mm

- (1) Prepare paper of the size shown in the illustration, and roll up the paper so that it overlaps.
- (2) Insert the rolled up paper into the FC converter assembly.
- (3) Firmly secure the inserted paper to the FC converter assembly with tape.

Notice:

Be sure to perform this work, because it may not be possible to retrieve the bolt if it falls inside the FC stack assembly.

13. REMOVE FC STACK ASSEMBLY

a.

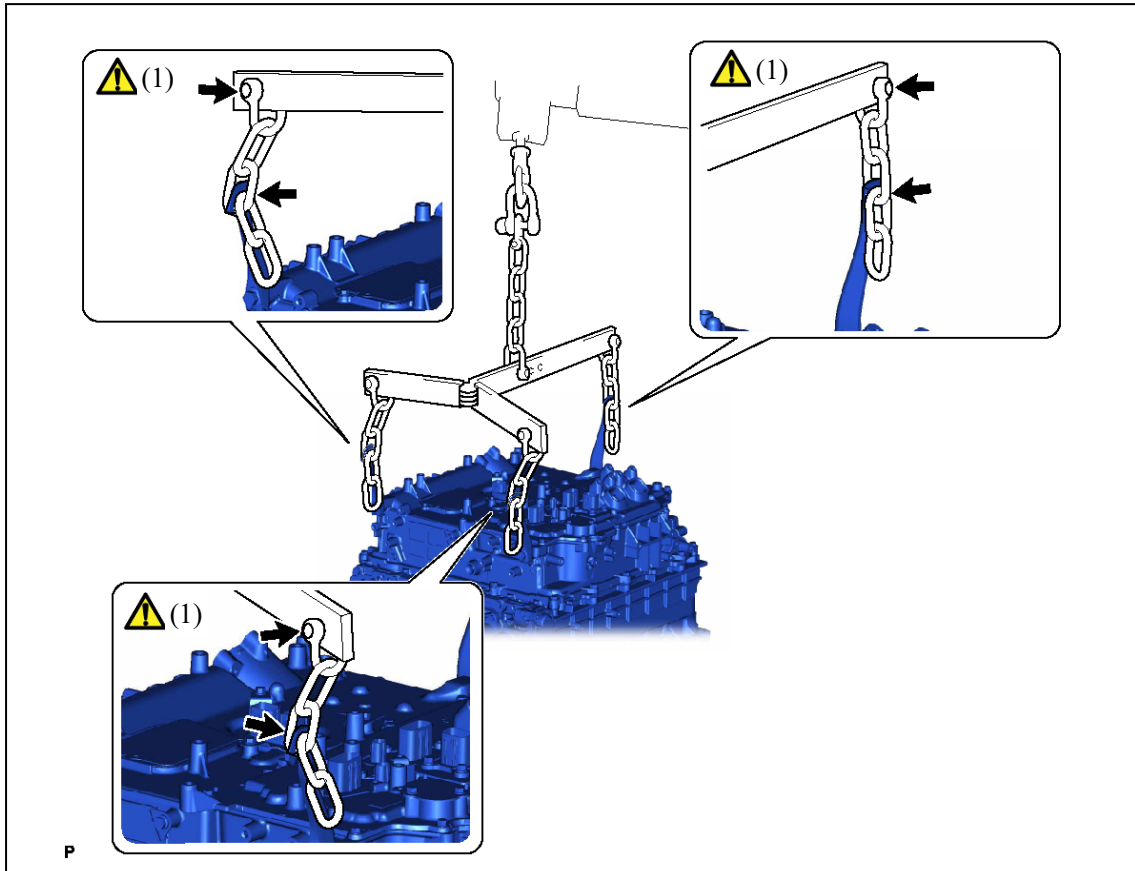

(1) Set up SST and the chain block as shown in the illustration.

SST

09940-78010

Notice

- Set up SST and the chain block so that the FC stack assembly with FC converter is level.
- Do not hoist the FC stack assembly with FC converter from points other than those shown in the illustration.

b.

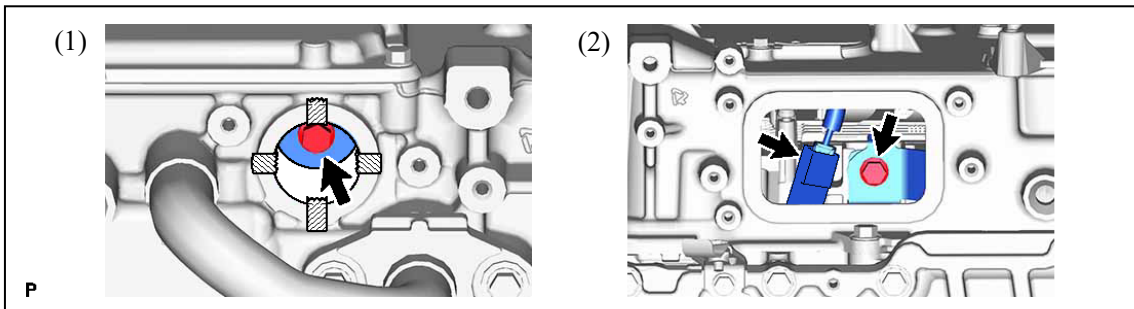

- (1) Remove the bolt.
- (2) Disconnect the connector and remove the bolt.

c.

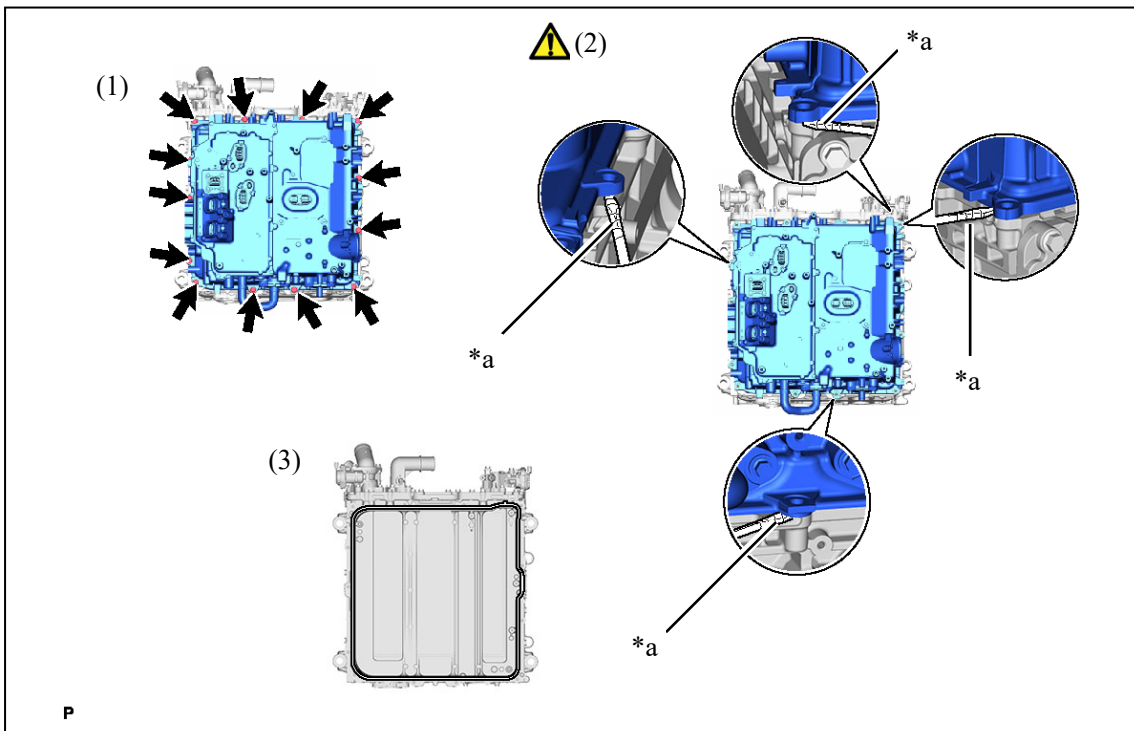

*a	Protective tape	-	-
----	-----------------	---	---

- (1) Remove the 13 bolts.
- (2) Using a screwdriver with its tip wrapped with protective tape, pry the points shown in the illustration and remove the FC stack assembly.

Notice:

- Remove the FC stack assembly carefully in a perpendicular orientation while making sure not to subject it to any impacts, because there is an FC stack voltage sensor on the FC stack assembly side, and the gap between the FC stack voltage sensor and FC converter assembly is small.
- Do not damage the contact surfaces of the FC stack assembly and FC converter assembly.

(3) Remove the upper FC stack case gasket from the FC stack assembly.

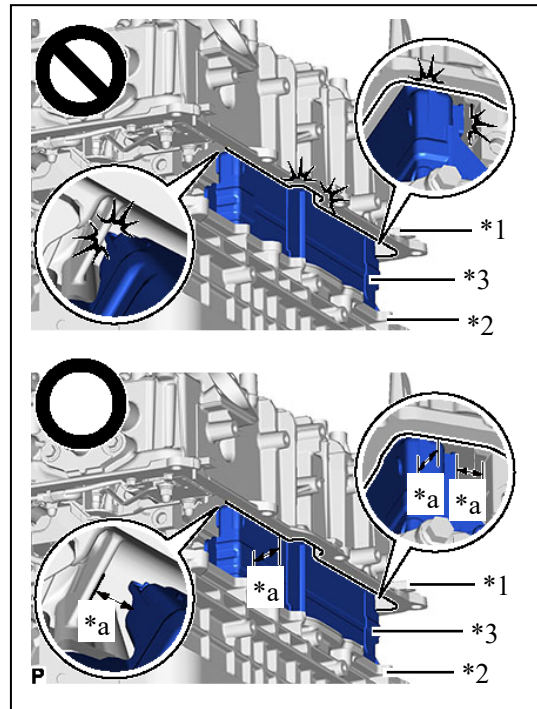

*1	FC Converter Assembly
*2	FC Stack Assembly
*3	FC Stack Voltage Sensor
*a	Gap

d.

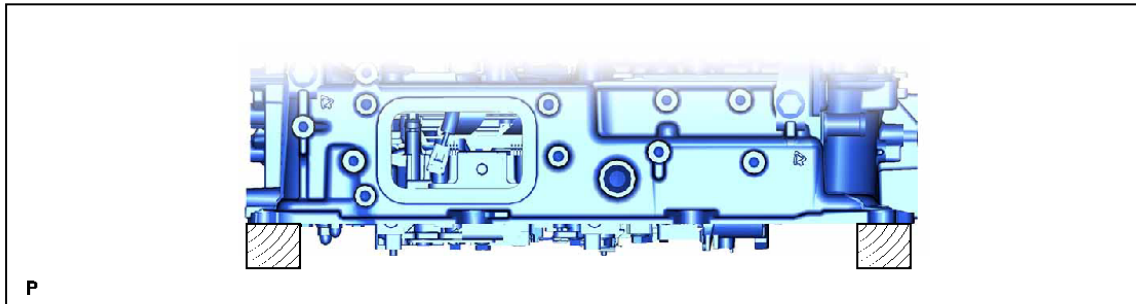

(1) Put wooden blocks on the work table and place the FC converter assembly on them.

Notice:

Use wooden blocks so that the protruding parts on the lower portion of the FC converter assembly does not make contact with the work table.